

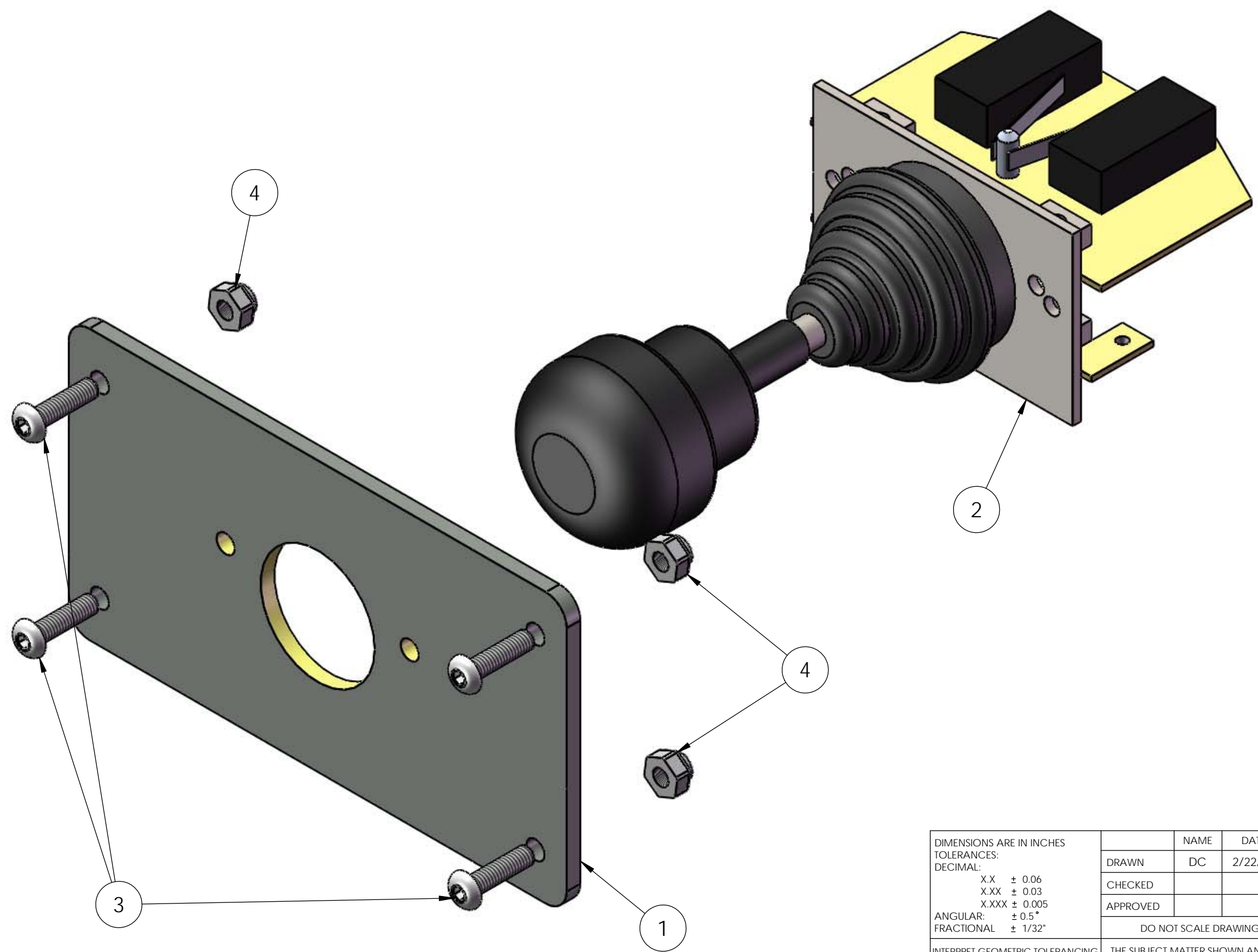

8 7 6 5 4 3 2 1

D
C
B
A

D
C
B
A



DIMENSIONS ARE IN INCHES		NAME	DATE	 TICO/TERMINAL SERVICE 66 CYPRESS RIDGE DR. RIDGELAND, SC 29936 (843) 717-2226	
TOLERANCES:		DRAWN	DC		2/22/08
DECIMAL:		CHECKED			
X.X ± 0.06 X.XX ± 0.03 X.XXX ± 0.005 ANGULAR: ± 0.5° FRACTIONAL ± 1/32"		APPROVED			
INTERPRET GEOMETRIC TOLERANCING PER: ASME 14.5M-1994		DO NOT SCALE DRAWING			TITLE:
MATERIAL		THE SUBJECT MATTER SHOWN AND DESCRIBED IN THIS DRAWING AND ANY OTHER INFORMATION ADVANCED IN CONNECTION THEREWITH, IS PROPRIETARY PROPERTY AND IS TO BE HELD IN STRICT CONFIDENCE BY YOU. ALL RIGHTS TO ANY INVENTIONS, DESIGNS, TRADE MARKS, TRADE NAMES AND COPYRIGHTS DISCLOSED ARE RESERVED TO TICO TERMINAL SERVICES, INC.			PANEL ASSEMBLY - 5TH WHEEL CONTROL
FINISH		SIZE	DWG. NO.	REV	
THICKNESS		B	91913		
		SCALE: 1:5	WEIGHT: 3.20	SHEET 1 OF 1	

8 7 6 5 4 3 2 1

