

DIMENSIONS ARE IN INCHES TOLERANCES: DECIMAL: .XX ± 0.04 .XXX ± 0.03 .XXXX ± 0.005 ANGULAR: ± 0.5° FRACTIONAL: ± 1/32"	NAME: SMB DATE: 5/26/15 CHECKED: APPROVED:	TICO/TERRINAL SERVICE 64 CYPRESS RIDGE DR. RIDGELAND, SC 29936 (843) 717-2226
INTERPRET GEOMETRIC TOLERANCING PER: ASME Y14.5M-1994 MATERIAL: FINISH: THICKNESS:	DO NOT SCALE DRAWING THE SUBJECT MATTER SHOWN AND DESCRIBED IN THIS DRAWING AND ANY OTHER INFORMATION ADVANCED IN CONNECTION THEREWITH IS PROPRIETARY PROPERTY AND IS TO BE HELD IN STRICT CONFIDENCE BY YOU. ALL RIGHTS TO ANY INVENTIONS, DESIGNS, TRADE MARKS, TRADE NAMES AND COPYRIGHTS DISCLOSED ARE RESERVED TO TICO/TERRINAL SERVICES, INC.	TITLE: AIR SYSTEM, 2-TANK SIZE DWG. NO.: D 72749-D1 SCALE: 1:50 WEIGHT:
		REV SHEET 1 OF 1

REV 72749-D1

REV.	DESCRIPTION	ECN	DATE	APPROVED
A	PRODUCTION RELEASE	04/20	11/8/10	HK
B	REMOVED 2" BLUE LINE	04/63	12/3/10	HK
C	REVISED AIR TANKS ROUTING	04/63	5/10/11	HK

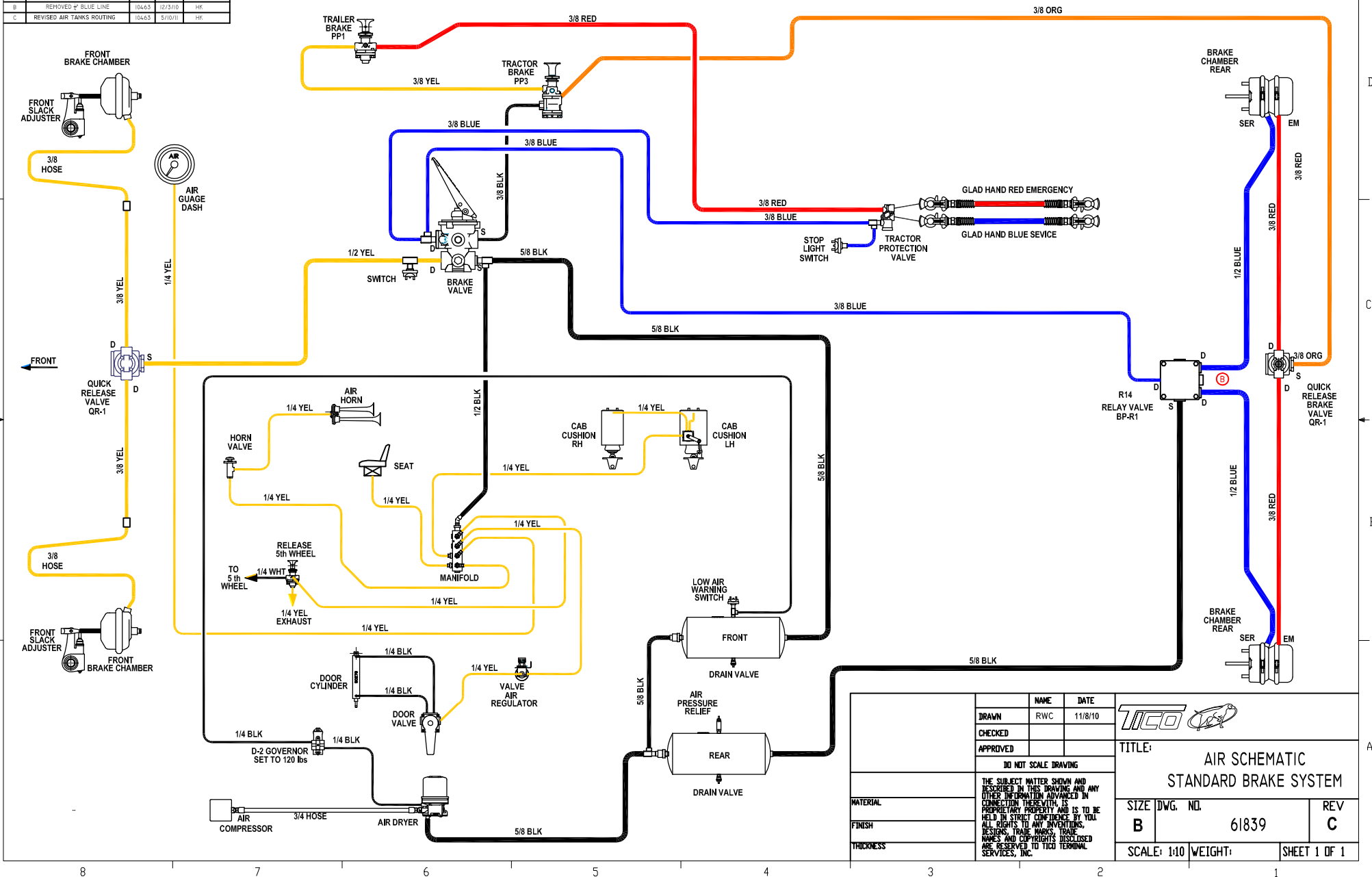

	NAME	DATE		TITLE: AIR SCHEMATIC STANDARD BRAKE SYSTEM	
DRAWN	RWC	11/8/10			
CHECKED					
APPROVED			DO NOT SCALE DRAWING		
MATERIAL	THE SUBJECT MATTER SHOWN AND DESCRIBED IN THIS DRAWING AND ANY OTHER INFORMATION ADVANCED IN CONNECTION THEREWITH IS PROPRIETARY PROPERTY AND IS TO BE HELD IN STRICT CONFIDENCE BY YOU. ALL RIGHTS TO ANY INVENTIONS, DESIGNS, TRADE MARKS, TRADE NAMES AND COPYRIGHTS DISCLOSED ARE RESERVED TO TICO TERMINAL SERVICES, INC.			SIZE DWG. NO. B 61839	REV C
FINISH				SCALE: 1:10	WEIGHT:
THICKNESS				SHEET 1 OF 1	