

**DPF, DRT, BRACKETS, & PIPES  
PAGE 3**

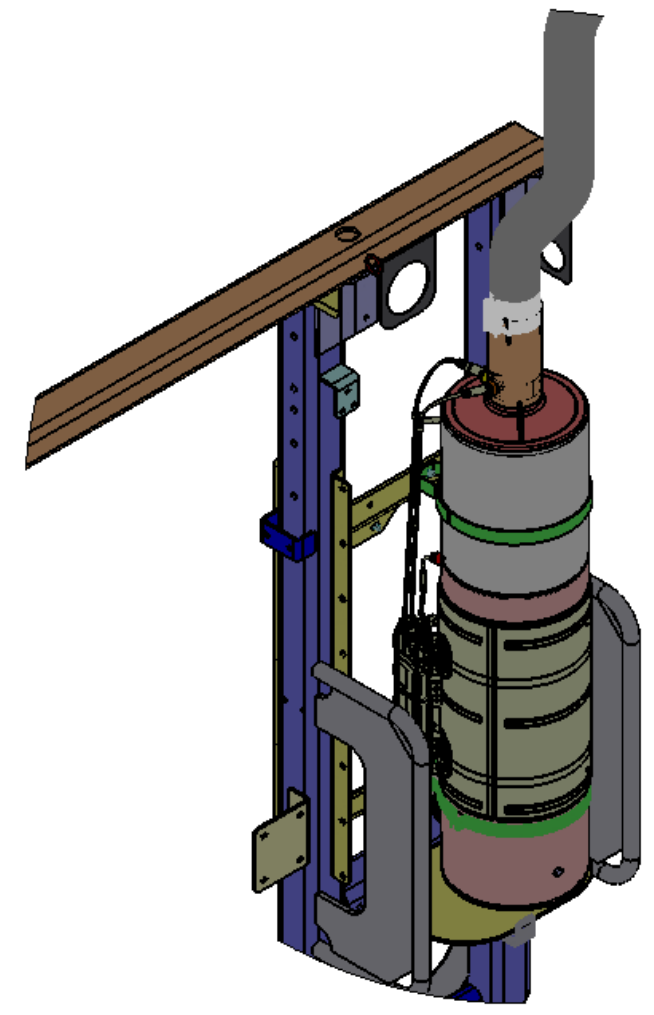

**SCR, EXHAUST STACK,  
& BRACKETS  
PAGE 2**

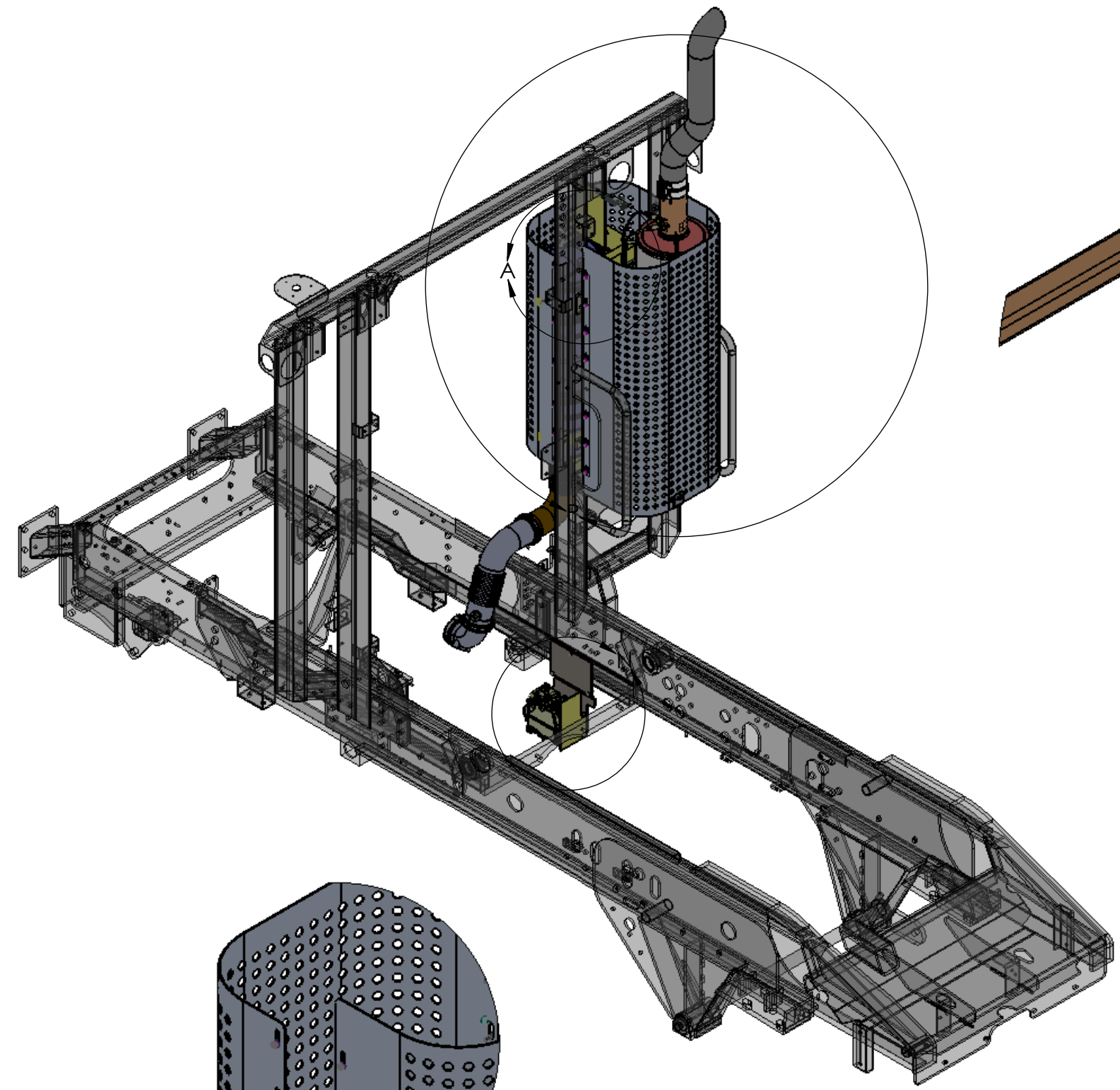

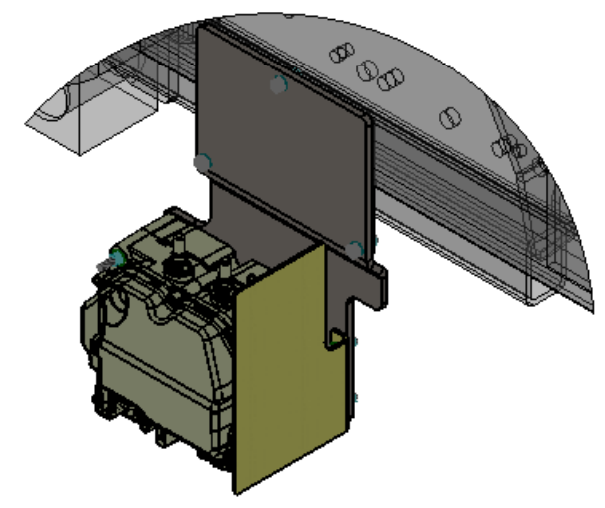

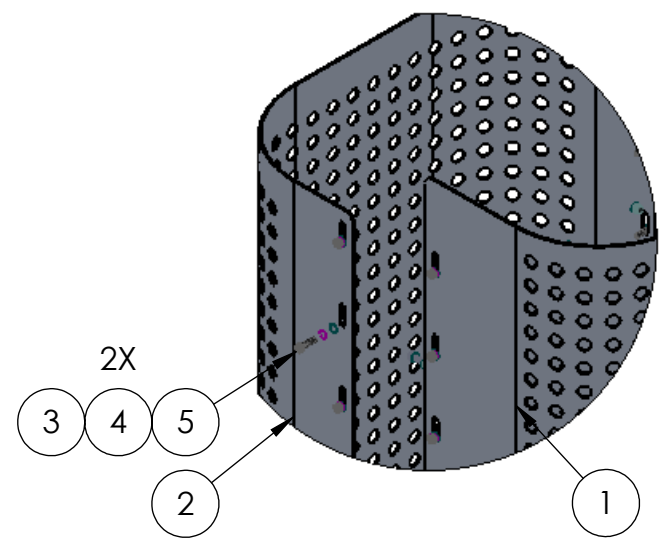
**SUPPLY MODULE & BRACKETS  
PAGE 2**

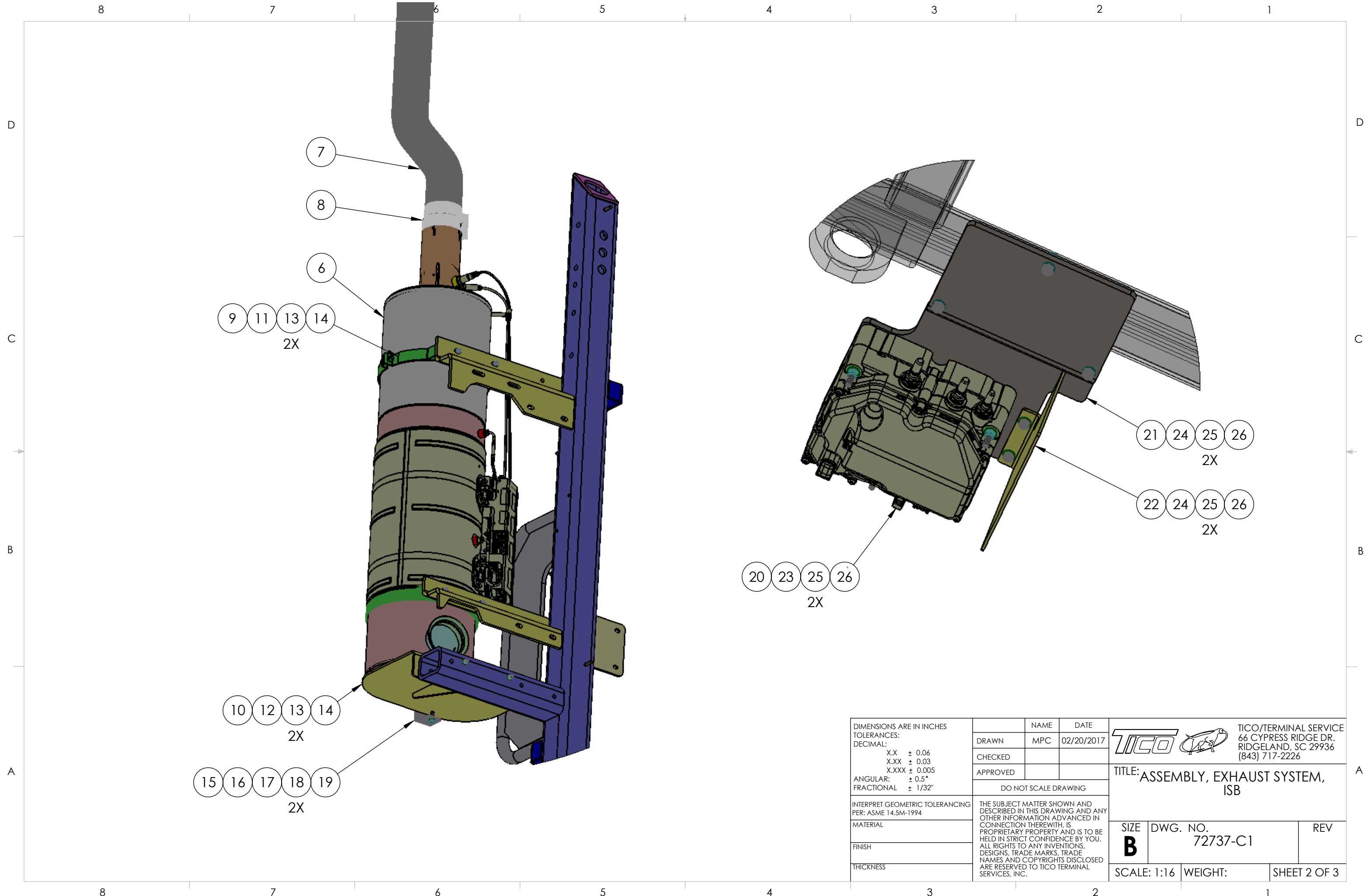

**HEAT SHIELDS  
(DETAIL A)**

DIMENSIONS ARE IN INCHES TOLERANCES: DECIMAL: X.X ± 0.06 X.XX ± 0.03 X.XXX ± 0.005 ANGULAR: ± 0.5° FRACTIONAL ± 1/32"	DRAWN MPC	NAME MPC	DATE 02/20/2017
	CHECKED		
	APPROVED		
DO NOT SCALE DRAWING			
INTERPRET GEOMETRIC TOLERANCING PER: ASME 14.5M-1994	THE SUBJECT MATTER SHOWN AND DESCRIBED IN THIS DRAWING AND ANY OTHER INFORMATION ADVANCED IN CONNECTION THEREWITH, IS PROPRIETARY PROPERTY AND IS TO BE HELD IN STRICT CONFIDENCE BY YOU. ALL RIGHTS TO ANY INVENTIONS, DESIGNS, TRADE MARKS, TRADE NAMES AND COPYRIGHTS DISCLOSED ARE RESERVED TO TICO TERMINAL SERVICES, INC.		
MATERIAL	TITLE: ASSEMBLY, EXHAUST SYSTEM, ISB	SIZE <b>B</b>	DWG. NO. 72737-C1
FINISH	SCALE: 1:16	WEIGHT:	REV SHEET 1 OF 3
THICKNESS			



DIMENSIONS ARE IN INCHES TOLERANCES: DECIMAL: X.X ± 0.06 X.XX ± 0.03 X.XXX ± 0.005 ANGULAR: ± 0.5° FRACTIONAL ± 1/32"	NAME	DATE	 TICO/TERMINAL SERVICE 66 CYPRESS RIDGE DR. RIDGELAND, SC 29936 (843) 717-2226	
	DRAWN	MPC		02/20/2017
	CHECKED			
	APPROVED			
INTERPRET GEOMETRIC TOLERANCING PER: ASME 14.5M-1994	DO NOT SCALE DRAWING		TITLE: ASSEMBLY, EXHAUST SYSTEM, ISB	
MATERIAL	THE SUBJECT MATTER SHOWN AND DESCRIBED IN THIS DRAWING AND ANY OTHER INFORMATION ADVANCED IN CONNECTION THEREWITH, IS PROPRIETARY PROPERTY AND IS TO BE HELD IN STRICT CONFIDENCE BY YOU. ALL RIGHTS TO ANY INVENTIONS, DESIGNS, TRADE MARKS, TRADE NAMES AND COPYRIGHTS DISCLOSED ARE RESERVED TO TICO TERMINAL SERVICES, INC.		SIZE <b>B</b> DWG. NO. 72737-C1 REV	
FINISH			SCALE: 1:16	
THICKNESS			WEIGHT:	
			SHEET 2 OF 3	

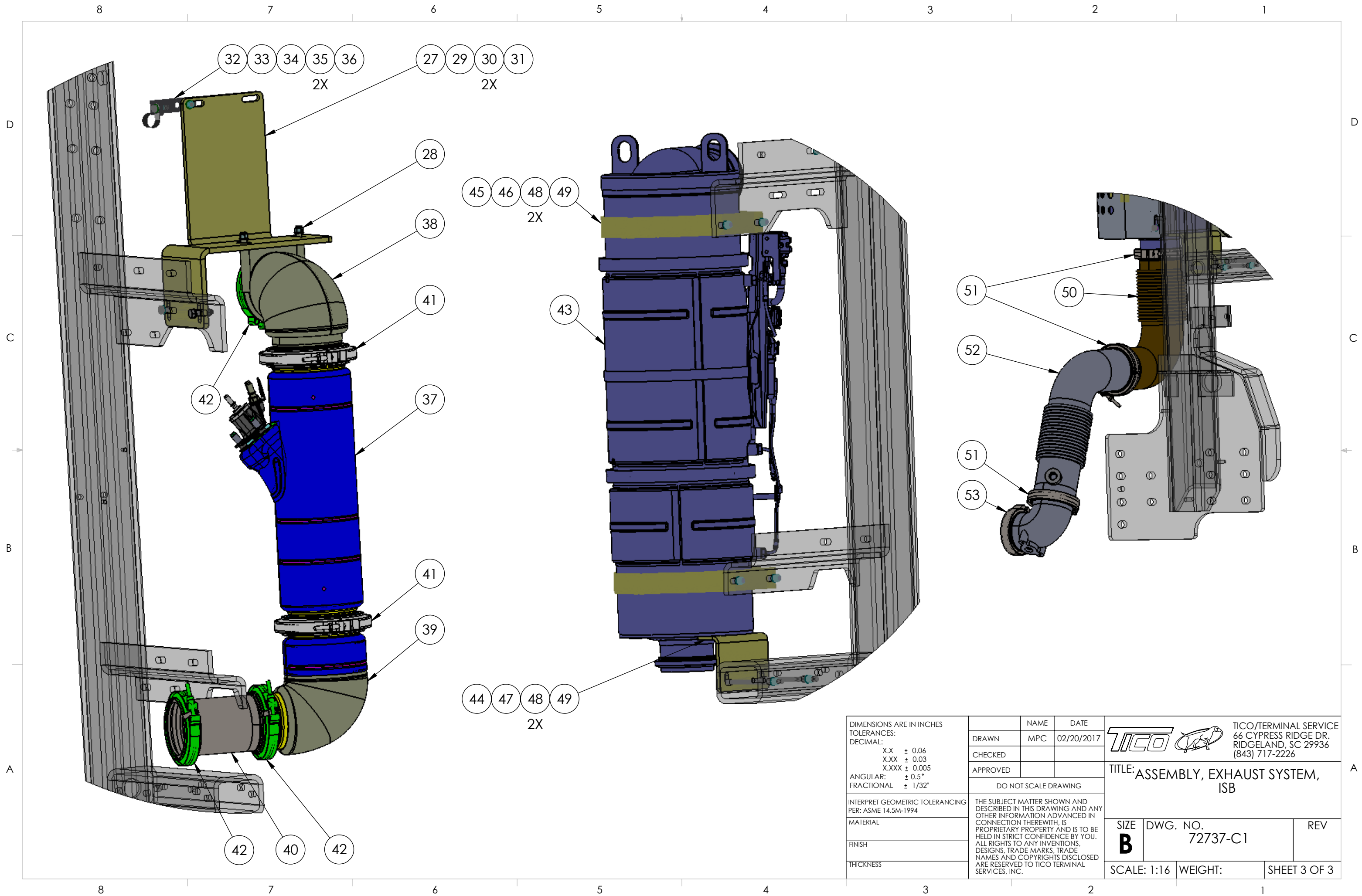

**TICO** TICO/TERMINAL SERVICE  
 66 CYPRESS RIDGE DR.  
 RIDGELAND, SC 29936  
 (843) 717-2226

TITLE: ASSEMBLY, EXHAUST SYSTEM, ISB

SIZE **B** DWG. NO. 72737-C1

SCALE: 1:16 WEIGHT: SHEET 3 OF 3



