

DIMENSIONS ARE IN INCHES		NAME		DATE	TICO MANUFACTURING 66 CYPRUS RIDGE DR. ROSELAND, NC 28088 TICORACTORS.COM
DECIMAL	XXX.XX	DRAWN	ACW	04/22/2020	
ANGULAR	XX.X	CHECKED			<b>TICO</b> TITLE: DASH ASSY-KPH SPEEDO-12V- PUSH BUTTON-CABLE SIZE DWG. NO. REV <b>D</b> 72707-A1 1 OF 1 SCALE: 1:4 WEIGHT: 18.28 SHEET 1 OF 1
FRACTIONAL	XX/XX	APPROVED			
DO NOT SCALE DRAWING		THE SUBJECT MATTER SHOWN AND DESCRIBED IN THIS DRAWING AND ANY OTHER INFORMATION CONTAINED HEREIN IS THE PROPERTY OF TICO MANUFACTURING, INC. AND IS TO BE KEPT IN CONFIDENCE BY ALL PERSONS TO WHOM IT IS FURNISHED. NO PARTS OR COMPONENTS THEREOF ARE TO BE REPRODUCED OR USED IN ANY MANNER WITHOUT THE WRITTEN PERMISSION OF TICO MANUFACTURING, INC.			

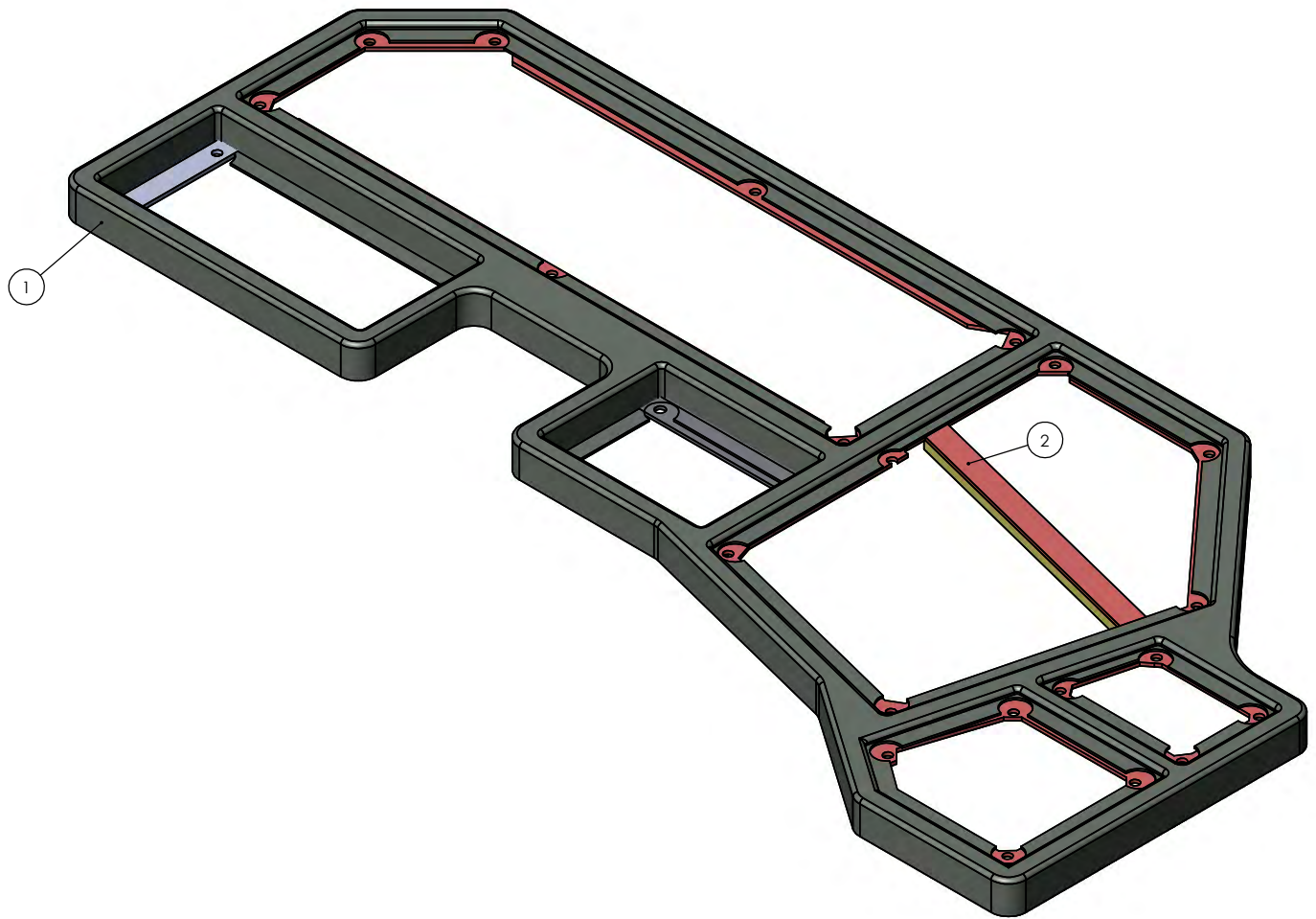



DIMENSIONS ARE IN INCHES		NAME	DATE	TICO MANUFACTURING	
TOLERANCES:		DRAWN	ADW	06/22/2020	44 CYPRESS RIDGE DR.
DECIMAL	.XX	CHECKED			ROCKLAND, NC 29154
	.XXX	APPROVED			TICORACTORS.COM
	.XXX & UP				
	.XXX & UP				
ANGULAR	± .1°	DO NOT SCALE DRAWING			
FRACTIONAL	± .005	THE SUBJECT MATTER SHOWN AND			
		DESCRIBED IN THIS DRAWING AND ANY			
		OTHER REFERENCE IS INDICATED IN			
		CONNECTIONS BETWEEN PARTS TO BE			
		ASSEMBLED SHALL BE AS SHOWN UNLESS			
		OTHERWISE SPECIFIED BY THE			
		DRAWING. DIMENSIONS SHOWN			
		UNLESS OTHERWISE SPECIFIED			
		ARE TO BE IN INCHES UNLESS			
		OTHERWISE SPECIFIED			
		BY THE DRAWING			
		DATE			
		SCALE			
		WEIGHT			
		SHEET			

**TICO**  
 TITLE: DASH COVER ASSEMBLY ISB  
 10  
 SIZE DWG. NO. 91646-A1  
 SCALE: 1:4 | WEIGHT: 7.29 | SHEET 1 OF 1

91646-A1  
 D



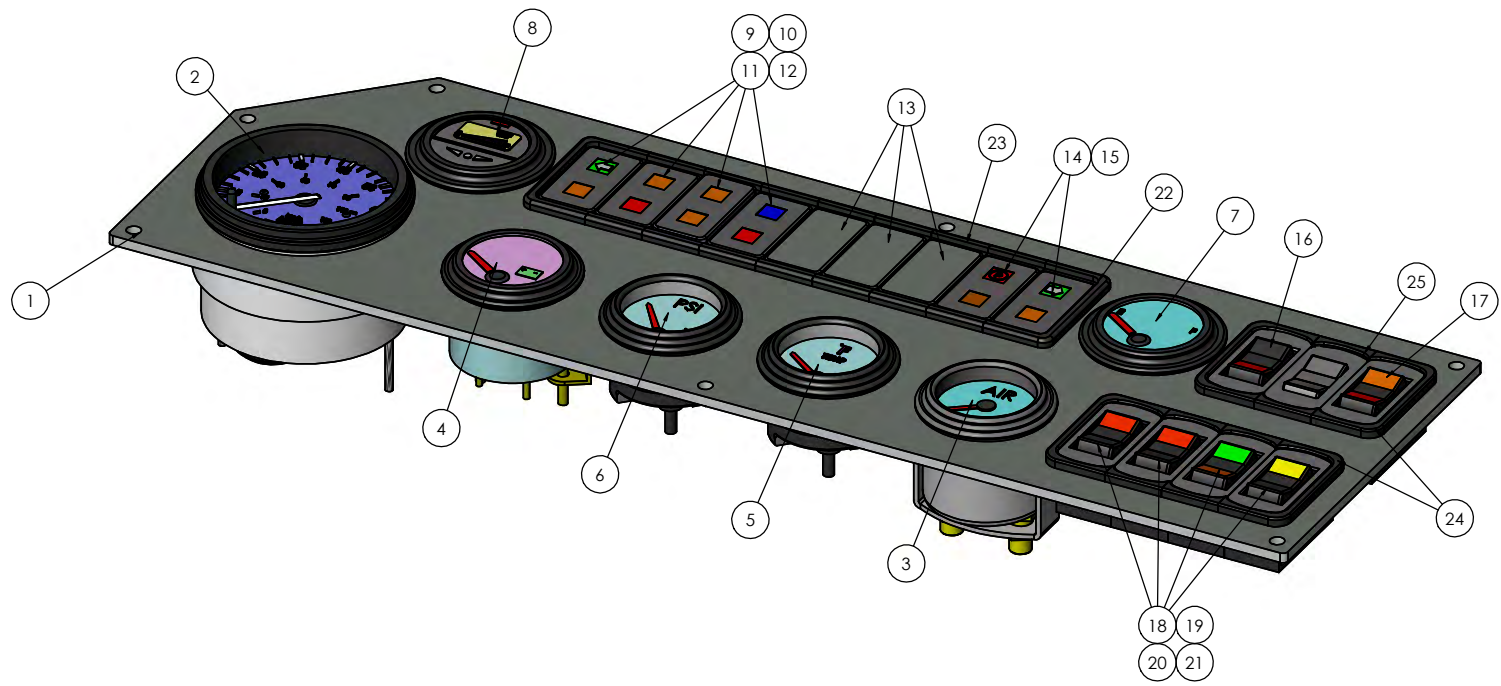

DIMENSIONS ARE IN INCHES		NAME	DATE	TICO MANUFACTURING
TOLERANCES:		DRAWN	ADW	04/23/2020
DECIMAL	.0005	CHECKED		66 CYPRESS ROUGE DR.
FRACTIONAL	0.001	APPROVED		ROCKLAND, NC 28574
ANGULAR	0.1°			TICORACTORS.COM
FUNCTIONAL	0.1°	DO NOT SCALE DRAWING		
INSURE GEOMETRIC TOLERANCING PER ASME Y14.5M-1994				
THE SUBJECT MATTER SHOWN AND DESCRIBED IN THIS DRAWING AND ANY OTHER INFORMATION CONTAINED HEREIN IS THE PROPERTY OF TICO MANUFACTURING, INC. ALL RIGHTS TO ANY PATENTS, TRADEMARKS, AND COPYRIGHTS NOTICED ARE RESERVED BY TICO MANUFACTURING, INC.				
TITLE:	PANEL ASSY SPEEDO GAUGES INDICATORS WIPERS			
SIZE	DWG. NO.	REV		
D	91799-A1			
SCALE: 1:2	WEIGHT: 3.26	SHEET 1 OF 1		

D 91799-A1



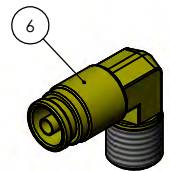
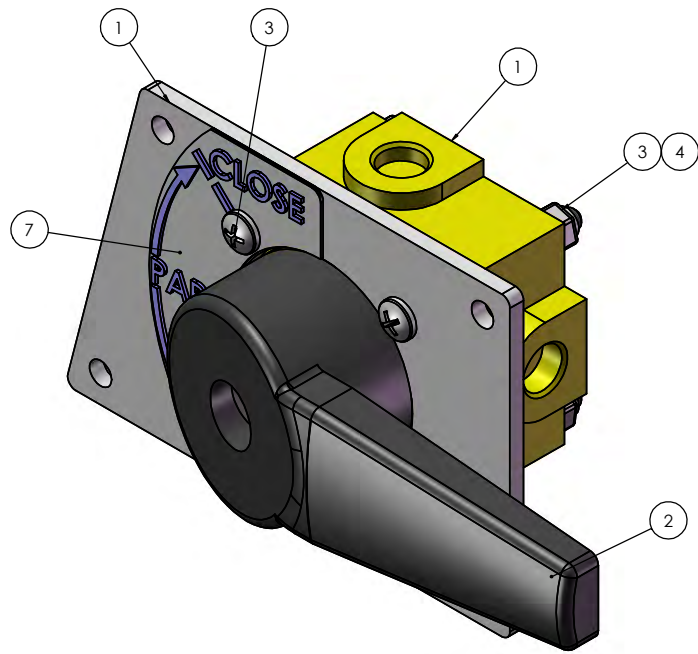

DIMENSIONS ARE IN INCHES		NAME	DATE	TICO MANUFACTURING
TOLERANCES:	DECIMAL	DRAWN	ADW	06/22/2020
	.005	CHECKED		44 CYPRESS RIDGE DR.
	.010	APPROVED		ROCKLAND, SC 29554
	.015	DO NOT SCALE DRAWING		TICORACTORS.COM
	.030			
ANGULAR:	± 1.0°	THE SUBJECT MATTER SHOWN AND DESCRIBED IN THIS DRAWING AND ANY OTHER INFORMATION CONTAINED IN CONNECTION HEREWITH IS TO BE CONSIDERED TO BE THE PROPERTY OF TICO MANUFACTURING AND IS NOT TO BE REPRODUCED OR TRANSMITTED IN ANY FORM OR BY ANY MEANS, ELECTRONIC OR MECHANICAL, INCLUDING PHOTOCOPYING, RECORDING, OR BY ANY INFORMATION STORAGE AND RETRIEVAL SYSTEM, WITHOUT PERMISSION IN WRITING FROM TICO MANUFACTURING, INC.		
FUNCTIONAL:	± .002	TITLE: ASSEMBLY, PANEL DASH DOOR VALVE		
INSURE GEOMETRIC TOLERANCING PER ASME Y14.5M		SIZE	DWG. NO.	REV
		D	20183-A1	
		SCALE: 1:1	WEIGHT:	SHEET 1 OF 1

D 20183-A1



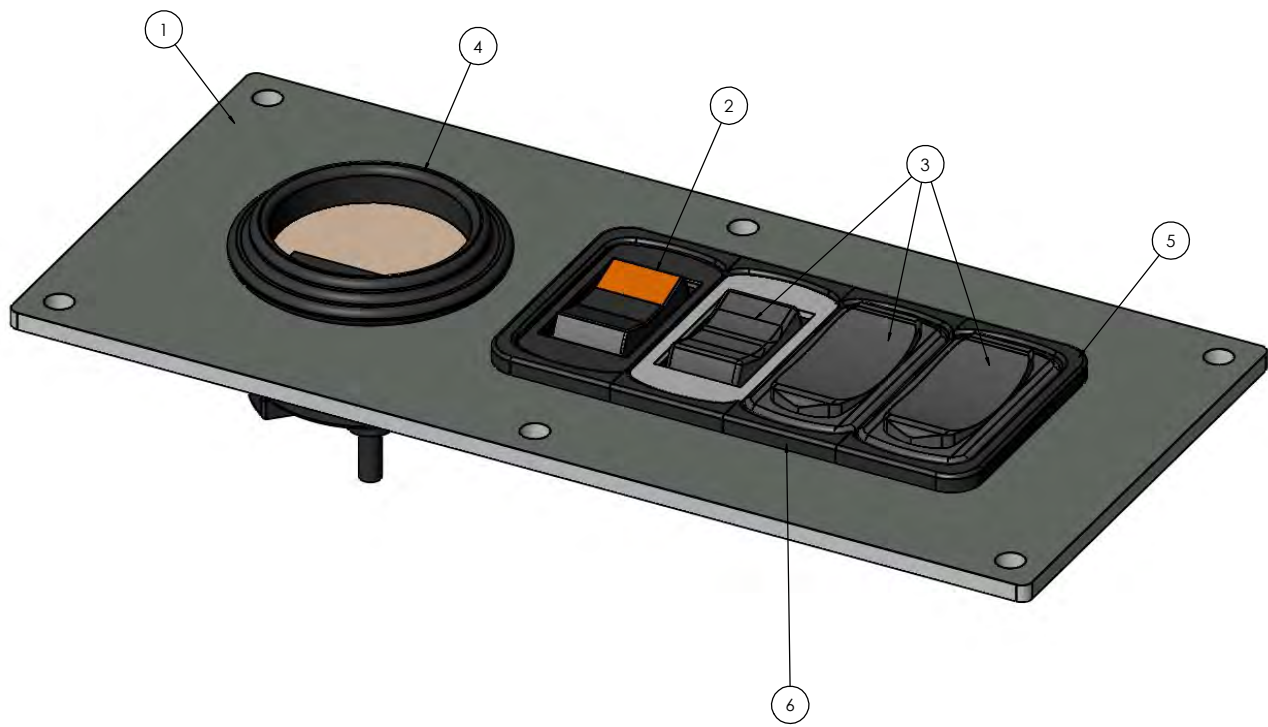

DIMENSIONS ARE IN INCHES		NAME	DATE	TICO MANUFACTURING
TOLERANCES:	DECIMAL	DRAWN	ADW	6/16/23/2020
	.0001	CHECKED		66 CYPRESS RIDGE DR.
	.0002	APPROVED		ROCKLAND, SC 29574
	.0005			TICORACTORS.COM
	.0010			
ANGULAR:	± 1.0°	DO NOT SCALE DRAWING		
FRACTIONAL:	± .005	THE SUBJECT MATTER SHOWN AND		
		DESCRIBED IN THIS DRAWING AND ANY		
		OTHER REFERENCE IS INDICATED IN		
		CONNECTIONS ARE TO BE		
		RECORDED IN THE OFFICE OF THE		
		ENGINEER. THIS DRAWING IS TO BE		
		USED ONLY FOR THE PURPOSES		
		STATED. ANY OTHER USES ARE		
		UNAUTHORIZED. TICO MANUFACTURING		
		AND CONTRACTORS DESIGN		
		ARE NOT TO BE USED FOR ANY OTHER		
		PURPOSES WITHOUT THE WRITTEN		
		CONSENT OF TICO MANUFACTURING		

**TICO**  
 TITLE: ASSY PANEL  
 HOURMETER/DIAGNOSTIC -  
 ISB10 MPH  
 SIZE DWG. NO. 91780-A1  
 SCALE: 1:1 | WEIGHT: 0.50 | SHEET 1 OF 1

91780-A1  
 D



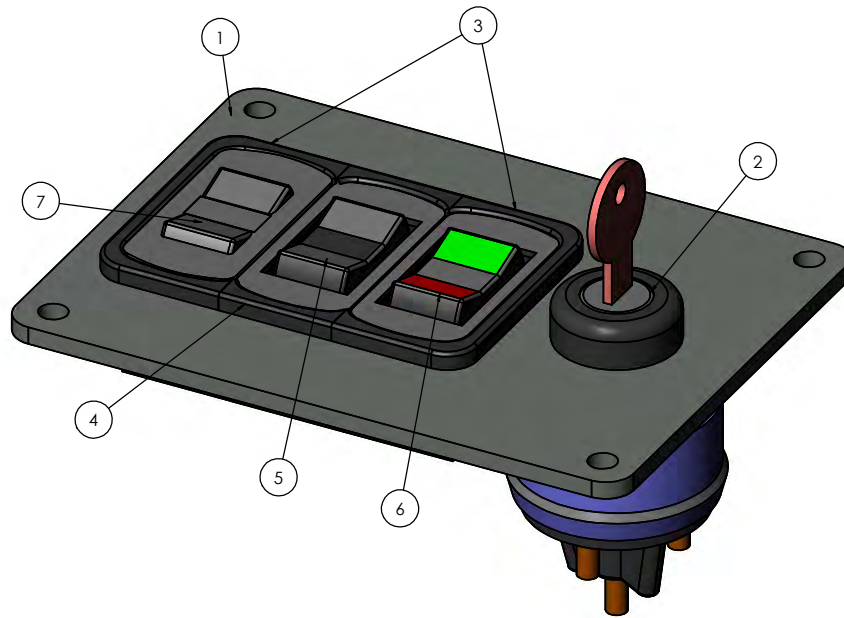

DIMENSIONS ARE IN INCHES		NAME	DATE	TICO MANUFACTURING
TOLERANCES:		DRAWN	ADW	66 CYPRESS RIDGE DR.
DECIMAL	.005	CHECKED		ROCKLAND, NC 27854
ANGULAR	0.1°	APPROVED		TICORACTORS.COM
FRACTIONAL	1/32	DO NOT SCALE DRAWING		
INSURE GEOMETRIC TOLERANCING PER ASME Y14.5M-1994		THE SUBJECT MATTER SHOWN AND DESCRIBED IN THIS DRAWING AND ANY OTHER INFORMATION CONTAINED IN CONNECTION HEREWITH IS TO BE CONSIDERED PROPERTY OF TICO. ALL RIGHTS TO ANY PATENTS, TRADE MARKS AND COPYRIGHTS DESCRIBED ARE RESERVED BY TICO MANUFACTURING, INC.		TITLE: PANEL ASSY DASH KEY IGNITION SWITCH-5B10
SIZE	D	SCALE: 1:1	WEIGHT: 0.38	REV SHEET 1 OF 1

D 91605-A1



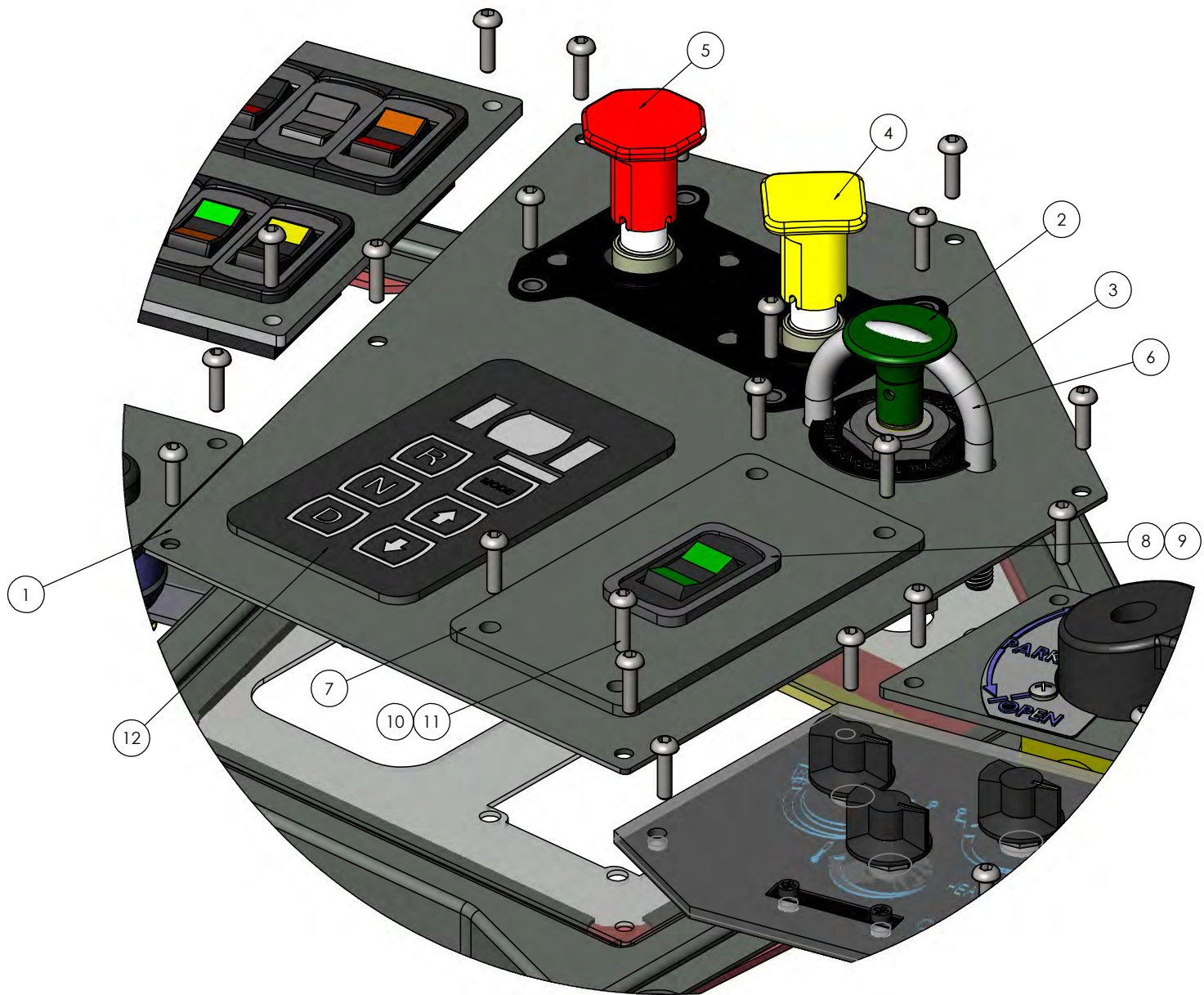

DIMENSIONS ARE IN INCHES		NAME	DATE	TICO MANUFACTURING 66 CYPRESS RIDGE DR. ROSELAND, NC 28088 TICORACTORS.COM
DECIMAL	XXX.XX	ADW	04/03/2020	
ANGULAR	XX.X			<b>TITLE:</b> DASH ASSY, PANEL 2 VALVE, ELEC, PB SHIFT  <b>SIZE:</b> DWG. NO. 20184-A1 <b>SCALE:</b> 1:4   <b>WEIGHT:</b> 18.24   <b>SHEET 1 OF 1</b>
FUNCTIONAL	XX.X			
INSPIRE GEOMETRIC COLORING FOR NAME & DAY PIV		DO NOT SCALE DRAWING		<small>           THE SUBJECT MATTER SHOWN AND            DESCRIBED IN THIS DRAWING AND ANY            OTHER REFERENCE TO INVENTION IN            CONNECTION HERWITH IS TO BE            CONSIDERED TO BE THE            PROPERTY OF TICO MANUFACTURING            AND ANY RIGHTS TO ANY INVENTIONS            OR PATENTS ARE RESERVED BY TICO MANUFACTURING            COMPANY.         </small>
DATE				
REV				
ISSUES				

D 20184-A1





DIMENSIONS ARE IN INCHES		NAME	DATE	TICO MANUFACTURING
TOLERANCES:		DRAWN	ADW	04/22/2020
DECIMAL	.005	CHECKED		44 CYPRESS RIDGE DR.
FRACTIONAL	1/32	APPROVED		ROCKLAND, NC 28574
ANGULAR	± 0.1°			TICORACTORS.COM
FUNCTIONAL	± 0.02			
INSURE GEOMETRIC TOLERANCING PER ASME Y14.5M		DO NOT SCALE DRAWING		
UNLESS OTHERWISE SPECIFIED, ALL DIMENSIONS ARE TO BE TAKEN FROM THE DIMENSIONED SURFACE UNLESS OTHERWISE INDICATED.		THE SUBJECT MATTER SHOWN AND DESCRIBED IN THIS DRAWING AND ANY OTHER INFORMATION CONTAINED HEREIN IS THE PROPERTY OF TICO MANUFACTURING, INC. AND IS TO BE KEPT IN CONFIDENCE BY ALL PARTS TO WHOM IT IS FURNISHED. NO PARTS, INFORMATION, PROCESS, NAME, AND COMPANY LOGOS ARE TO BE REPRODUCED OR USED FOR ANY OTHER PURPOSE WITHOUT THE WRITTEN PERMISSION OF TICO MANUFACTURING, INC.		
DATE:	04/22/2020	SIZE	DWG. NO.	REV
REV:		D	20292-A1	
DRAWN:	ADW	SCALE:	1:1	WEIGHT: 0.27
CHECKED:				SHEET 1 OF 1

D 20292-A1 001

