

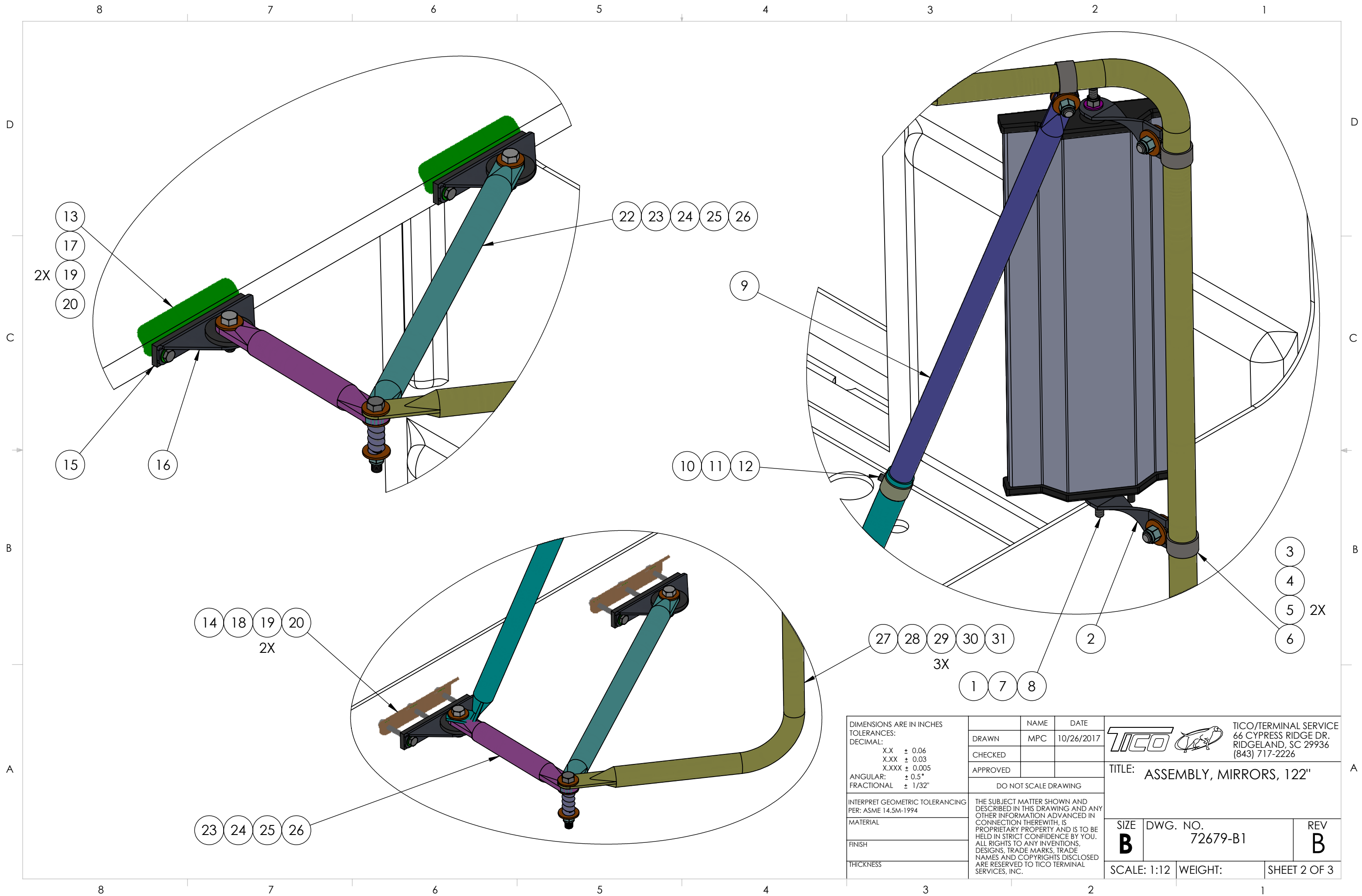

DIMENSIONS ARE IN INCHES		NAME	DATE	 TICO/TERMINAL SERVICE 66 CYPRESS RIDGE DR. RIDGELAND, SC 29936 (843) 717-2226
TOLERANCES:		DRAWN	MPC 10/26/2017	
DECIMAL:		CHECKED		
X.X ± 0.06 X.XX ± 0.03 X.XXX ± 0.005		APPROVED		
ANGULAR:		DO NOT SCALE DRAWING		TITLE: ASSEMBLY, MIRRORS, 122"
FRACTIONAL ± 1/32"				
INTERPRET GEOMETRIC TOLERANCING PER: ASME 14.5M-1994		THE SUBJECT MATTER SHOWN AND DESCRIBED IN THIS DRAWING AND ANY OTHER INFORMATION ADVANCED IN CONNECTION THEREWITH, IS PROPRIETARY PROPERTY AND IS TO BE HELD IN STRICT CONFIDENCE BY YOU. ALL RIGHTS TO ANY INVENTIONS, DESIGNS, TRADE MARKS, TRADE NAMES AND COPYRIGHTS DISCLOSED ARE RESERVED TO TICO TERMINAL SERVICES, INC.		
MATERIAL		SIZE	DWG. NO.	REV
FINISH		B	72679-B1	B
THICKNESS		SCALE: 1:12	WEIGHT:	SHEET 1 OF 3



DIMENSIONS ARE IN INCHES		NAME	DATE
TOLERANCES:		DRAWN	MPC 10/26/2017
DECIMAL:		CHECKED	
X.X ± 0.06		APPROVED	
X.XX ± 0.03		DO NOT SCALE DRAWING	
X.XXX ± 0.005		THE SUBJECT MATTER SHOWN AND DESCRIBED IN THIS DRAWING AND ANY OTHER INFORMATION ADVANCED IN CONNECTION THEREWITH, IS PROPRIETARY PROPERTY AND IS TO BE HELD IN STRICT CONFIDENCE BY YOU. ALL RIGHTS TO ANY INVENTIONS, DESIGNS, TRADE MARKS, TRADE NAMES AND COPYRIGHTS DISCLOSED ARE RESERVED TO TICO TERMINAL SERVICES, INC.	
ANGULAR:			
FRACTIONAL ± 1/32"			
INTERPRET GEOMETRIC TOLERANCING PER: ASME 14.5M-1994			
MATERIAL			
FINISH			
THICKNESS			

 TICO/TERMINAL SERVICE 66 CYPRESS RIDGE DR. RIDGELAND, SC 29936 (843) 717-2226		TITLE: ASSEMBLY, MIRRORS, 122"	
SIZE B	DWG. NO. 72679-B1	REV B	
SCALE: 1:12	WEIGHT:	SHEET 2 OF 3	

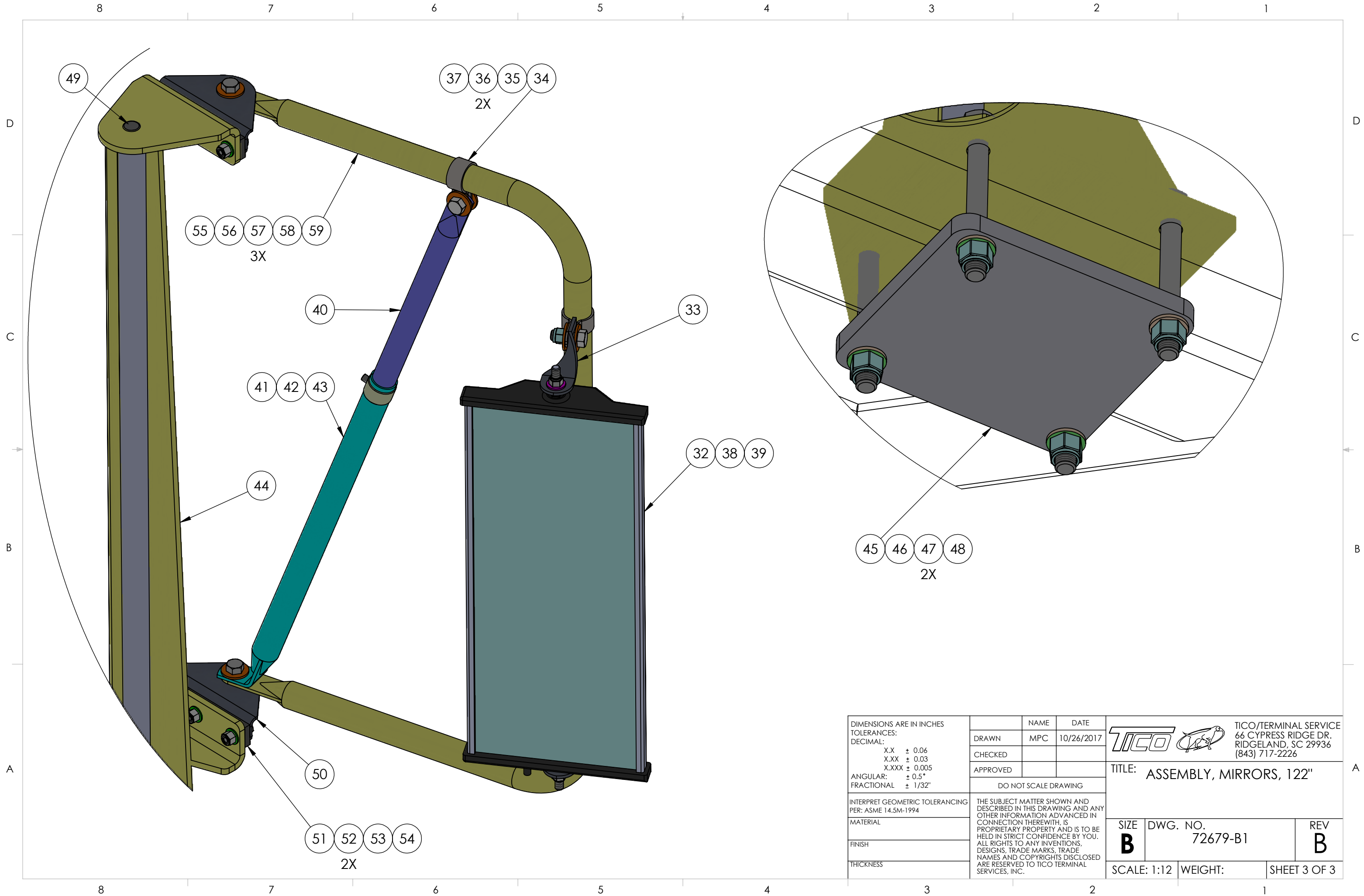

DIMENSIONS ARE IN INCHES
 TOLERANCES:
 DECIMAL:
 X.X ± 0.06
 X.XX ± 0.03
 X.XXX ± 0.005
 ANGULAR: ± 0.5°
 FRACTIONAL ± 1/32"

INTERPRET GEOMETRIC TOLERANCING PER: ASME 14.5M-1994

MATERIAL

FINISH

THICKNESS

	NAME	DATE
DRAWN	MPC	10/26/2017
CHECKED		
APPROVED		



TICO/TERMINAL SERVICE
 66 CYPRESS RIDGE DR.
 RIDGELAND, SC 29936
 (843) 717-2226

TITLE: ASSEMBLY, MIRRORS, 122"

THE SUBJECT MATTER SHOWN AND DESCRIBED IN THIS DRAWING AND ANY OTHER INFORMATION ADVANCED IN CONNECTION THEREWITH, IS PROPRIETARY PROPERTY AND IS TO BE HELD IN STRICT CONFIDENCE BY YOU. ALL RIGHTS TO ANY INVENTIONS, DESIGNS, TRADE MARKS, TRADE NAMES AND COPYRIGHTS DISCLOSED ARE RESERVED TO TICO TERMINAL SERVICES, INC.

SIZE B	DWG. NO. 72679-B1	REV B
SCALE: 1:12	WEIGHT:	SHEET 3 OF 3

