

1

2 3 4
2X

8 9 10
2X

7

5

6

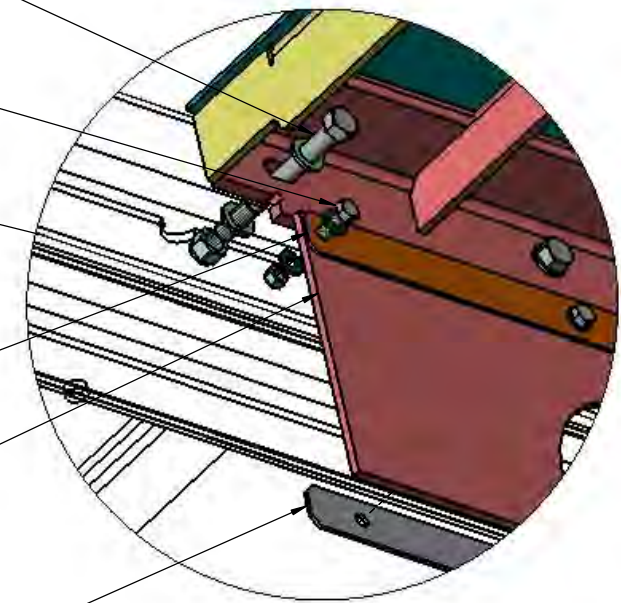

DETAIL A
SCALE 1 : 3

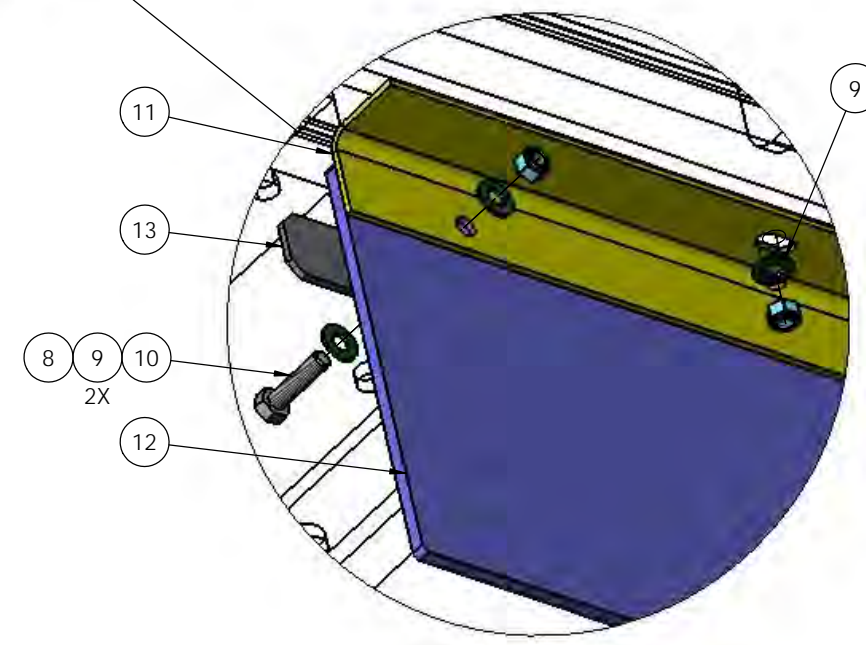

DETAIL B
SCALE 1 : 2

DIMENSIONS ARE IN INCHES
 TOLERANCES:
 DECIMAL:
 .XX ± 0.06
 .XXX ± 0.03
 .XXXX ± 0.005
 ANGULAR:
 FRACTIONAL ± 1/32"
 INTERPRET GEOMETRIC TOLERANCING PER: ASME 14.5M-1994
 MATERIAL
 FINISH
 THICKNESS

NAME	DATE
DRAWN RWC	10/28/2012
REVISED MPC	09/15/2016
APPROVED	

DO NOT SCALE DRAWING

THE SUBJECT MATTER SHOWN AND DESCRIBED IN THIS DRAWING AND ANY OTHER INFORMATION ADVANCED IN CONNECTION THEREWITH IS PROPRIETARY PROPERTY AND IS TO BE HELD IN STRICT CONFIDENCE BY YOU. ALL RIGHTS TO ANY INVENTIONS, DESIGNS, TRADE MARKS, TRADE NAMES AND COPYRIGHTS DISCLOSED ARE RESERVED TO TICO TERMINAL SERVICES, INC.

TICO/TERMINAL SERVICE 66 CYPRESS RIDGE DR. RIDGELAND, SC 29936 (843) 717-2226	
TITLE:	
ASSEMBLY, FENDER CAB FLOOR, QSB TIER IV	
SIZE	DWG. NO.
C	72655-A1
REV	
	SHEET 1 OF 1

