

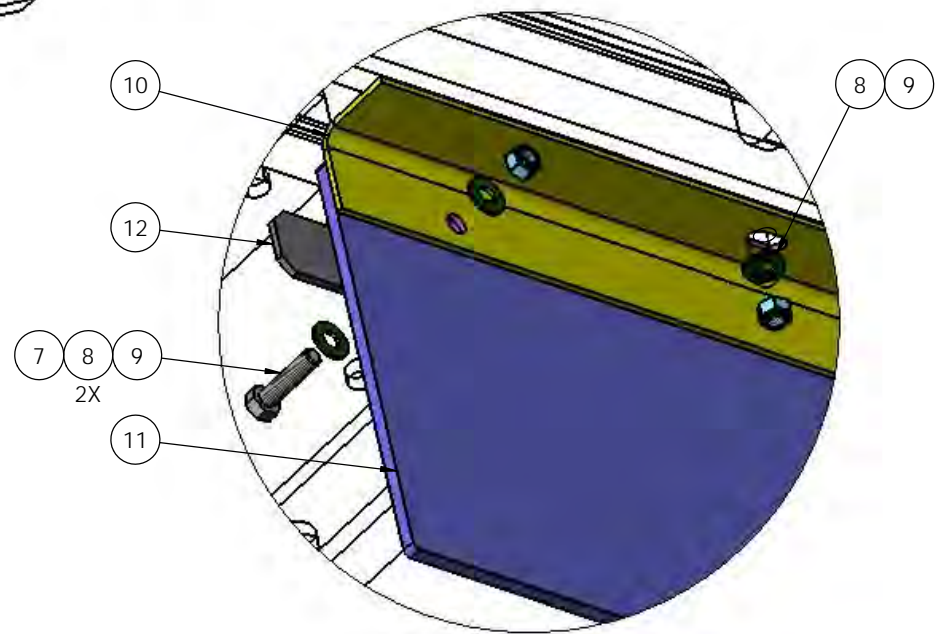

DETAIL A  
SCALE 1 : 2



DETAIL B  
SCALE 1 : 2

DIMENSIONS ARE IN INCHES		NAME	DATE	 TICO/TERMINAL SERVICE 66 CYPRESS RIDGE DR. RIDGELAND, SC 29936 (843) 717-2226
TOLERANCES:		DRAWN	RWC 10/28/2012	
DECIMAL:		REVISED	MPC 06/20/2016	
.XX ± 0.06 .XXX ± 0.03 .XXXX ± 0.005 ANGULAR: FRACTIONAL: ± 1/32"		APPROVED		
DO NOT SCALE DRAWING				TITLE:
INTERPRET GEOMETRIC TOLERANCING PER: ASME 14.5M-1994 MATERIAL FINISH THICKNESS				FENDER, CAB FLOOR QSB TIER III SIZE C DWG. NO. 72654-A1 REV
				SHEET 1 OF 1

