

DIMENSIONS ARE IN INCHES		NAME	DATE	 TICO/TERMINAL SERVICE 66 CYPRESS RIDGE DR. RIDGELAND, SC 29936 (843) 717-2226	
TOLERANCES:		DRAWN	SMB		2/6/15
DECIMAL:		CHECKED			
X.X ± 0.06 X.XX ± 0.03 X.XXX ± 0.005		APPROVED			
ANGULAR: ± 0.5°		DO NOT SCALE DRAWING			
FRACTIONAL ± 1/32"		THE SUBJECT MATTER SHOWN AND DESCRIBED IN THIS DRAWING AND ANY OTHER INFORMATION ADVANCED IN CONNECTION THEREWITH, IS PROPRIETARY PROPERTY AND IS TO BE HELD IN STRICT CONFIDENCE BY YOU. ALL RIGHTS TO ANY INVENTIONS, DESIGNS, TRADE MARKS, TRADE NAMES AND COPYRIGHTS DISCLOSED ARE RESERVED TO TICO TERMINAL SERVICES, INC.			
INTERPRET GEOMETRIC TOLERANCING PER: ASME 14.5M-1994		TITLE:			
MATERIAL		FRAME ASSEMBLY, 116", GALVANIZED			
FINISH		SIZE	DWG. NO.	REV	
THICKNESS		B	72650-C1		
		SCALE: 1:50	WEIGHT:	SHEET 1 OF 1	

REV.	DESCRIPTION	ECN	DATE	APPROVED
A	RELEASE	15113	1/16/2015	

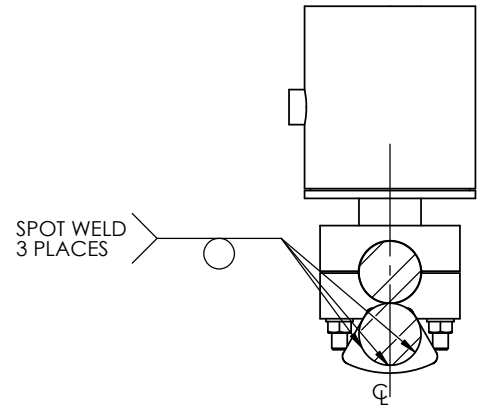
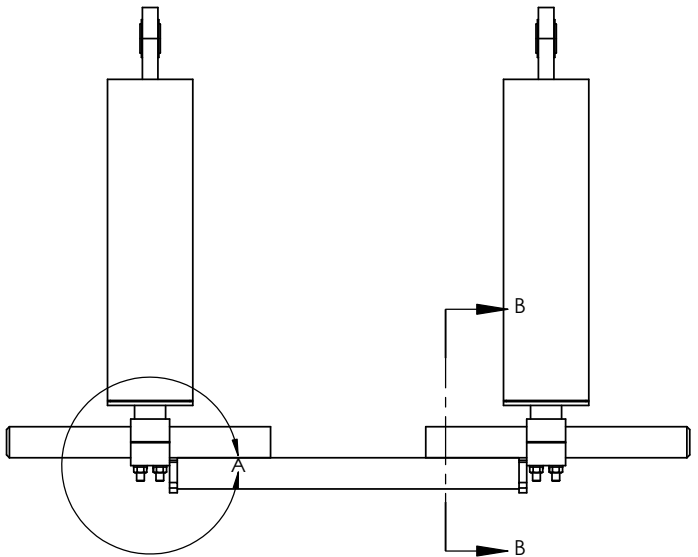

NOTE: CENTER LINE OF CYLINDER STOP SHOULD BE ORIENTED ALONG THE CENTER LINE OF THE LOWER CYLINDER PIN ASSEMBLY

**SECTION B-B
SCALE 1 : 4**

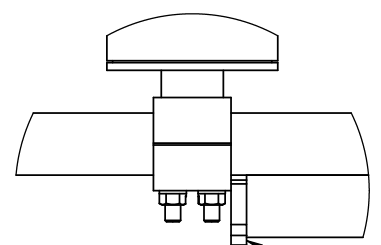

**DETAIL A
SCALE 1 : 4**

**NOTE: CYLINDER STOP SHOULD BE FLUSH TO CENTER SHAFT OF LOWER CYLINDER PIN.
NOTE: USE 120021-1, 120021-2, OR 120021-3 BASED ON NATURAL POSITION OF THE CYLINDER WHEN ATTACHED TO BOOM.**

DIMENSIONS ARE IN INCHES		NAME	DATE	 TICO/TERMINAL SERVICE 66 CYPRESS RIDGE DR. RIDGELAND, SC 29936 (843) 717-2226	
TOLERANCES:		DRAWN	MG		1/16/15
DECIMAL:		CHECKED			
.XX ± 0.06 .XXX ± 0.03 .XXXX ± 0.005		APPROVED			
ANGULAR: ± 0.5°		DO NOT SCALE DRAWING			
FRACTIONAL: ± 1/32"		THE SUBJECT MATTER SHOWN AND DESCRIBED IN THIS DRAWING AND ANY OTHER INFORMATION ADVANCED IN CONNECTION THEREWITH, IS PROPRIETARY PROPERTY AND IS TO BE HELD IN STRICT CONFIDENCE BY YOU. ALL RIGHTS TO ANY INVENTIONS, DESIGNS, TRADE MARKS, TRADE NAMES AND COPYRIGHTS DISCLOSED ARE RESERVED TO TICO TERMINAL SERVICES, INC.			
INTERPRET GEOMETRIC TOLERANCING PER: ASME 14.5M-1994		SIZE		DWG. NO.	
MATERIAL		B		120021	
FINISH		REV		A	
THICKNESS		SCALE: 1:8		WEIGHT: 214.85 SHEET 1 OF 1	