

11 12 13
2X

DETAIL C
SCALE 1 : 3

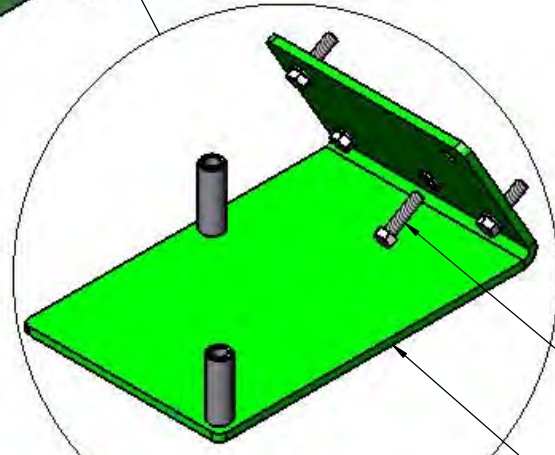

4 5 6
2X

DETAIL A
SCALE 1 : 3

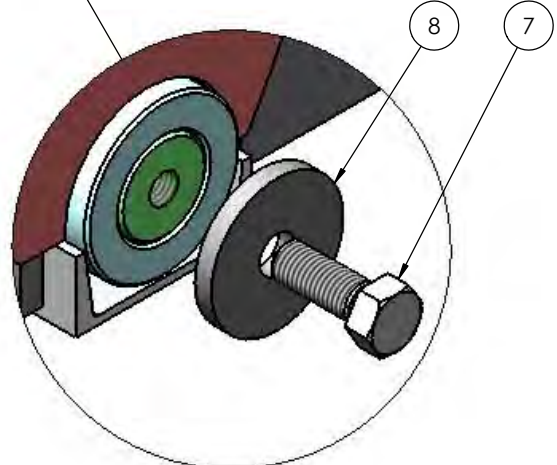

DETAIL B
SCALE 1 : 2

DIMENSIONS ARE IN INCHES

TOLERANCES:
DECIMAL:
XX ± 0.06
XXX ± 0.03
XXXX ± 0.005

ANGULAR:
FRACTIONAL ± 1/32"

INTERPRET GEOMETRIC TOLERANCING PER: ASME 14.5M-1994

MATERIAL

FINISH

THICKNESS

NAME	DATE
DRAWN DFM	12/21/2015
REVISED MPC	08/03/2016
APPROVED	

DO NOT SCALE DRAWING

THE SUBJECT MATTER SHOWN AND DESCRIBED IN THIS DRAWING AND ANY OTHER INFORMATION ADVANCED IN CONNECTION THEREWITH IS PROPRIETARY PROPERTY AND IS TO BE HELD IN STRICT CONFIDENCE BY YOU. ALL RIGHTS TO ANY INVENTIONS, DESIGNS, TRADE MARKS, TRADE NAMES AND COPYRIGHTS DISCLOSED ARE RESERVED TO TICO TERMINAL SERVICES, INC.

TICO/TERMINAL SERVICE 66 CYPRESS RIDGE DR. RIDGELAND, SC 29936 (843) 717-2226	
TITLE: ASSEMBLY, FRAME PORT TRUCK, 116" WB, 2°	
SIZE C	DWG. NO. 72607-B1
REV	SHEET 1 OF 1

