

11 12 13
2X

DETAIL C
SCALE 1 : 3

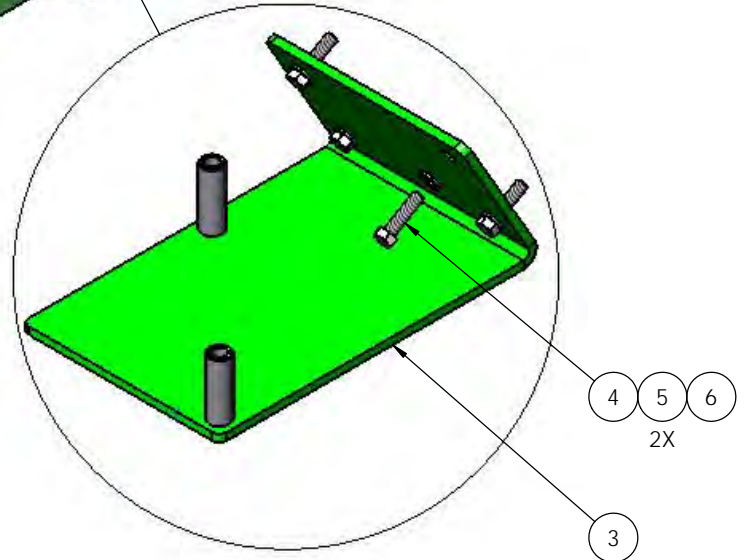

4 5 6
2X

DETAIL A
SCALE 1 : 3

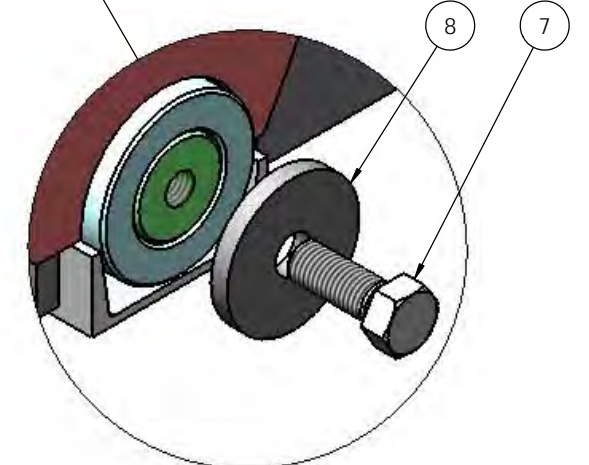

DETAIL B
SCALE 1 : 2

DIMENSIONS ARE IN INCHES

TOLERANCES:	NAME	DATE
DECIMAL:	DRAWN	DFM 12/21/2015
XX ± 0.06	REVISED	MPC 08/03/2016
XXX ± 0.03	APPROVED	
XXXX ± 0.005		
ANGULAR:	DO NOT SCALE DRAWING	
FRACTIONAL ± 1/32"		
INTERPRET GEOMETRIC TOLERANCING PER: ASME 14.5M-1994	THE SUBJECT MATTER SHOWN AND DESCRIBED IN THIS DRAWING AND ANY OTHER INFORMATION ADVANCED IN CONNECTION THEREWITH IS PROPRIETARY PROPERTY AND IS TO BE HELD IN STRICT CONFIDENCE BY YOU. ALL RIGHTS TO ANY INVENTIONS, DESIGNS, TRADE MARKS, TRADE NAMES AND COPYRIGHTS DISCLOSED ARE RESERVED TO TICO TERMINAL SERVICES, INC.	
FINISH		
THICKNESS		

TICO TERMINAL SERVICE		
66 CYPRESS RIDGE DR. RIDGELAND, SC 29936 (843) 717-2226		
TITLE: ASSEMBLY, FRAME PORT TRUCK, 116" WB, 2°		
SIZE C	DWG. NO. 72539-D1	REV

SHEET 1 OF 1	
--------------	--

