

8 7 6 5 4 3 2 1

F
E
D
C
B
A

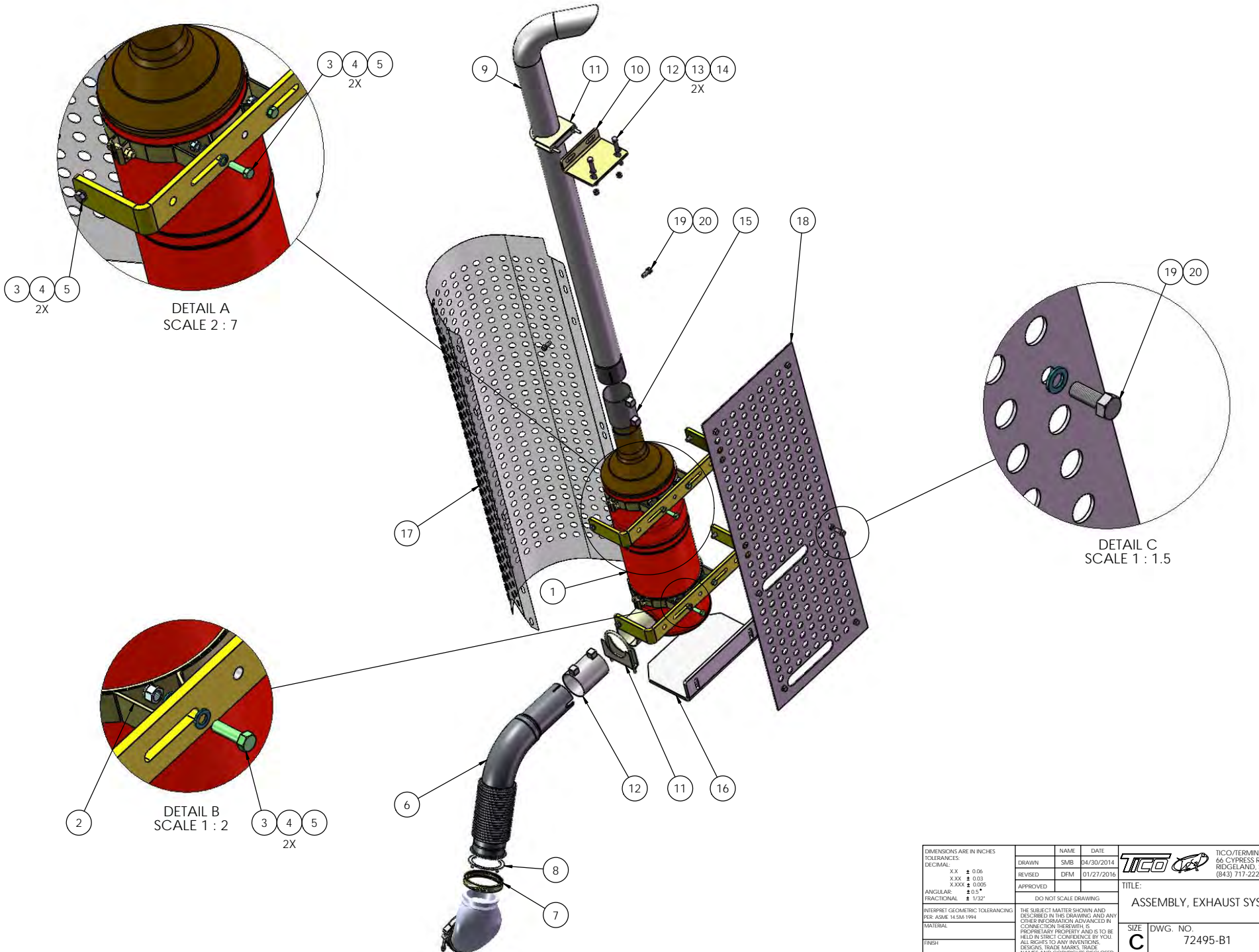

DETAIL A
SCALE 2 : 7

DETAIL B
SCALE 1 : 2

DETAIL C
SCALE 1 : 1.5

DIMENSIONS ARE IN INCHES		NAME	DATE	 TICO/TERMINAL SERVICE 66 CYPRESS RIDGE DR. RIDGELAND, SC 29936 (843) 717-2226	
TOLERANCES:		DRAWN	SMB		04/30/2014
DECIMAL:		REVISED	DFM		01/27/2016
.XX ± 0.06 .XXX ± 0.03 .XXXX ± 0.005 ANGULAR ± 0.5° FRACTIONAL ± 1/32"		APPROVED			
DO NOT SCALE DRAWING THE SUBJECT MATTER SHOWN AND DESCRIBED IN THIS DRAWING AND ANY OTHER INFORMATION ADVANCED IN CONNECTION THEREWITH IS PROPRIETARY PROPERTY AND IS TO BE HELD IN STRICT CONFIDENCE BY YOU. ALL RIGHTS TO ANY INVENTIONS, DESIGNS, TRADE MARKS, TRADE NAMES AND COPYRIGHTS DISCLOSED ARE RESERVED TO TICO TERMINAL SERVICES, INC.				TITLE:	
INTERPRET GEOMETRIC TOLERANCING PER: ASME 14.5M-1994		SIZE		DWG. NO.	
MATERIAL		C		72495-B1	
FINISH		REV			
THICKNESS		SHEET 1 OF 1			

8 7 6 5 4 3 2 1

