

DETAIL H
SCALE 1 : 4

DETAIL G
SCALE 1 : 3

DETAIL F
SCALE 1 : 3

DETAIL E
SCALE 1 : 3

DETAIL D
SCALE 1 : 2

DETAIL C
SCALE 1 : 2

DETAIL B
SCALE 1 : 5

DETAIL A
SCALE 1 : 2

DIMENSIONS ARE IN INCHES TOLERANCES: DECIMAL: X.X ± 0.04 X.XX ± 0.03 X.XXX ± 0.005 ANGULAR: ± 0.5° FRACTIONAL: ± 1/32"		NAME RWC	DATE 8/03/12	 TICO/TERMINAL SERVICE 64 CYPRESS RIDGE DR. RIDGELAND, SC 29936 (843) 717-2226
INTERPRET GEOMETRIC TOLERANCING PER: ASME Y14.5M-1994		CHECKED	APPROVED	
THE SUBJECT MATTER SHOWN AND DESCRIBED IN THIS DRAWING AND ANY OTHER INFORMATION ADVANCED IN CONNECTION THEREWITH IS PROPRIETARY PROPERTY AND IS TO BE HELD IN STRICT CONFIDENCE BY YOU. ALL RIGHTS TO ANY INVENTIONS, DESIGNS, TRADE MARKS, TRADE NAMES AND COPYRIGHTS DISCLOSED ARE RESERVED TO TICO/TERMINAL SERVICES, INC.		DO NOT SCALE DRAWING TITLE: AIR SYSTEM, 2-TANK		
FINISH	THICKNESS	SIZE D	DWG. NO. 72486-B1	REV 1
		SCALE: 1:50 WEIGHT: 3539.42 SHEET 1 OF 1		

REV 1
D 72486-B1

TICO PRO-SPOTTER				
S/N:		AIR SYSTEM - OFF ROAD, R-14, QR-1, AUTO NEUTRAL		72486
ITEM	PART #	QTY/M	DESCRIPTION	TASK
	72486-B1	REF	AIR SYSTEM, 2-TANKS	
	62376	REF	SCHEMATIC- STD SYSTEM, 2 TANKS, AUTO NEUTRAL	
1	42087	1	ASSEMBLY, AIR TANK	
2	60023	1	GOVERNOR, D2 W/GASKET	
3	90026	1	BRAKE PEDAL	
4	90057	1	VALVE, BRAKE, E-3	
5	42061	1	VALVE, RELAY, R-14	
6	40550	2	VALVE, BRAKE QUICK RELEASE, QR-1	
7	90069	1	VALVE, TRACTOR PROTECTION	
8	90078	2	SWITCH, PRESSURE	
9	10949	1	MANIFOLD, ASS'Y AIR	
10	90295	1	VALVE, AIR REGULATOR	
11	40148	1	VALVE, AIR TANK DRAIN	
12	40776	1	SWITCH, LOW AIR PRESSURE, 70 PSI	
13	90873	1	BUZZER, LOW AIR WARNING, 70 PSI	
14	61704	1	BRACKET, STAND OFF	
	90095	REF	VALVE, TRAILER BRAKE	
	90094	REF	VALVE, TRACTOR BRAKE	
15	50038-1	3	GLADHAND, BLUE	
16	50039-1	3	GLADHAND, RED	
17	50303	2	HOSE ASSEMBLY, TRAILER AIR, 3/8 X 15'	
18	10356	1	SPRING	
19	40080	2	CLAMP, TRAILER HOSE	
20	40687	2	HOSE ASSY, FRONT BRAKE CHAMBER	
21	40817	1	FITTING, 90° ELBOW, STREET, 1/2 MPT X 5/8 TUBE	
22	42064	1	PUSHCONNECT, 90° BRASS, 1/2 MPT X 1/2 TUBE	
23	40900	1	TEE, STREET, PIPE, 1/4 NPT	
24	40029-1	1	VALVE, CHECK	
25	40799	2	FITTING, CLOSE NIPPLE, BRASS, 1/2 NPT	
26	40899	2	ELBOW, 45°, BRASS, 1/2 MPT X 1/2 FPT	
27	42084	1	VALVE, AIR TANK DRAIN	
REV	DATE	BY		SHEET
				1 OF 1

TICO MANUFACTURING - RIDGELAND, SC 29936

REV.	DESCRIPTION	ECN	DATE	APPROVED
A	RELEASED	14348	7-16-2014	

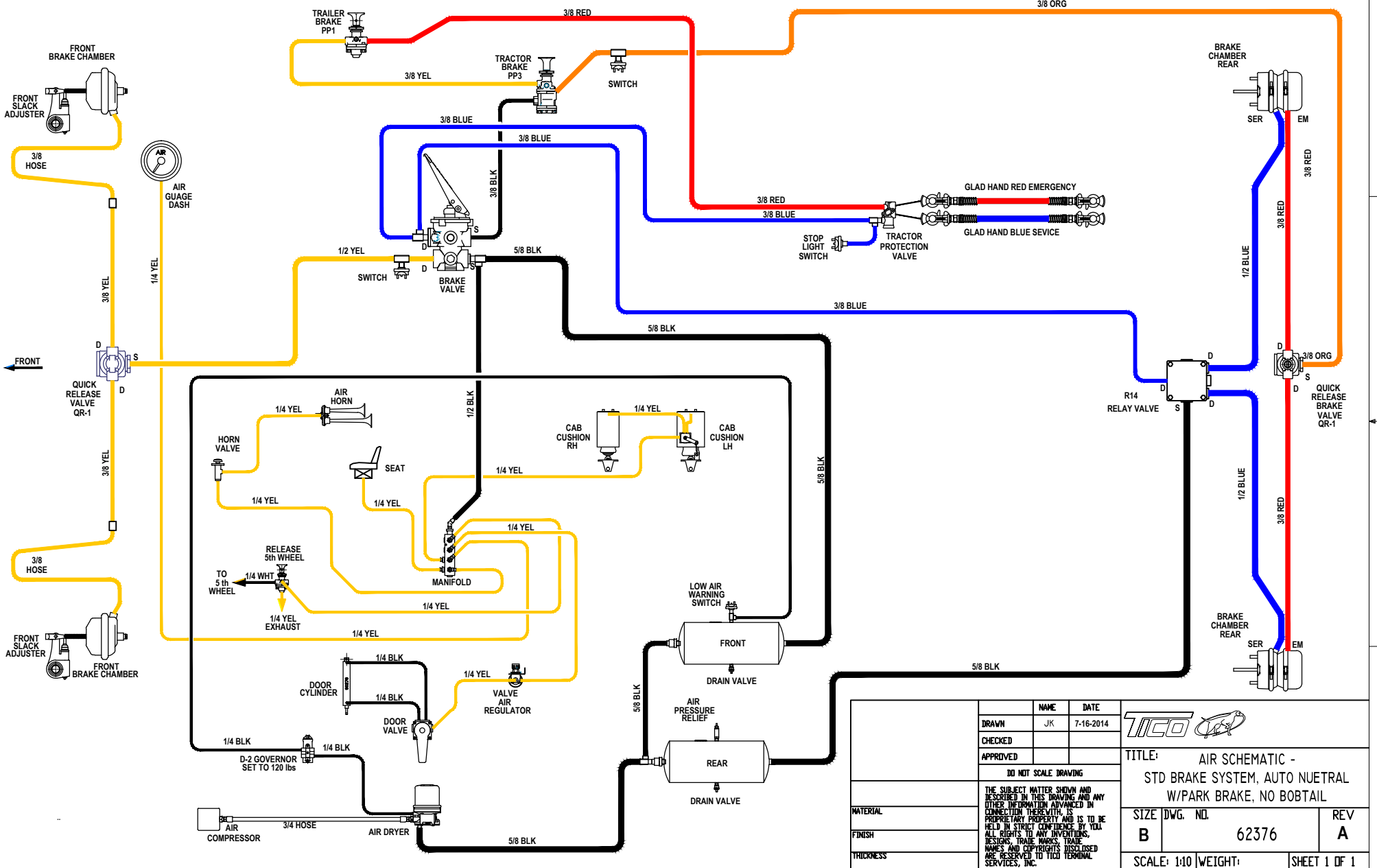

	NAME	DATE	
DRAWN	JK	7-16-2014	
CHECKED			
APPROVED			TITLE: AIR SCHEMATIC - STD BRAKE SYSTEM, AUTO NEUTRAL W/PARK BRAKE, NO BOBTAIL
DO NOT SCALE DRAWING			
<small>THE SUBJECT MATTER SHOWN AND DESCRIBED IN THIS DRAWING AND ANY OTHER INFORMATION ADVANCED IN CONNECTION THEREWITH, IS PROPRIETARY PROPERTY AND IS TO BE HELD IN STRICT CONFIDENCE BY YOU. ALL RIGHTS TO ANY INVENTIONS, DESIGNS, TRADE MARKS, TRADE NAMES AND COPYRIGHTS DISCLOSED ARE RESERVED TO TICO TERMINAL SERVICES, INC.</small>			
MATERIAL			SIZE DWG. NO. B 62376
FINISH			REV A
THICKNESS			SCALE: 1:10 WEIGHT: SHEET 1 OF 1