

8 7 6 5 4 3 2 1

D

D

C

C

B

B

A

A

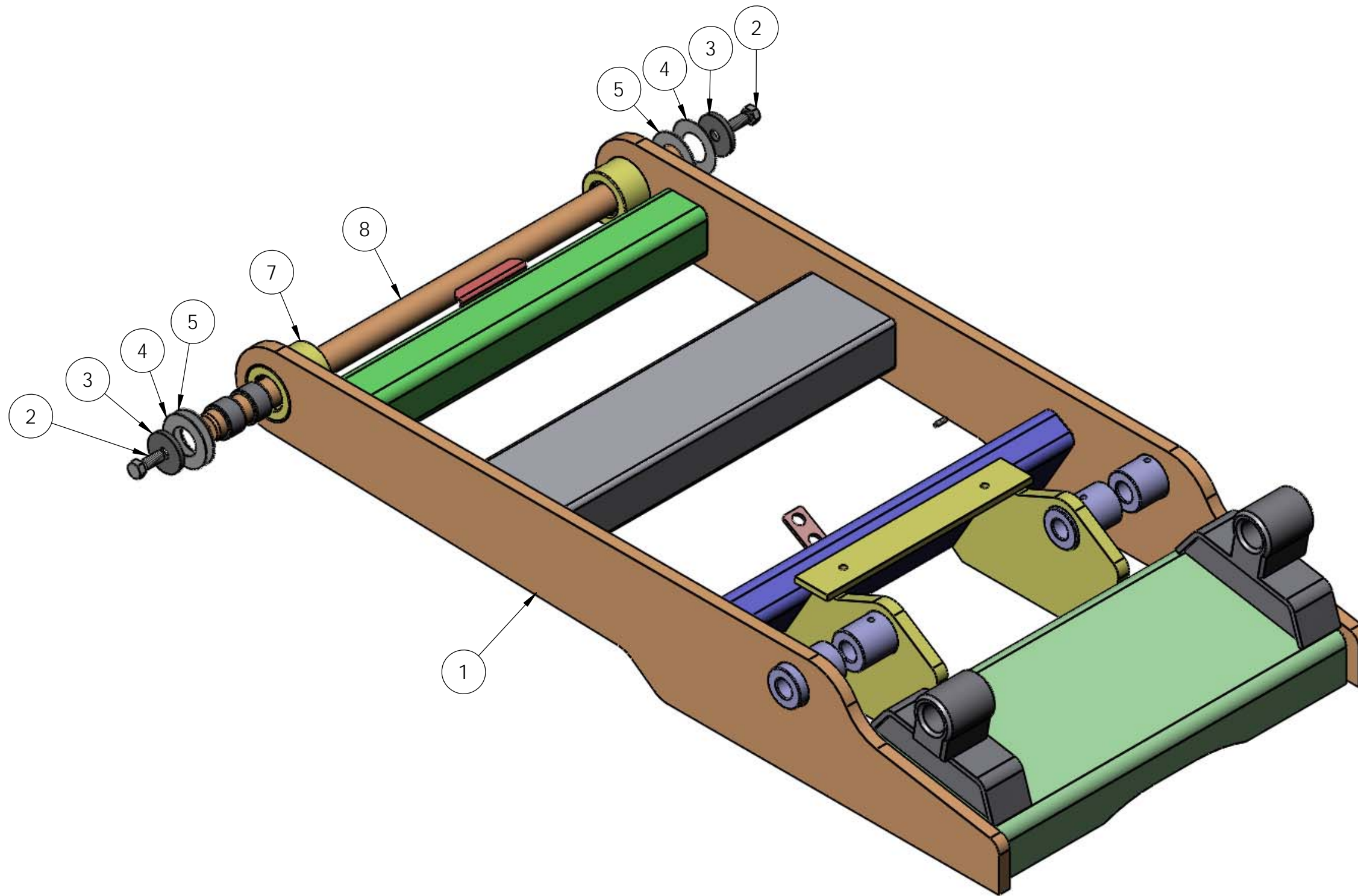

NOTE: 4 5 AS REQUIRED

DIMENSIONS ARE IN INCHES		NAME	DATE	 TICO/TERMINAL SERVICE 66 CYPRESS RIDGE DR. RIDGELAND, SC 29936 (843) 717-2226					
TOLERANCES:		DRAWN	SMB		9/23/15				
DECIMAL:		CHECKED							
X.X ± 0.12 X.XX ± 0.06 X.XXX ± 0.005		APPROVED							
ANGULAR: ± 1°		DO NOT SCALE DRAWING			TITLE:				
FRACTIONAL ± 1/16"					BOOM ASSEMBLY				
INTERPRET GEOMETRIC TOLERANCING PER: ASME 14.5M-1994		THE SUBJECT MATTER SHOWN AND DESCRIBED IN THIS DRAWING AND ANY OTHER INFORMATION ADVANCED IN CONNECTION THEREWITH, IS PROPRIETARY PROPERTY AND IS TO BE HELD IN STRICT CONFIDENCE BY YOU. ALL RIGHTS TO ANY INVENTIONS, DESIGNS, TRADE MARKS, TRADE NAMES AND COPYRIGHTS DISCLOSED ARE RESERVED TO TICO TERMINAL SERVICES, INC.			SIZE	DWG. NO.	REV		
MATERIAL					<b>B</b>	72404-B1	<b>C</b>		
FINISH					SCALE: 1:8			WEIGHT:	SHEET 1 OF 1
THICKNESS									

8 7 6 5 4 3 2 1

