

DETAIL G  
SCALE 1 : 4

DETAIL F  
SCALE 1 : 3

DETAIL E  
SCALE 1 : 3

DETAIL D  
SCALE 1 : 2

DETAIL C  
SCALE 1 : 2

DETAIL A  
SCALE 1 : 2

DETAIL B  
SCALE 1 : 5

DIMENSIONS ARE IN INCHES		NAME	DATE	 TICO/TERMINAL SERVICE 44 CYPRESS RIDGE DR. RIDGELAND, SC 29936 (843) 717-2226	
TOLERANCES:		DRAWN	RWC		8/03/12
DECIMAL:		CHECKED			
.XX ± 0.04		APPROVED			
.XXX ± 0.03		DO NOT SCALE DRAWING			
.XXX ± 0.005		THE SUBJECT MATTER SHOWN AND DESCRIBED IN THIS DRAWING AND ANY OTHER INFORMATION ADVANCED IN CONNECTION THEREWITH IS PROPRIETARY PROPERTY AND IS TO BE HELD IN STRICT CONFIDENCE BY YOU. ALL RIGHTS TO ANY INVENTIONS, DESIGNS, TRADE MARKS, TRADE NAMES AND COPYRIGHTS DISCLOSED ARE RESERVED TO TICO/TERMINAL SERVICES, INC.			
ANGULAR: ± 0.5°		TITLE: AIR SYSTEM, 2-TANK			
FRACTIONAL: ± 1/32"		SIZE DWG. NO. 72370-B1			
INTERPRET GEOMETRIC TOLERANCING PER: ASME Y14.5M-1994		REV			
MATERIAL		SCALE: 1:50 WEIGHT: 3542.12 SHEET 1 OF 1			
FINISH					
THICKNESS					



REV.	DESCRIPTION	ECN	DATE	APPROVED
A	PRODUCTION RELEASE	04/20	11/8/10	HK
B	REMOVED 2" BLUE LINE	04/63	12/3/10	HK
C	REVISED AIR TANKS ROUTING	04/63	5/10/11	HK

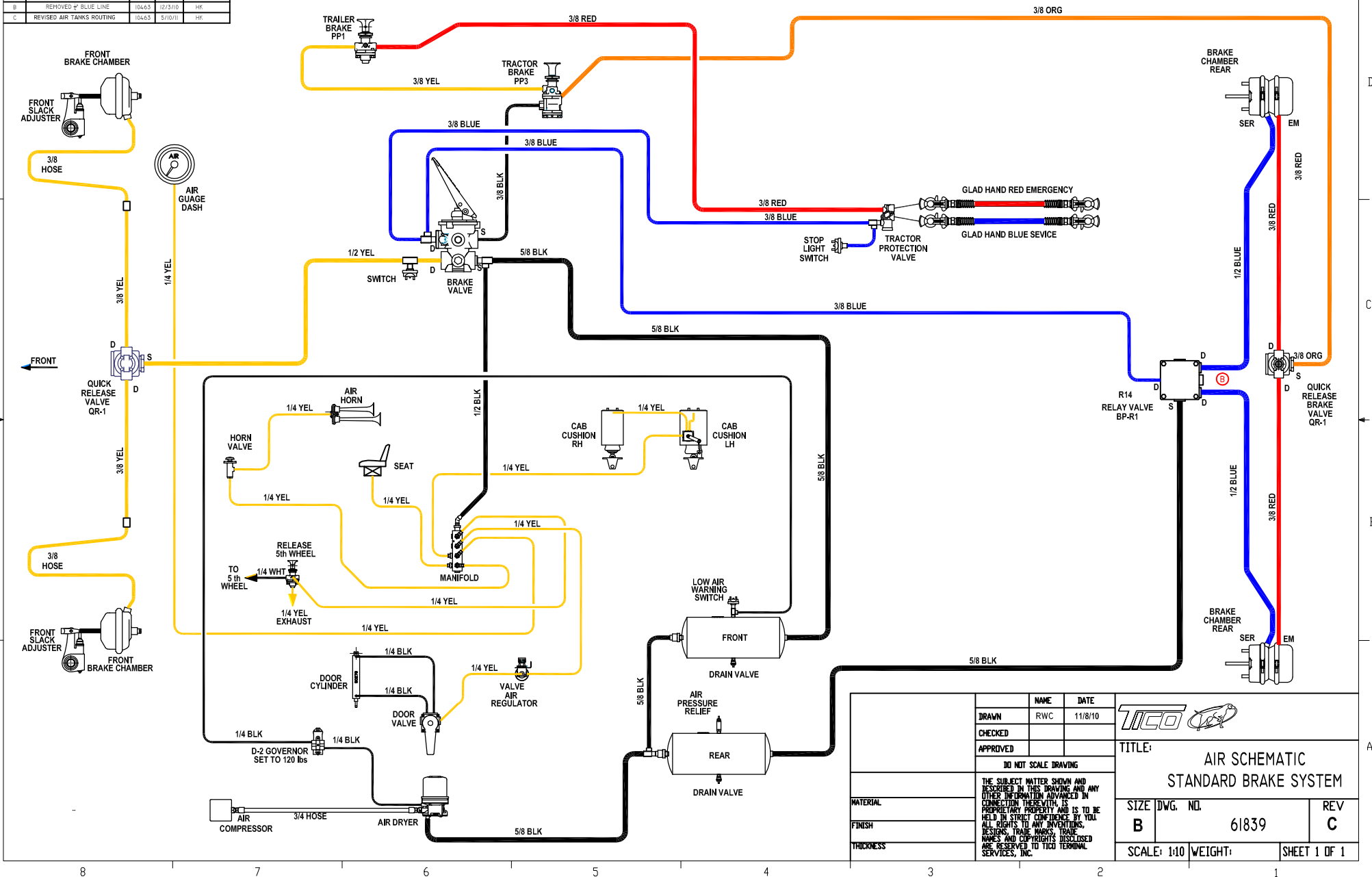

	NAME	DATE		<b>TITLE:</b> AIR SCHEMATIC STANDARD BRAKE SYSTEM	
DRAWN	RWC	11/8/10			
CHECKED					
APPROVED			<b>DO NOT SCALE DRAWING</b>		
MATERIAL	THE SUBJECT MATTER SHOWN AND DESCRIBED IN THIS DRAWING AND ANY OTHER INFORMATION ADVANCED IN CONNECTION THEREWITH IS PROPRIETARY PROPERTY AND IS TO BE HELD IN STRICT CONFIDENCE BY YOU. ALL RIGHTS TO ANY INVENTIONS, DESIGNS, TRADE MARKS, TRADE NAMES AND COPYRIGHTS DISCLOSED ARE RESERVED TO TICO TERMINAL SERVICES, INC.			<b>SIZE DWG. NO.</b> B 61839	<b>REV</b> C
FINISH				<b>SCALE:</b> 1:10	<b>WEIGHT:</b>
THICKNESS				<b>SHEET 1 OF 1</b>	