

8 7 6 5 4 3 2 1

D
C
B
A

D
C
B
A

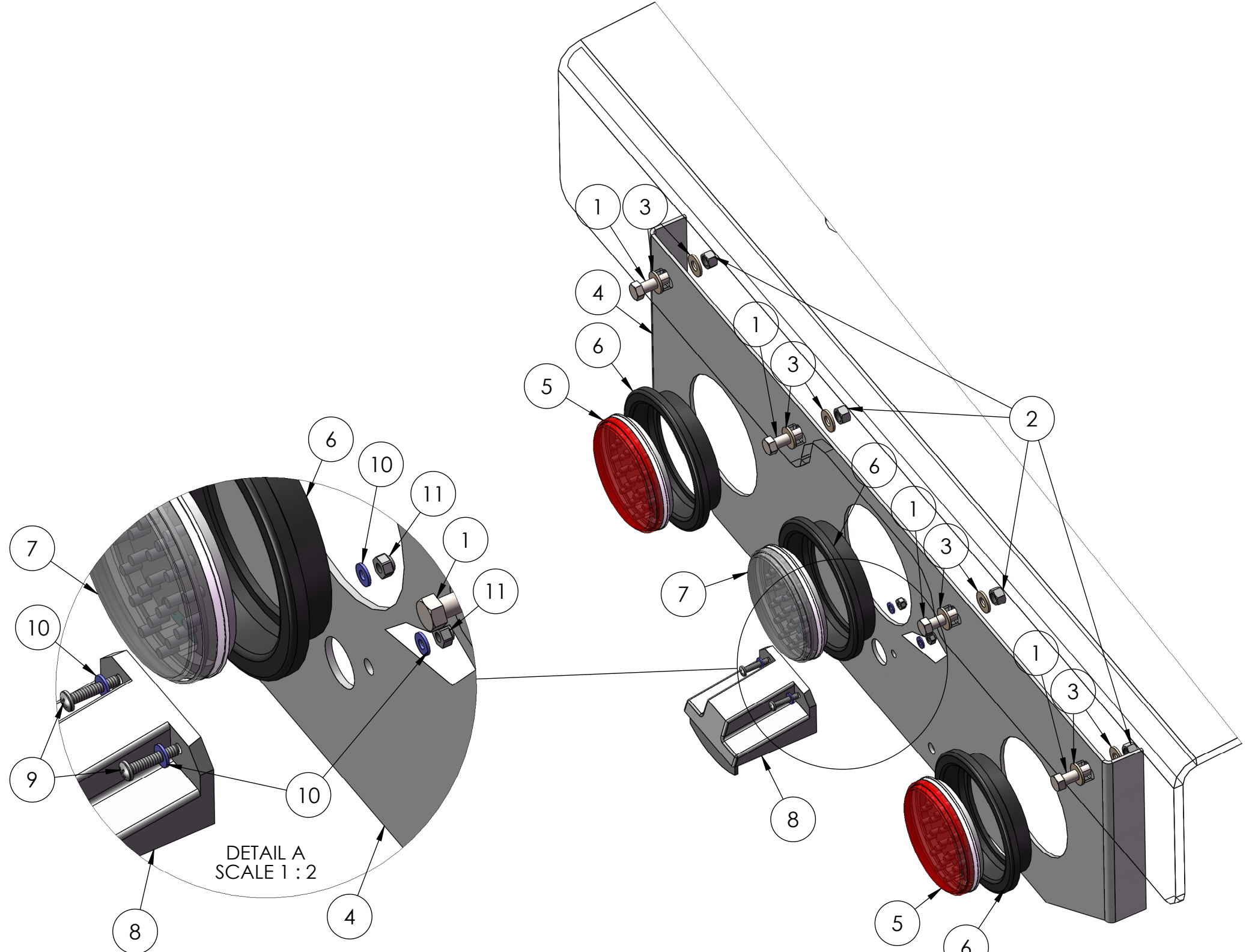

DETAIL A
SCALE 1 : 2

DIMENSIONS ARE IN INCHES TOLERANCES: DECIMAL: X.X ± 0.06 X.XX ± 0.03 X.XXX ± 0.005 ANGULAR: ± 0.5° FRACTIONAL ± 1/32"	DRAWN SMB	NAME SMB	DATE 4/9/15	TICO/TERMINAL SERVICE 66 CYPRESS RIDGE DR. RIDGELAND, SC 29936 (843) 717-2226
	CHECKED			
	APPROVED			
	DO NOT SCALE DRAWING			
INTERPRET GEOMETRIC TOLERANCING PER: ASME 14.5M-1994	THE SUBJECT MATTER SHOWN AND DESCRIBED IN THIS DRAWING AND ANY OTHER INFORMATION ADVANCED IN CONNECTION THEREWITH, IS PROPRIETARY PROPERTY AND IS TO BE HELD IN STRICT CONFIDENCE BY YOU. ALL RIGHTS TO ANY INVENTIONS, DESIGNS, TRADE MARKS, TRADE NAMES AND COPYRIGHTS DISCLOSED ARE RESERVED TO TICO TERMINAL SERVICES, INC.			TITLE: REAR TAIL LIGHTS, 3-RD TAIL LIGHTS, DOT-12V
FINISH	SIZE B	DWG. NO. 72352-A1	REV	SCALE: 1:10 WEIGHT: 119.2892 SHEET 1 OF 1

8 7 6 5 4 3 2 1

