

8 7 6 5 4 3 2 1

D  
C  
B  
A

D  
C  
B  
A

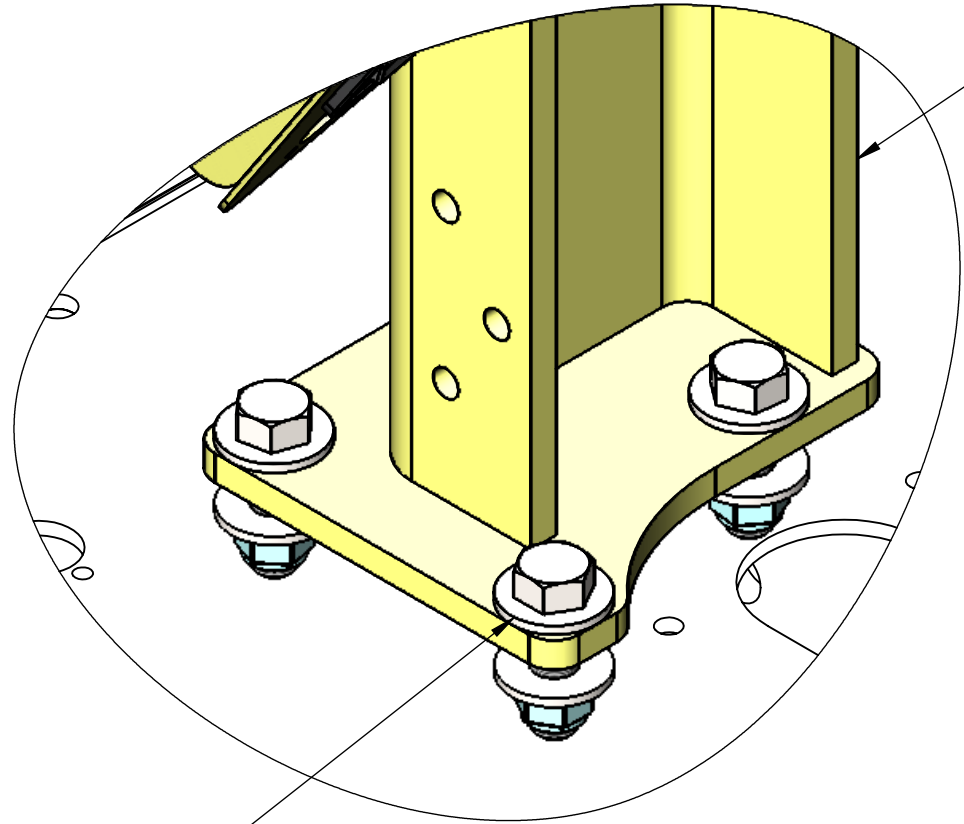

1 5 7 9  
2X

4 6 8  
2X

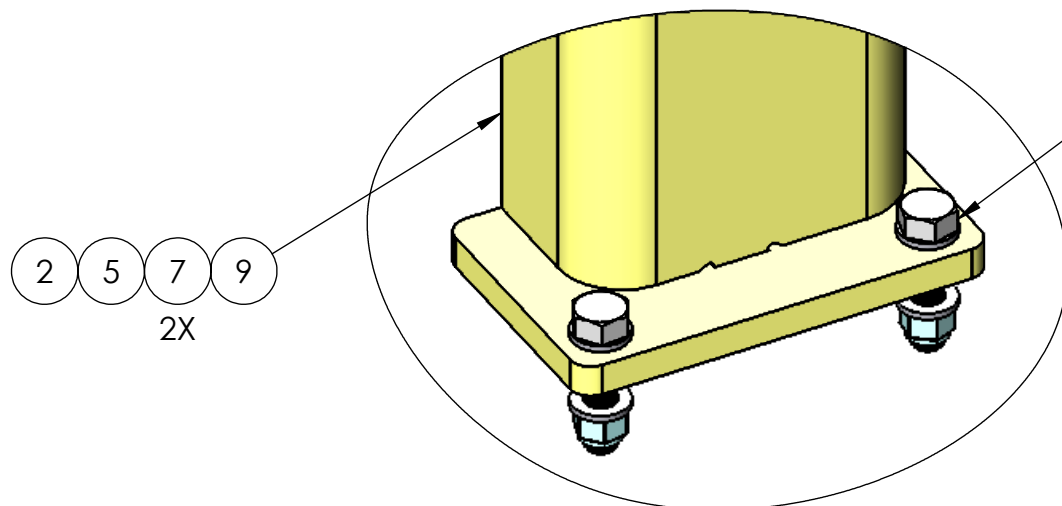

2 5 7 9  
2X

1 10

11

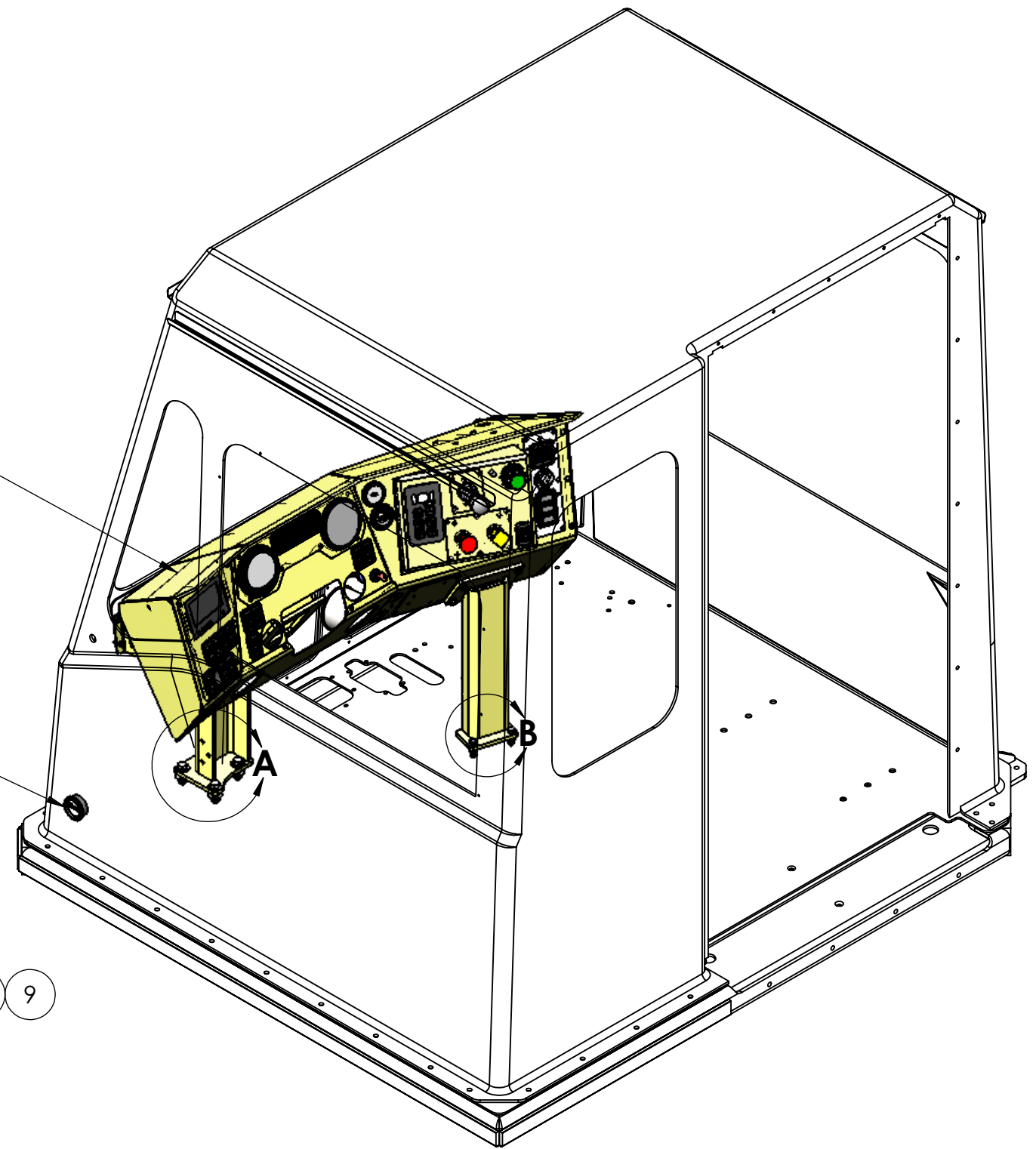

DIMENSIONS ARE IN INCHES TOLERANCES: DECIMAL: X.X ± 0.06 X.XX ± 0.03 X.XXX ± 0.005 ANGULAR: ± 0.5° FRACTIONAL ± 1/32"	DRAWN MPC	NAME MPC	DATE 01/02/2018	 TICO MANUFACTURING 66 CYPRESS RIDGE DR. RIDGELAND, SC 29936 (843) 717-2226	
	CHECKED ---	APPROVED ---	TITLE: ASSEMBLY, DASH PANEL		
	DO NOT SCALE DRAWING				SIZE <b>B</b>
	MATERIAL N/A	THE SUBJECT MATTER SHOWN AND DESCRIBED IN THIS DRAWING AND ANY OTHER INFORMATION ADVANCED IN CONNECTION THEREWITH, IS PROPRIETARY PROPERTY AND IS TO BE HELD IN STRICT CONFIDENCE BY YOU. ALL RIGHTS TO ANY INVENTIONS, DESIGNS, TRADE MARKS, TRADE NAMES AND COPYRIGHTS DISCLOSED ARE RESERVED TO TICO TERMINAL SERVICES, INC.			DWG. NO. 721866-C1
FINISH N/A	THICKNESS N/A	SCALE: 1:13	WEIGHT:	REV <b>C</b>	
			SHEET 1 OF 4		

8 7 6 5 4 3 2 1

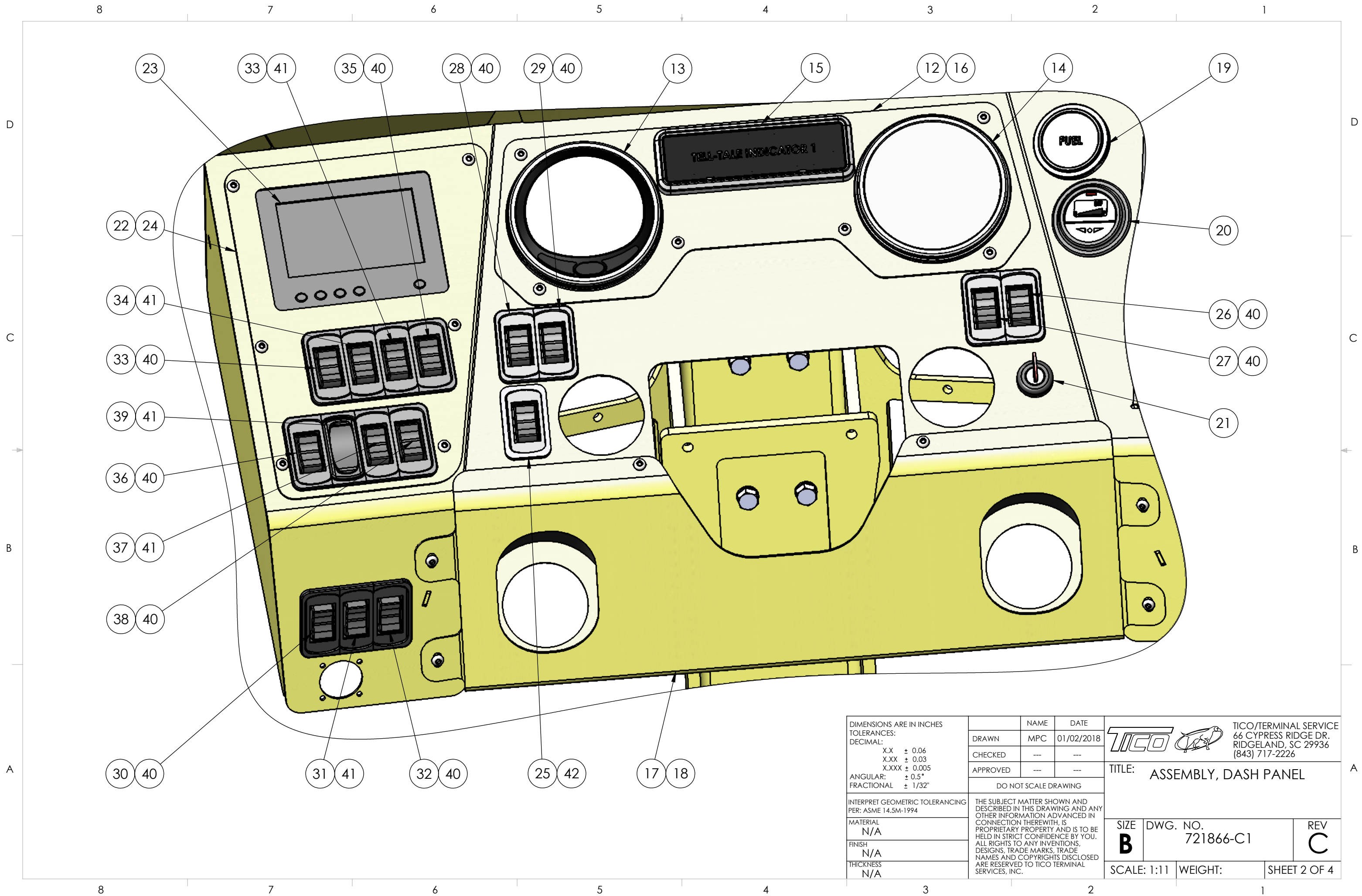

DIMENSIONS ARE IN INCHES TOLERANCES: DECIMAL: X.X ± 0.06 X.XX ± 0.03 X.XXX ± 0.005 ANGULAR: ± 0.5° FRACTIONAL ± 1/32"	NAME	DATE	 TICO/TERMINAL SERVICE 66 CYPRESS RIDGE DR. RIDGELAND, SC 29936 (843) 717-2226	
	DRAWN	MPC		01/02/2018
	CHECKED	---		---
	APPROVED	---		---
DO NOT SCALE DRAWING			TITLE: ASSEMBLY, DASH PANEL	
INTERPRET GEOMETRIC TOLERANCING PER: ASME 14.5M-1994	THE SUBJECT MATTER SHOWN AND DESCRIBED IN THIS DRAWING AND ANY OTHER INFORMATION ADVANCED IN CONNECTION THEREWITH, IS PROPRIETARY PROPERTY AND IS TO BE HELD IN STRICT CONFIDENCE BY YOU. ALL RIGHTS TO ANY INVENTIONS, DESIGNS, TRADE MARKS, TRADE NAMES AND COPYRIGHTS DISCLOSED ARE RESERVED TO TICO TERMINAL SERVICES, INC.		SIZE <b>B</b>	
MATERIAL N/A			DWG. NO. 721866-C1	
FINISH N/A			REV <b>C</b>	
THICKNESS N/A	SCALE: 1:11	WEIGHT:	SHEET 2 OF 4	

8 7 6 5 4 3 2 1

D  
C  
B  
A

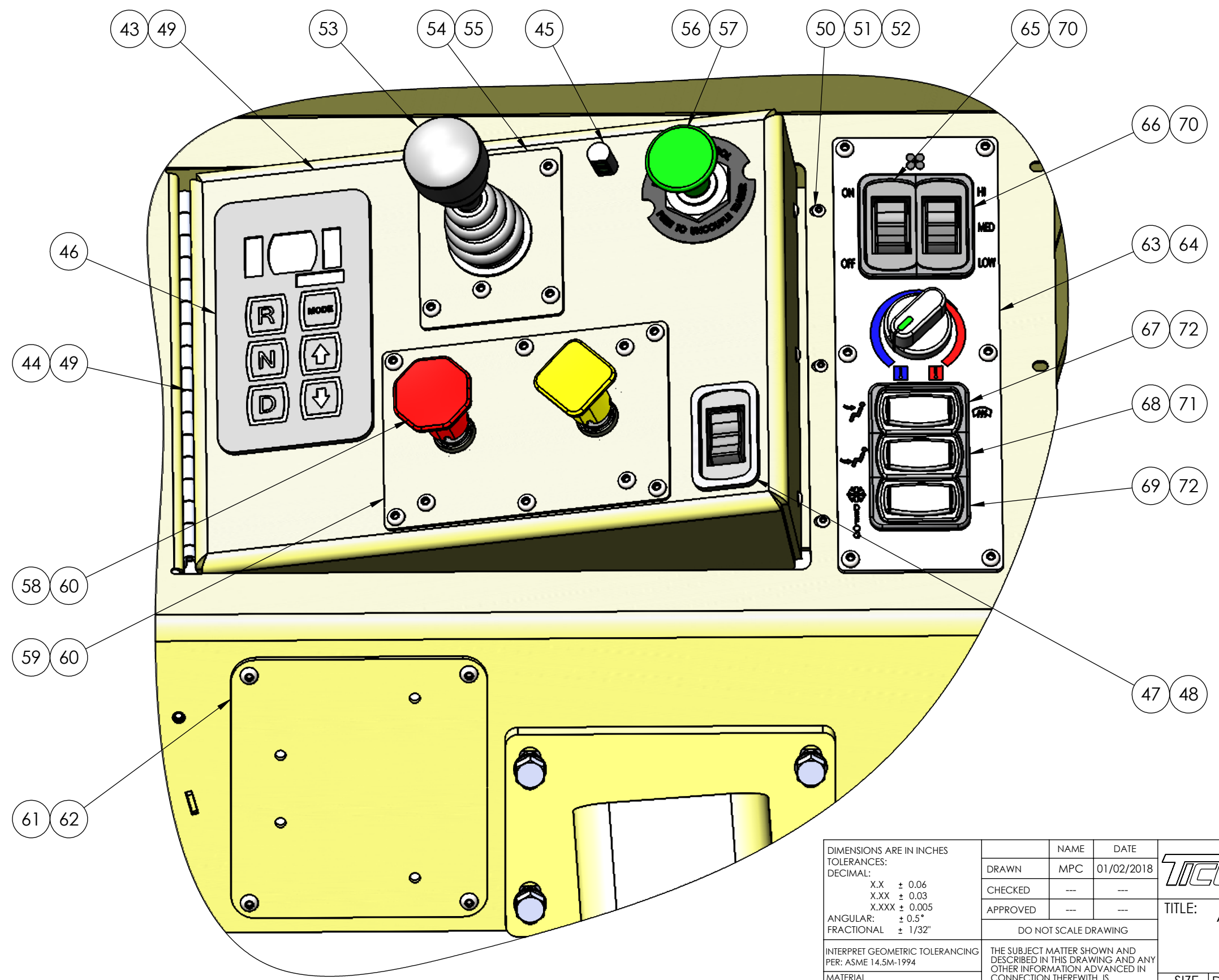

DIMENSIONS ARE IN INCHES TOLERANCES: DECIMAL: X.X ± 0.06 X.XX ± 0.03 X.XXX ± 0.005 ANGULAR: ± 0.5° FRACTIONAL ± 1/32"	NAME	DATE	 TICO/TERMINAL SERVICE 66 CYPRESS RIDGE DR. RIDGELAND, SC 29936 (843) 717-2226		
	DRAWN	MPC		01/02/2018	
	CHECKED	---		---	
	APPROVED	---		---	
INTERPRET GEOMETRIC TOLERANCING PER: ASME 14.5M-1994	DO NOT SCALE DRAWING		TITLE: ASSEMBLY, DASH PANEL		
MATERIAL N/A	THE SUBJECT MATTER SHOWN AND DESCRIBED IN THIS DRAWING AND ANY OTHER INFORMATION ADVANCED IN CONNECTION THEREWITH, IS PROPRIETARY PROPERTY AND IS TO BE HELD IN STRICT CONFIDENCE BY YOU. ALL RIGHTS TO ANY INVENTIONS, DESIGNS, TRADE MARKS, TRADE NAMES AND COPYRIGHTS DISCLOSED ARE RESERVED TO TICO TERMINAL SERVICES, INC.		SIZE <b>B</b>		
FINISH N/A			DWG. NO. 721866-C1	REV <b>C</b>	
THICKNESS N/A			SCALE: 1:11	WEIGHT:	SHEET 3 OF 4

8 7 6 5 4 3 2 1

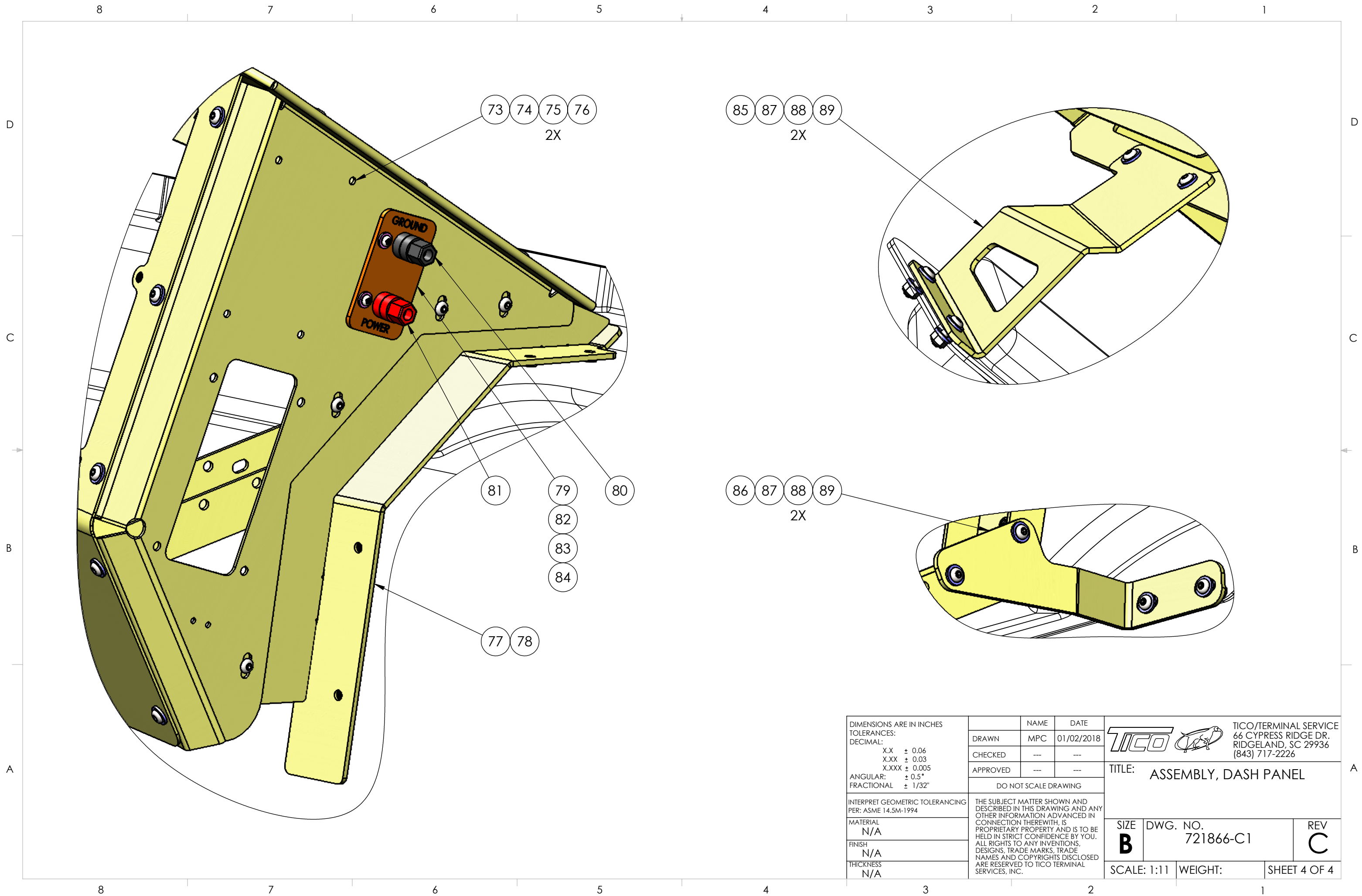

DIMENSIONS ARE IN INCHES TOLERANCES: DECIMAL: X.X ± 0.06 X.XX ± 0.03 X.XXX ± 0.005 ANGULAR: ± 0.5° FRACTIONAL ± 1/32"	NAME	DATE	 TICO/TERMINAL SERVICE 66 CYPRESS RIDGE DR. RIDGELAND, SC 29936 (843) 717-2226		
	DRAWN	MPC		01/02/2018	
	CHECKED	---		---	
	APPROVED	---		---	
INTERPRET GEOMETRIC TOLERANCING PER: ASME 14.5M-1994	DO NOT SCALE DRAWING		TITLE: ASSEMBLY, DASH PANEL		
MATERIAL N/A	THE SUBJECT MATTER SHOWN AND DESCRIBED IN THIS DRAWING AND ANY OTHER INFORMATION ADVANCED IN CONNECTION THEREWITH, IS PROPRIETARY PROPERTY AND IS TO BE HELD IN STRICT CONFIDENCE BY YOU. ALL RIGHTS TO ANY INVENTIONS, DESIGNS, TRADE MARKS, TRADE NAMES AND COPYRIGHTS DISCLOSED ARE RESERVED TO TICO TERMINAL SERVICES, INC.		SIZE <b>B</b>		
FINISH N/A			DWG. NO. 721866-C1	REV <b>C</b>	
THICKNESS N/A			SCALE: 1:11	WEIGHT:	SHEET 4 OF 4



TICO PRO-SPOTTER					
			ASSEMBLY, DASH PANEL	721866	
ITEM	PART #	QTY	DESCRIPTION	NOTE	
25	910369	1	SWITCH, DIMMER/RHEOSTAT		
26	910356	1	SWITCH, HEADLIGHTS/PARKLIGHTS		
27	910389	1	SWITCH, WIPER/WASHER, INTERMITTENT		
28	910566	1	SWITCH, DOLLY MASTER, RAISE/LOWER (IF 37A IS USED)	OPTION	
29	910565	1	SWITCH, MAGNET, AIR RELEASE (IF 38A IS USED)	OPTION	
30	910363	1	SWITCH, ABS DIAGNOSTICS	OPTION	
31	910367	1	SWITCH, ENGINE, INCREMENT/DECREMENT	OPTION	
32	910362	1	SWITCH, ENGINE DIAGNOSTICS	OPTION	
33	910357	2	SWITCH, WORKLIGHTS		
34	910358	1	SWITCH, AUXILIARY WORKLIGHTS		
35	910360	1	SWITCH, BEACON, STROBE	OPTION	
36	910359	1	SWITCH, MIRROR, DEFROST	OPTION	
37A	910365	1	SWITCH, MIRROR, DIRECTION (LEFT)	OPTION	
37B	910566	1	SWITCH, DOLLY MASTER, RAISE/LOWER (IF 37A IS NOT USED)	OPTION	
38A	910365	1	SWITCH, MIRROR, DIRECTION (RIGHT)	OPTION	
38B	910565	1	SWITCH, MAGNET, AIR RELEASE (IF 38A IS NOT USED)	OPTION	
39	910373	REF	PLUG, PANEL (FOR ANY BEZEL NOT USED)		
40	910372	10	BEZEL, MOUNTING, END		
41	910371	5	BEZEL, MOUNTING, CENTER		
42	90946	1	BEZEL, MOUNTING, SINGLE		
43	121936	1	PIVOT BOX, DASH, STATIONARY, RIGHT-HAND		
44	200354	1	HINGE, PIVOT BOX		
45	910454	1	LIGHT, PANEL, LED, INSTRUMENT		
46	62192	1	SHIFTER, TRANSMISSION, PUSH BUTTON, GENERATION V		
47	910368	1	SWITCH, DOOR, OPEN/CLOSE		
48	90946	1	BEZEL, MOUNTING, SINGLE		
49	800410	8	SCREW, SOCKET CAP, BUTTON HEAD, STAINLESS STEEL, 10-32 X 1/2 LC		
50	121977	1	MOUNTING BRACKET, DASH, PIVOT BOX		
51	800426	6	SCREW, SOCKET CAP, BUTTON HEAD, STAINLESS STEEL, #6-32 X 5/8 LC		
52	800427	6	LOCKNUT, NYLON, STAINLESS STEEL, #6-32		
53	30373	1	JOYSTICK, 5TH WHEEL CONTROL, ELECTRIC, 100 MM		
54	200356	1	PLATE, BOOM CONTROL, DASH PANEL (JOYSTICK)		
55	800410	6	SCREW, SOCKET CAP, BUTTON HEAD, STAINLESS STEEL, 10-32 X 1/2 LC		
NOT SHOWN	620756	1	HARNESS, WIRE, BOOM ELEVATION, JOYSTICK		
56	90060	1	VALVE, UNLATCH, 5TH WHEEL		
57	90647	1	DECAL, UNLATCH, 5TH WHEEL		
NOT SHOWN	40858	1	FITTING, PLUG, BRASS, 1/8 NPT		
NOT SHOWN	40860	2	FITTING, ELBOW, 90°, BRASS, SWIVEL, 1/4 TUBE X 1/8 NPT		
NOT SHOWN	40886	1	FITTING, STRAIGHT, BRASS, 1/4 TUBE X 1/8 NPT		
REV	DATE	BY		SHEET	2
C	01/02/2018	MPC		OF	3

TICO MANUFACTURING - RIDGELAND, SC 29936

TICO PRO-SPOTTER					
			ASSEMBLY, DASH PANEL	721866	
ITEM	PART #	QTY	DESCRIPTION	NOTE	
58	40570	1	BRAKE VALVE, MV3		
59	121938	1	PLATE, BRAKE VALVE, MV3, DASH PANEL		
60	800410	10	SCREW, SOCKET CAP, BUTTON HEAD, STAINLESS STEEL, 10-32 X 1/2 LC		
NOT SHOWN	40846	4	FITTING, STRAIGHT, BRASS, 3/8 TUBE X 1/4 NPT		
NOT SHOWN	40883	1	FITTING, STRAIGHT, BRASS, 1/4 TUBE X 1/4 NPT		
61	121933	1	PANEL, DASH, LOWER RIGHT		
62	800410	4	SCREW, SOCKET CAP, BUTTON HEAD, STAINLESS STEEL, 10-32 X 1/2 LC		
63	920358	1	PANEL, HEATER/AC CONTROLS		
64	800410	10	SCREW, SOCKET CAP, BUTTON HEAD, STAINLESS STEEL, 10-32 X 1/2 LC		
65	910494	1	SWITCH, FAN, ON/OFF (POSITION 1)		
66	910495	1	SWITCH, FAN SPEED, HI/MED/LOW (POSITION 2)		
67	910492	1	SWITCH, DEFROST/VENT (POSITION 3)		
68	910492	1	SWITCH, FLOOR (POSITION 4)		
69	910492	1	SWITCH, AC (POSITION 5)	OPTION	
NOT SHOWN	910493	REF	SWITCH, BLANK (FOR ANY BEZEL NOT USED)		
70	910372	2	BEZEL, END (TOP)		
71	910501	1	BEZEL, CENTER		
72	910502	2	BEZEL, END (BOTTOM)		
73	121930	1	PLATE, DASH, RIGHT-HAND		
74	80218	8	SCREW, SOCKET CAP, BUTTON HEAD, STAINLESS STEEL, 10-32 X 3/4 LC		
75	80232	16	WASHER, FLAT, STAINLESS STEEL, #10		
76	800424	8	LOCKNUT, NYLON, STAINLESS STEEL, #10-32		
77	122367	1	BRACKET, HVAC COVER		
78	80218	4	SCREW, SOCKET CAP, BUTTON HEAD, STAINLESS STEEL, 10-32 X 3/4 LC		
79	121934	1	PLATE, ELECTRICAL SUPPLY		
80	90585	1	TERMINAL, NEGATIVE, BINDING POST, DC, 12 VOLT		
81	90586	1	TERMINAL, POSITIVE, BINDING POST, DC, 12 VOLT		
82	800442	4	SCREW, PAN HEAD, STAINLESS STEEL, 6-32 X 1/2 LONG		
83	80230	4	WASHER, FLAT, STAINLESS STEEL, #6		
84	800427	4	LOCKNUT, NYLON, STAINLESS STEEL, #6-32		
85	122370	1	BRACKET, DEFROSTER DUCT (LEFT-HAND)		
86	122371	1	BRACKET, DEFROSTER DUCT (RIGHT-HAND)		
87	80218	8	SCREW, SOCKET CAP, BUTTON HEAD, STAINLESS STEEL, 10-32 X 3/4 LC		
88	80232	16	WASHER, FLAT, STAINLESS STEEL, #10		
89	800424	8	LOCKNUT, NYLON, STAINLESS STEEL, #10-32		
REV	DATE	BY	SHEET		3
C	01/02/2018	MPC	OF		3

TICO MANUFACTURING - RIDGELAND, SC 29936