

PAGE 1 : OVERVIEW & DASH SUPPORTS
PAGE 2 : MAIN DASH COMPONENTS
PAGE 3 : PIVOT BOX & BRACKETS
PAGE 4 : DEFROSTER BRACKETS
PAGE 5-7 : PARTS LIST

DIMENSIONS ARE IN INCHES TOLERANCES: DECIMAL: X.X ± 0.04 X.XX ± 0.03 X.XXX ± 0.005 ANGULAR: ± 0.5° FRACTIONAL: ± 1/32"		NAME MPC	DATE 01/27/2018	TICO/TERMINAL SERVICE 44 CYPRESS RIDGE DR. RIDGELAND, SC 29936 (843) 717-2226
INTERPRET GEOMETRIC TOLERANCING PER: ASME Y14.5M-1994		CHECKED ---	APPROVED ---	
MATERIAL N/A		DO NOT SCALE DRAWING		SIZE D
FINISH N/A		THE SUBJECT MATTER SHOWN AND DESCRIBED IN THIS DRAWING AND ANY OTHER INFORMATION ADVANCED IN CONNECTION THEREWITH IS PROPRIETARY PROPERTY AND IS TO BE HELD IN STRICT CONFIDENCE BY YOU. ALL RIGHTS TO ANY INVENTIONS, DESIGNS, TRADE MARKS, TRADE NAMES AND COPYRIGHTS DISCLOSED ARE RESERVED TO TICO/TERMINAL SERVICES, INC.		DWG. NO. 721819-F1
THICKNESS N/A		SCALE: 1:7		REV F
		WEIGHT:		SHEET 1 OF 4

721819-F1

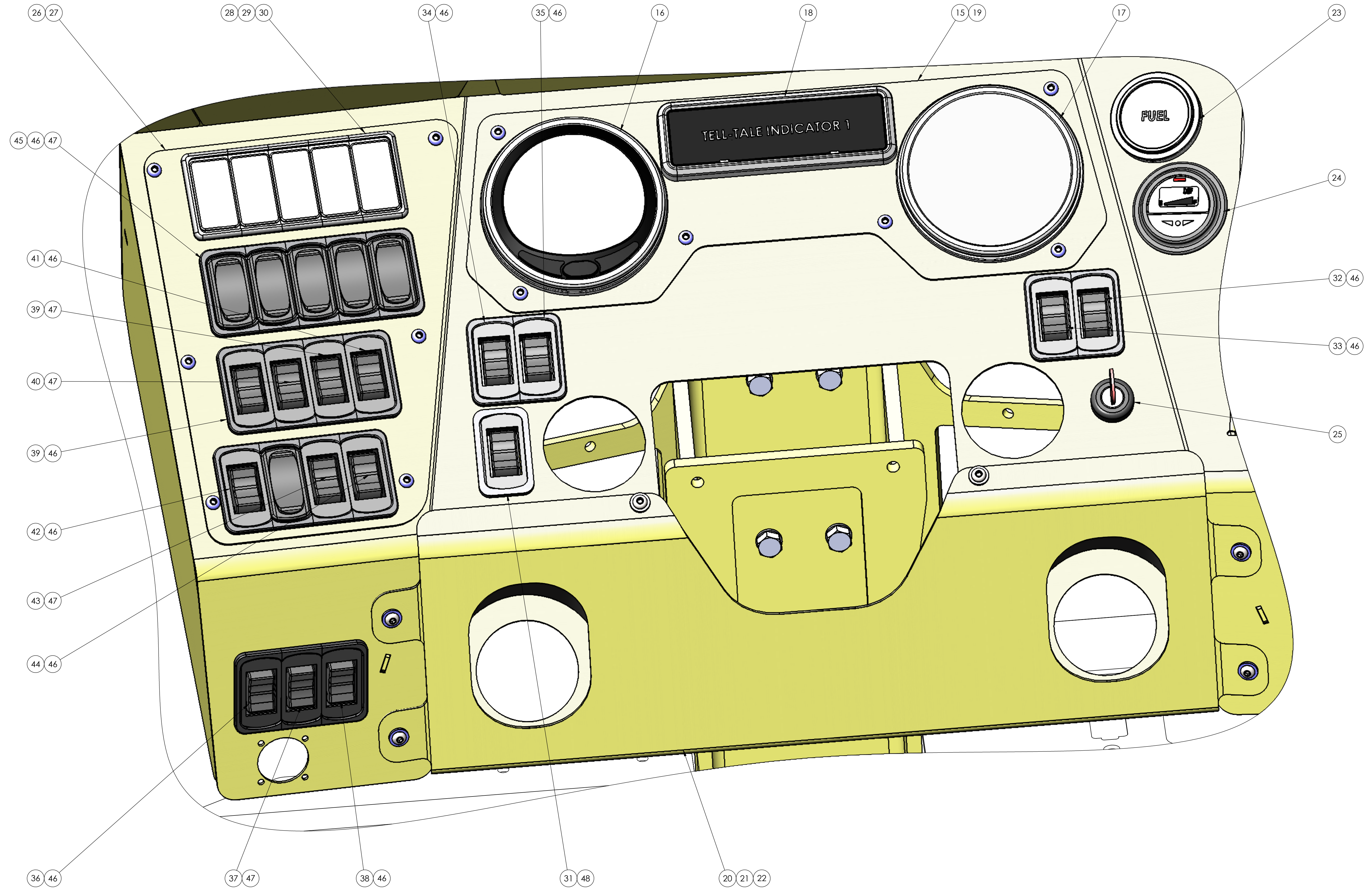

DIMENSIONS ARE IN INCHES TOLERANCES: DECIMAL: XX ± 0.04 XXX ± 0.03 X.XXX ± 0.005 ANGULAR: ± 0.5° FRACTIONAL: ± 1/32"		NAME MPC	DATE 01/27/2018	 TICO/TERMINAL SERVICE 44 CYPRESS RIDGE DR. RIDGELAND, SC 29936 (843) 717-2226
INTERPRET GEOMETRIC TOLERANCING PER: ASME Y14.5M-1994		CHECKED ---	APPROVED ---	
MATERIAL N/A		DO NOT SCALE DRAWING THE SUBJECT MATTER SHOWN AND DESCRIBED IN THIS DRAWING AND ANY OTHER INFORMATION ADVANCED IN CONNECTION THEREWITH IS PROPRIETARY PROPERTY AND IS TO BE HELD IN STRICT CONFIDENCE BY YOU. ALL RIGHTS TO ANY INVENTIONS, DESIGNS, TRADE MARKS, TRADE NAMES AND COPYRIGHTS DISCLOSED ARE RESERVED TO TICO/TERMINAL SERVICES, INC.		
FINISH N/A	THICKNESS N/A	TITLE: ASSEMBLY, DASH PANEL SIZE: D DWG. NO. 721819-F1 SCALE: 1:7 WEIGHT: SHEET 2 OF 4		

721819-F1

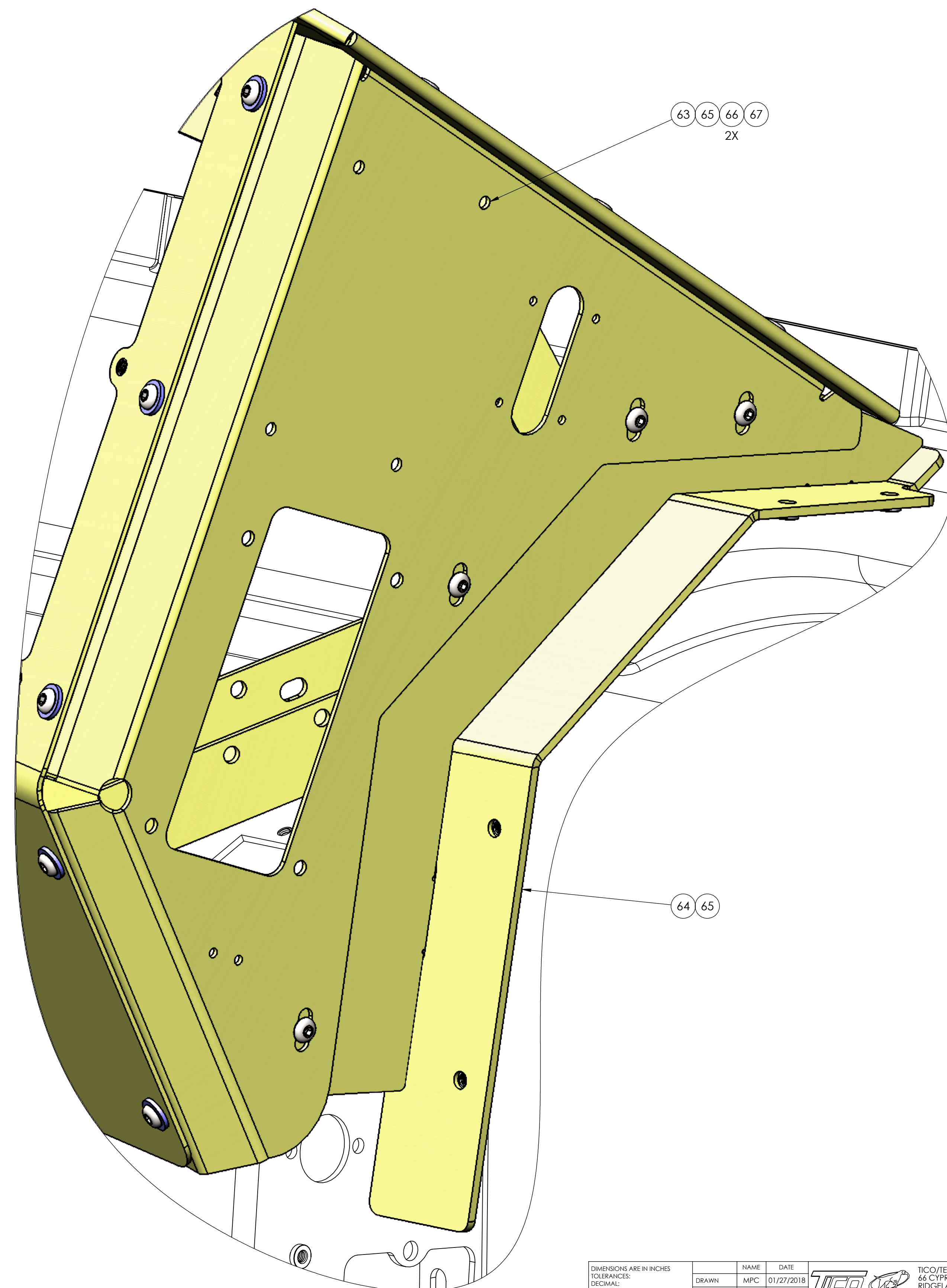
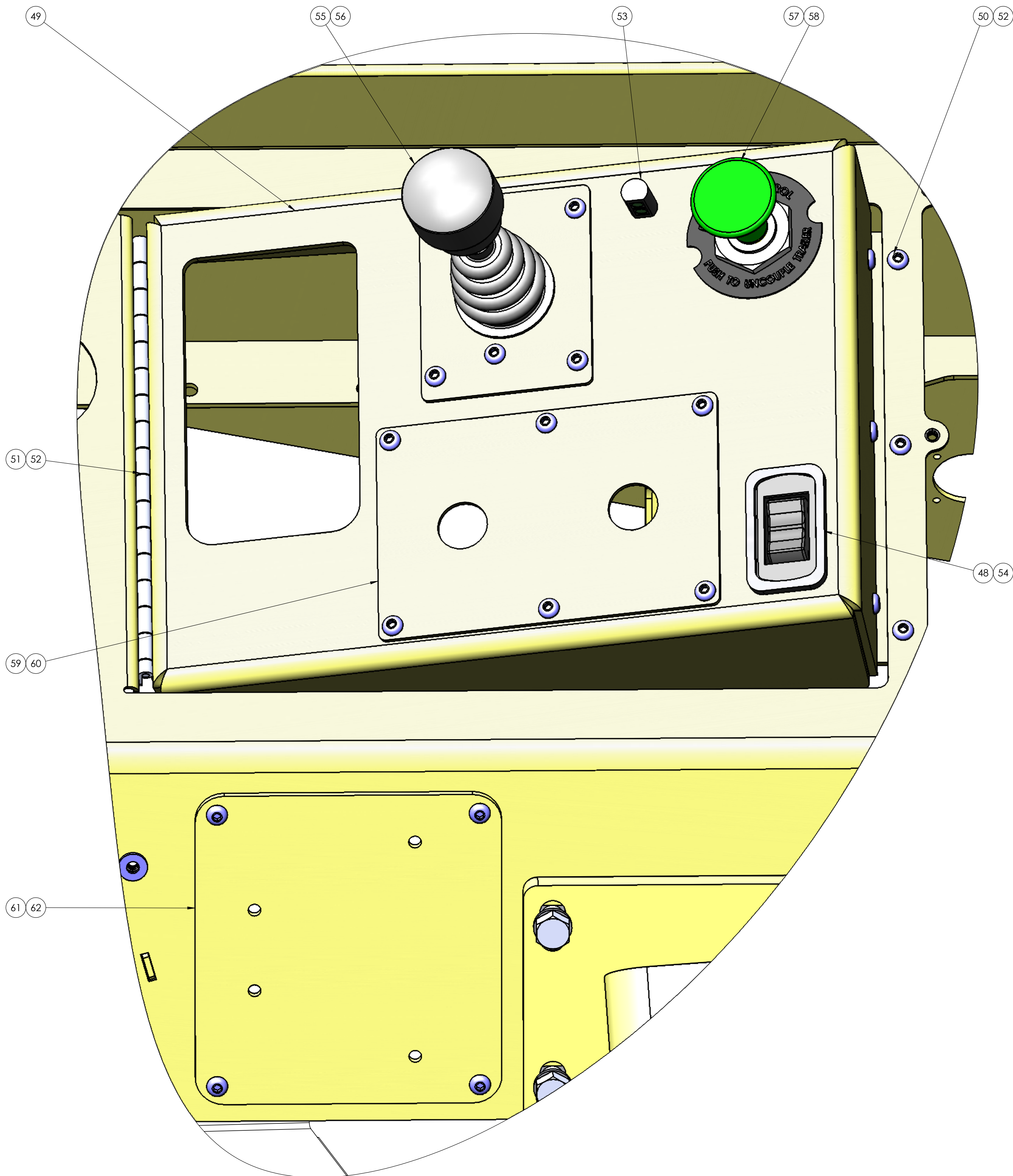

DIMENSIONS ARE IN INCHES TOLERANCES: DECIMAL: X.X ± 0.04 X.XX ± 0.03 X.XXX ± 0.005 ANGULAR: ± 0.5° FRACTIONAL: ± 1/32"		NAME MPC	DATE 01/27/2018	 TICO/TERMINAL SERVICE 64 CYPRESS RIDGE DR. RIDGLAND, SC 29936 (843) 717-2226
INTERPRET GEOMETRIC TOLERANCING PER: ASME Y14.5M-1994		CHECKED ---	APPROVED ---	
MATERIAL N/A		DO NOT SCALE DRAWING		SIZE DWG. NO. REV D 721819-F1 F
FINISH N/A		SCALE: 1:7 WEIGHT:		
THICKNESS N/A		THE SUBJECT MATTER SHOWN AND DESCRIBED IN THIS DRAWING AND ANY OTHER INFORMATION ADVANCED IN CONNECTION THEREWITH IS PROPRIETARY PROPERTY AND IS TO BE HELD IN STRICT CONFIDENCE BY YOU. ALL RIGHTS TO ANY INVENTIONS, DESIGNS, TRADE MARKS, TRADE NAMES AND COPYRIGHTS DISCLOSED ARE RESERVED TO TICO/TERMINAL SERVICES, INC.		

D 721819-F1

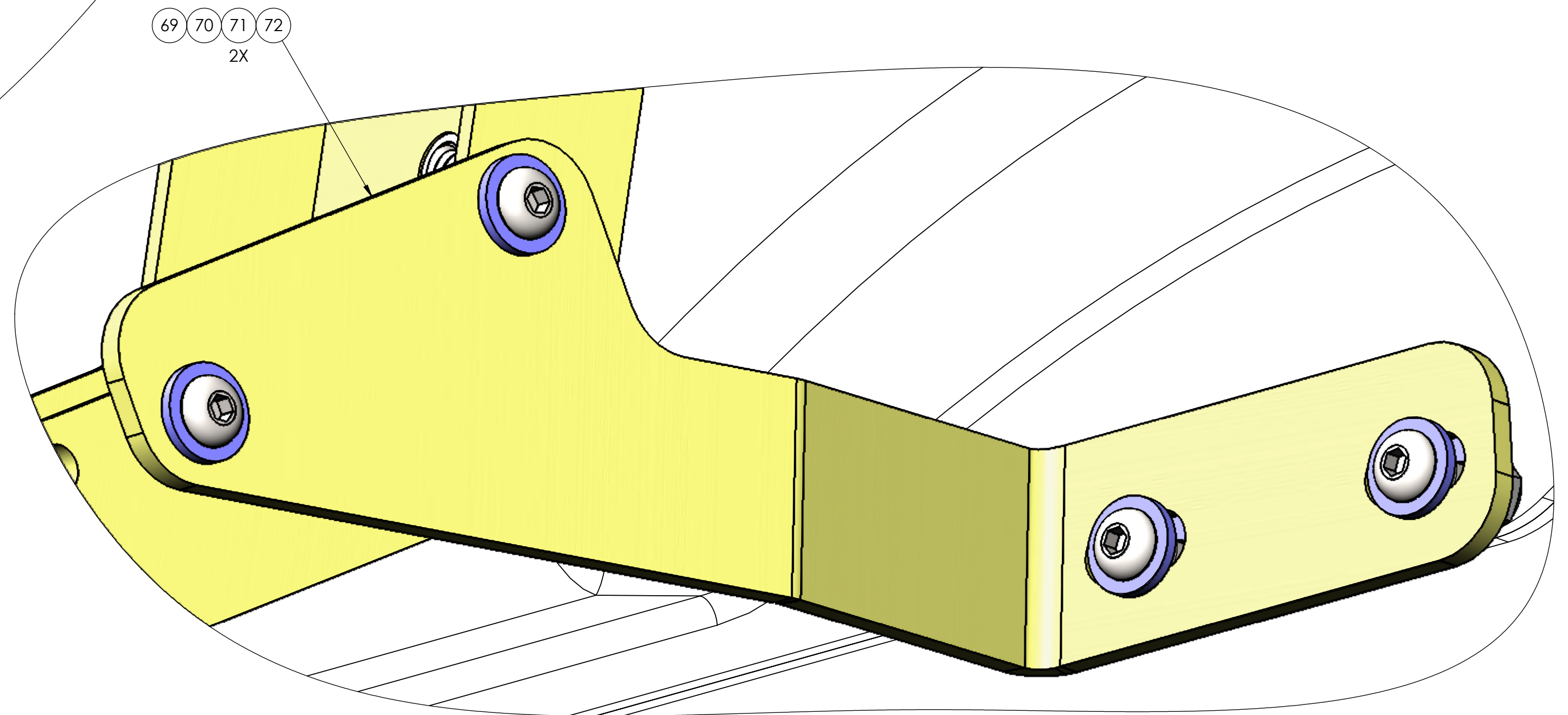
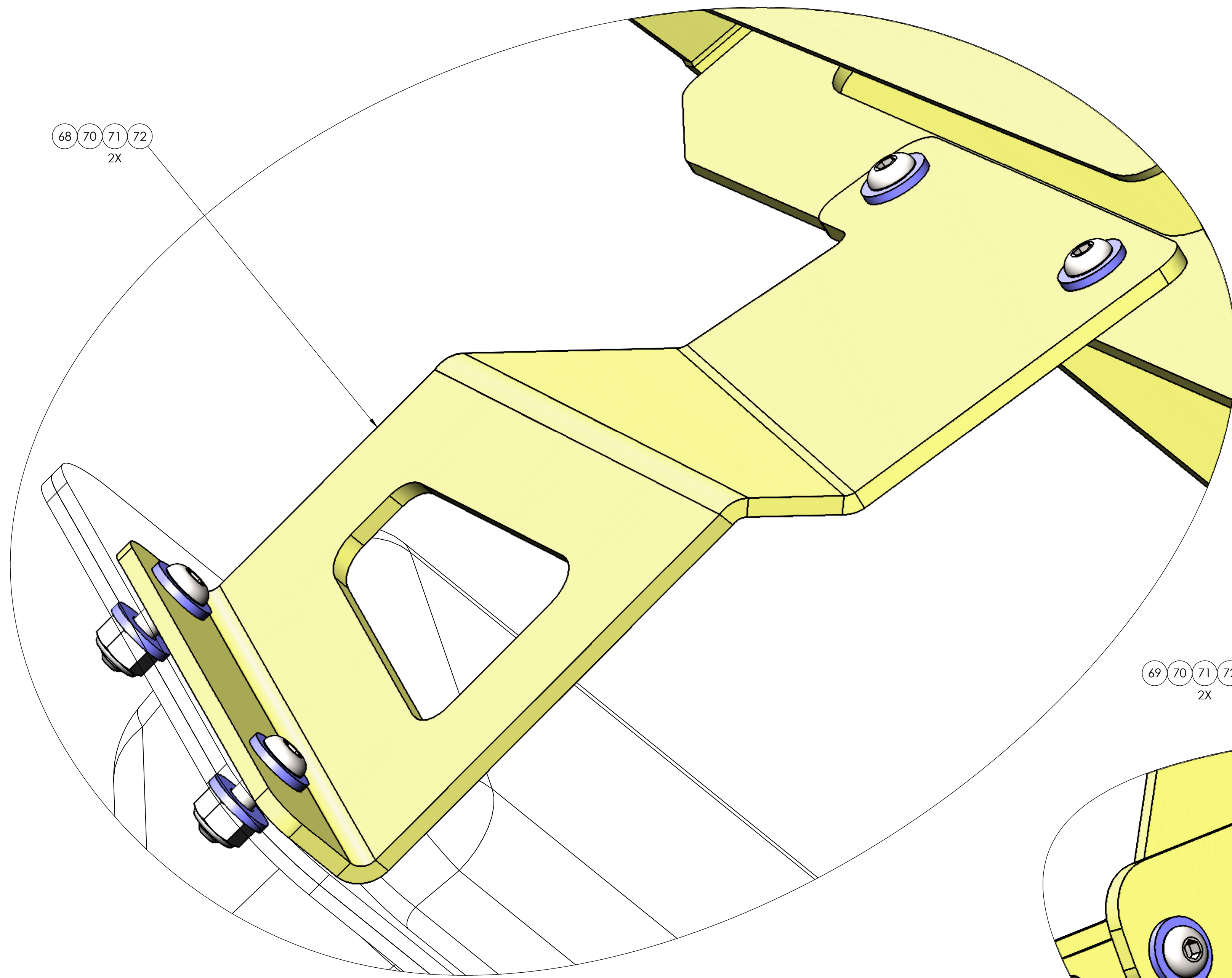

DIMENSIONS ARE IN INCHES TOLERANCES: DECIMAL: X.X ± 0.04 X.XX ± 0.03 X.XXX ± 0.005 ANGULAR: ± 0.5° FRACTIONAL: ± 1/32"		NAME MPC	DATE 01/27/2018	 TICO/TERMINAL SERVICE 64 CYPRESS RIDGE DR. RIDGELAND, SC 29936 (843) 717-2226
INTERPRET GEOMETRIC TOLERANCING PER: ASME Y14.5M-1994		CHECKED ---	APPROVED ---	
MATERIAL N/A		DO NOT SCALE DRAWING		SIZE D
FINISH N/A		THE SUBJECT MATTER SHOWN AND DESCRIBED IN THIS DRAWING AND ANY OTHER INFORMATION ADVANCED IN CONNECTION HEREWITH IS PROPRIETARY PROPERTY AND IS TO BE HELD IN STRICT CONFIDENCE BY YOU. ALL RIGHTS TO ANY INVENTIONS, DESIGNS, TRADE MARKS, TRADE NAMES AND COPYRIGHTS DISCLOSED ARE RESERVED TO TICO/TERMINAL SERVICES, INC.		DWG. NO. 721819-F1
THICKNESS N/A		SCALE: 1:7		REV F
		WEIGHT:		SHEET 4 OF 4

D 721819-F1

TICO PRO-SPOTTER					
			ASSEMBLY, DASH PANEL	721819	
ITEM	PART #	QTY	DESCRIPTION	NOTE	
26	122615	1	PANEL, DASH, STANDARD (LEFT-HAND)		
27	800410	6	SCREW, SOCKET CAP, BUTTON HEAD, STAINLESS STEEL, 10-32 X 1/2 LC		
28	90734	2	BEZEL, END, V-SERIES (INDICATOR LAMPS)		
29	90735	3	BEZEL, MIDDLE, V-SERIES (INDICATOR LAMPS)		
30	90733	5	PLUG, BEZEL, V-SERIES (INDICATOR PANEL)		
NOT SHOWN	620806	1	HARNES, WIRE, LEFT-HAND DASH PANEL, SWITCHES, 2017 CAB		
31	910369	1	SWITCH, DIMMER/RHEOSTAT	OPTION	
32	910356	1	SWITCH, HEADLIGHTS/PARKLIGHTS	OPTION	
33	910389	1	SWITCH, WIPER/WASHER, INTERMITTENT		
34	910566	1	SWITCH, DOLLY MASTER, RAISE/LOWER (IF 37A IS USED)	OPTION	
35	910565	1	SWITCH, MAGNET, AIR RELEASE (IF 38A IS USED)	OPTION	
36	910363	1	SWITCH, ABS DIAGNOSTICS	OPTION	
37	910367	1	SWITCH, ENGINE, INCREMENT/DECREMENT	OPTION	
38	910362	1	SWITCH, ENGINE DIAGNOSTICS	OPTION	
39	910357	2	SWITCH, WORKLIGHTS		
40	910358	1	SWITCH, AUXILIARY WORKLIGHTS		
41	910360	1	SWITCH, BEACON, STROBE	OPTION	
42	910359	1	SWITCH, MIRROR, DEFROST	OPTION	
43A	910365	1	SWITCH, MIRROR, DIRECTION (LEFT)	OPTION	
43B	910566	1	SWITCH, DOLLY MASTER, RAISE/LOWER (IF 37A IS NOT USED)	OPTION	
44A	910365	1	SWITCH, MIRROR, DIRECTION (RIGHT)	OPTION	
44B	910565	1	SWITCH, MAGNET, AIR RELEASE (IF 38A IS NOT USED)	OPTION	
45	910373	REF	PLUG, PANEL (FOR ANY BEZEL NOT USED)		
46	910372	12	BEZEL, MOUNTING, END		
47	910371	8	BEZEL, MOUNTING, CENTER		
48	90946	2	BEZEL, MOUNTING, SINGLE		
49	121936	1	PIVOT BOX, DASH, STATIONARY, RIGHT-HAND		
50	121977	1	MOUNTING BRACKET, DASH, PIVOT BOX		
51	200354	1	HINGE, PIVOT BOX		
52	800410	14	SCREW, SOCKET CAP, BUTTON HEAD, STAINLESS STEEL, 10-32 X 1/2 LC		
53	910454	1	LIGHT, PANEL, LED, INSTRUMENT		
54	910368	1	SWITCH, DOOR, OPEN/CLOSE		
55	200396	1	ASSEMBLY, JOYSTICK, DASH PANEL (BOOM CONTROLS)		
NO BALLOON	30373	1	JOYSTICK, 5TH WHEEL CONTROL, ELECTRIC, 100 MM		
NO BALLOON	200356	1	PLATE, BOOM CONTROL, DASH PANEL (JOYSTICK)		
NO BALLOON	800410	2	SCREW, SOCKET CAP, BUTTON HEAD, STAINLESS STEEL, 10-32 X 1/2 LC		
56	800410	4	SCREW, SOCKET CAP, BUTTON HEAD, STAINLESS STEEL, 10-32 X 1/2 LC		
NOT SHOWN	620756	1	HARNES, WIRE, BOOM ELEVATION, JOYSTICK		
REV	DATE	BY		SHEET	2
F	01/27/2018	MPC		OF	3

TICO MANUFACTURING - RIDGELAND, SC 29936

