

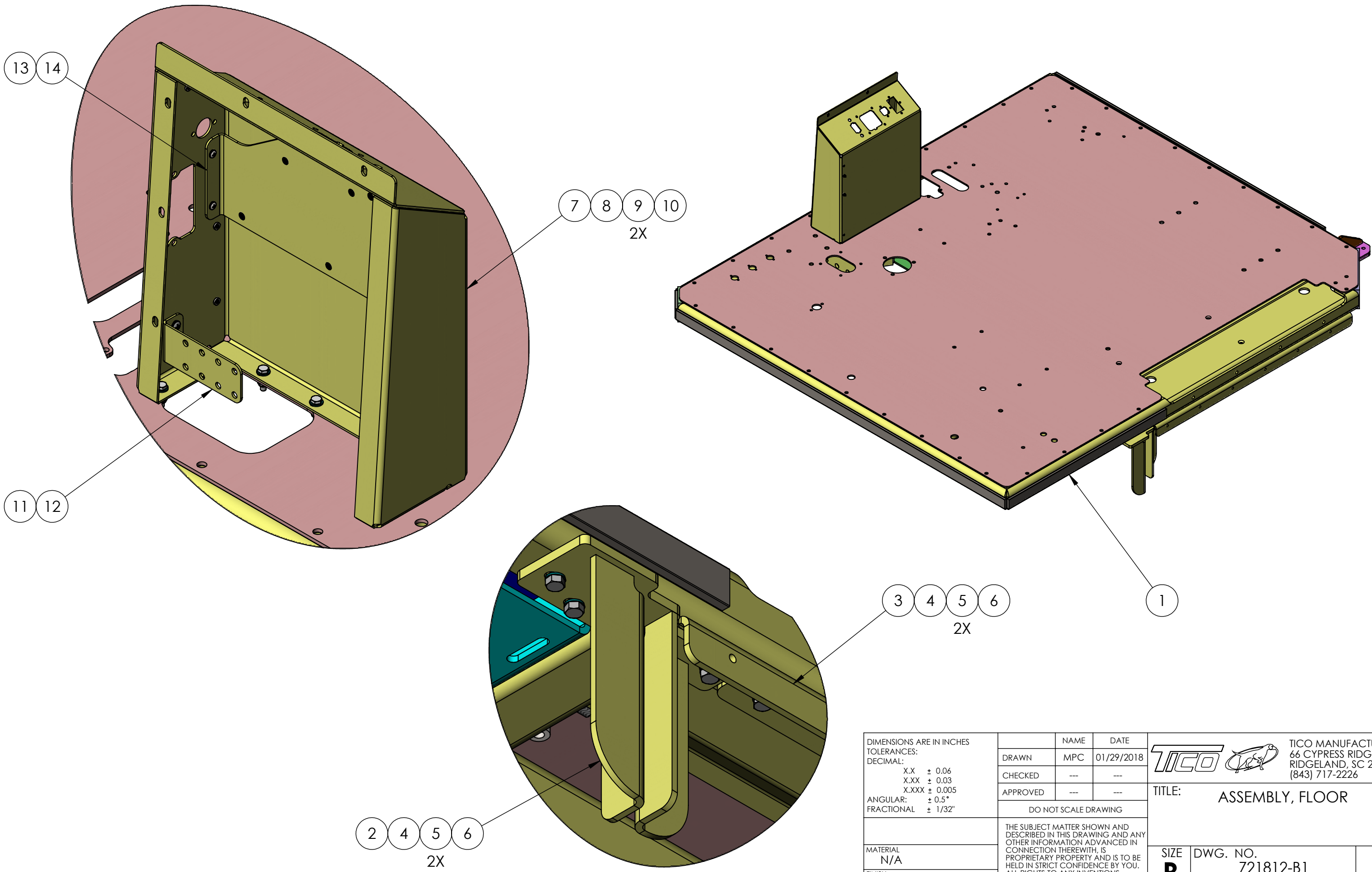

8 7 6 5 4 3 2 1

D
C
B
A

D
C
B
A



DIMENSIONS ARE IN INCHES		NAME	DATE	 TICO MANUFACTURING 66 CYPRESS RIDGE DR. RIDGELAND, SC 29936 (843) 717-2226	
TOLERANCES:		DRAWN	MPC		01/29/2018
DECIMAL:		CHECKED	---		---
X.X ± 0.06		APPROVED	---	---	
X.XX ± 0.03		DO NOT SCALE DRAWING			
X.XXX ± 0.005		THE SUBJECT MATTER SHOWN AND DESCRIBED IN THIS DRAWING AND ANY OTHER INFORMATION ADVANCED IN CONNECTION THEREWITH, IS PROPRIETARY PROPERTY AND IS TO BE HELD IN STRICT CONFIDENCE BY YOU. ALL RIGHTS TO ANY INVENTIONS, DESIGNS, TRADE MARKS, TRADE NAMES AND COPYRIGHTS DISCLOSED ARE RESERVED TO TICO TERMINAL SERVICES, INC.			
ANGULAR: ± 0.5°		SIZE	DWG. NO.	REV	
FRACTIONAL ± 1/32"		B	721812-B1	B	
MATERIAL	N/A	SCALE: 1:12	WEIGHT:	SHEET 1 OF 1	
FINISH	N/A				
THICKNESS	N/A				

8 7 6 5 4 3 2 1

