

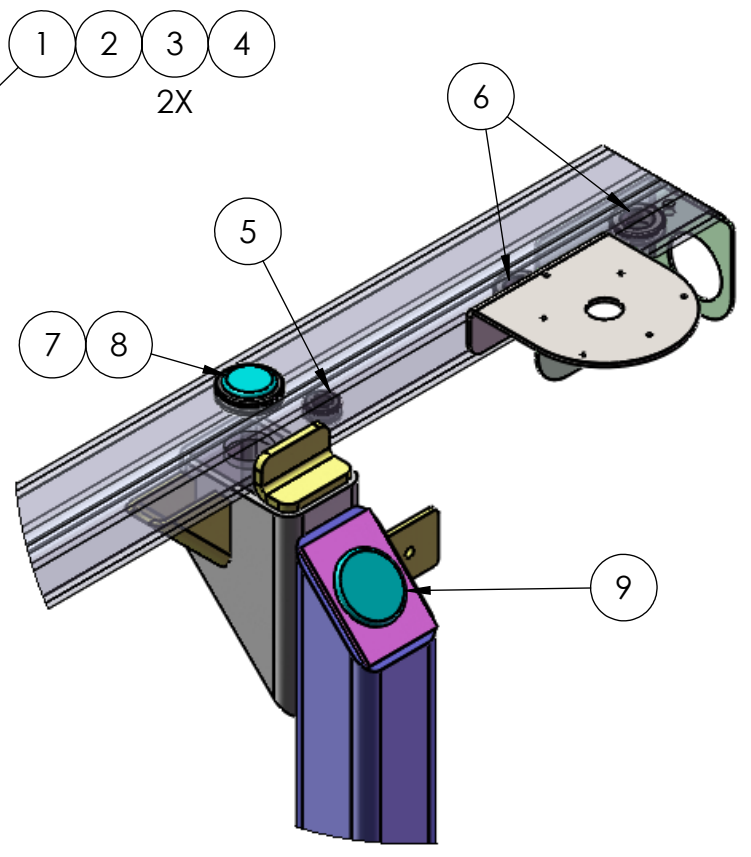

**DETAIL A
SCALE 1 : 7**

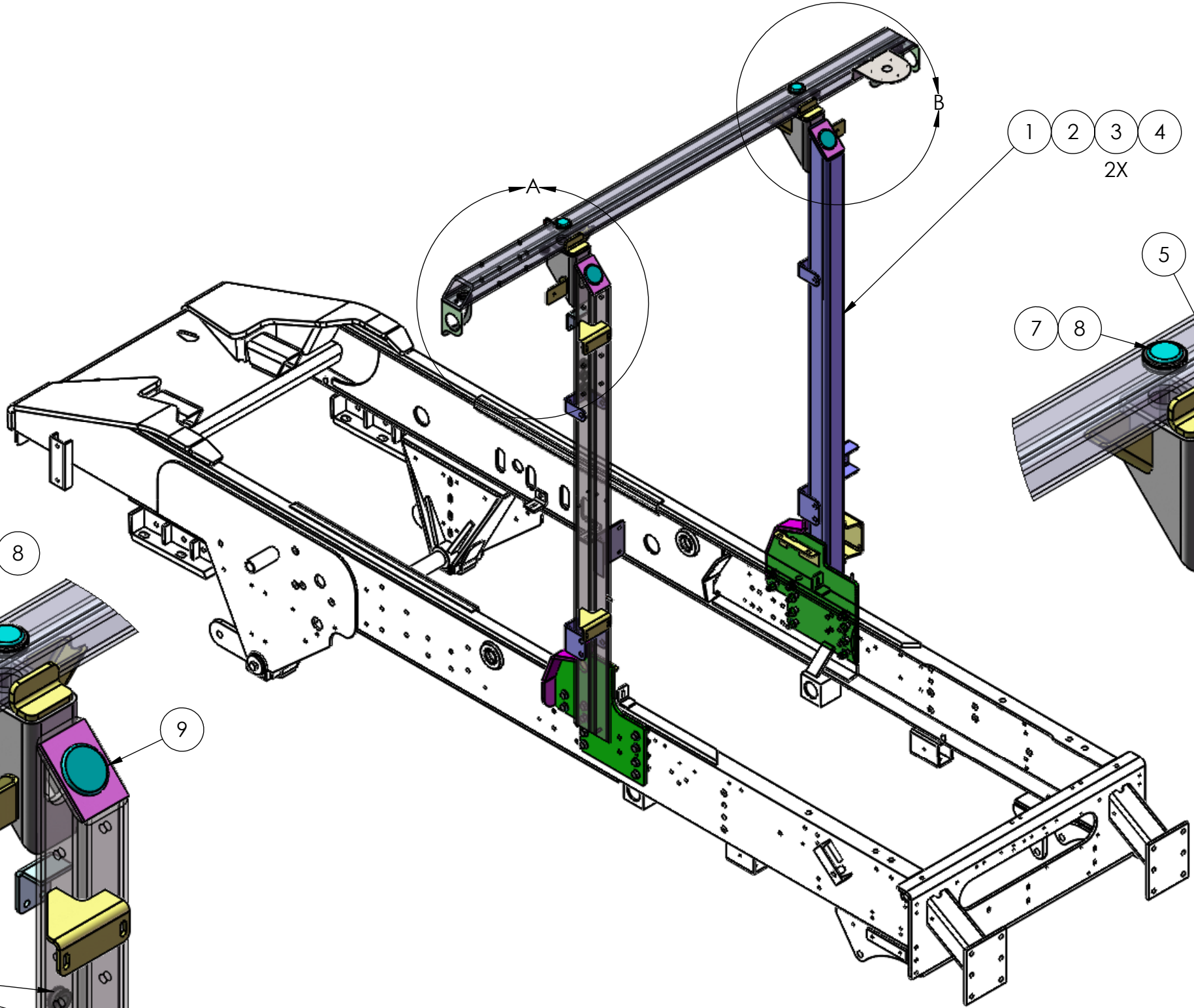

**DETAIL B
SCALE 1 : 7**

DIMENSIONS ARE IN INCHES		NAME	DATE	 TICO/TERMINAL SERVICE 66 CYPRESS RIDGE DR. RIDGELAND, SC 29936 (843) 717-2226
TOLERANCES:		DRAWN	MAL 4/6/2017	
DECIMAL:		CHECKED		
X.X ± 0.06 X.XX ± 0.03 X.XXX ± 0.005		APPROVED		
ANGULAR:		DO NOT SCALE DRAWING		TITLE: ASSEMBLY, CAB BAR, 65" DOOR
FRACTIONAL ± 1/32"				SIZE DWG. NO. REV
INTERPRET GEOMETRIC TOLERANCING PER: ASME 14.5M-1994				B 721761-B1 A
MATERIAL				SCALE: 1:18 WEIGHT: SHEET 1 OF 1
FINISH				
THICKNESS				
THE SUBJECT MATTER SHOWN AND DESCRIBED IN THIS DRAWING AND ANY OTHER INFORMATION ADVANCED IN CONNECTION THEREWITH, IS PROPRIETARY PROPERTY AND IS TO BE HELD IN STRICT CONFIDENCE BY YOU. ALL RIGHTS TO ANY INVENTIONS, DESIGNS, TRADE MARKS, TRADE NAMES AND COPYRIGHTS DISCLOSED ARE RESERVED TO TICO TERMINAL SERVICES, INC.				

