

DIMENSIONS ARE IN INCHES
 TOLERANCES:
 DECIMAL:
 X.X ± 0.06
 X.XX ± 0.03
 X.XXX ± 0.005
 ANGULAR:
 ± 0.5°
 FRACTIONAL ± 1/32"

MATERIAL
 FINISH
 THICKNESS

	NAME	DATE
DRAWN	MPC	01/29/2018
CHECKED		
APPROVED		

DO NOT SCALE DRAWING

THE SUBJECT MATTER SHOWN AND DESCRIBED IN THIS DRAWING AND ANY OTHER INFORMATION ADVANCED IN CONNECTION THEREWITH, IS PROPRIETARY PROPERTY AND IS TO BE HELD IN STRICT CONFIDENCE BY YOU. ALL RIGHTS TO ANY INVENTIONS, DESIGNS, TRADE MARKS, TRADE NAMES AND COPYRIGHTS DISCLOSED ARE RESERVED TO TICO TERMINAL SERVICES, INC.



TICO MANUFACTURING
 66 CYPRESS RIDGE DR.
 RIDGELAND, SC 29936
 (843) 717-2226

TITLE: ASSEMBLY, LIGHTS & MOUNTING

SIZE B	DWG. NO. 721737-A1	REV A
------------------	-----------------------	-----------------

SCALE: 1:17 WEIGHT: SHEET 1 OF 3

8 7 6 5 4 3 2 1

D
C
B
A

1 2 3

5 6 7 8
2X

4

9 10

11 12 13 14
2X

15 16

4

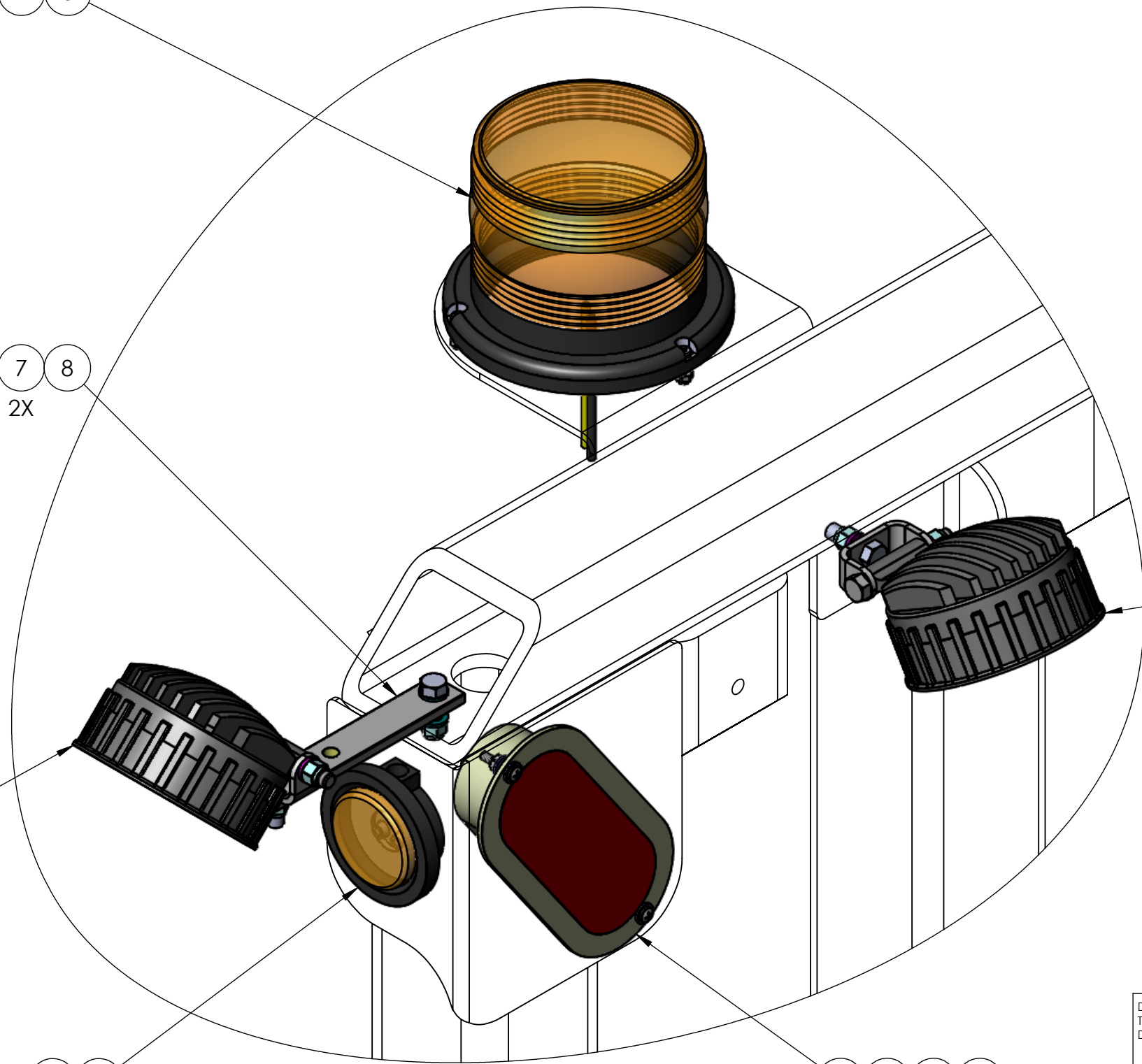
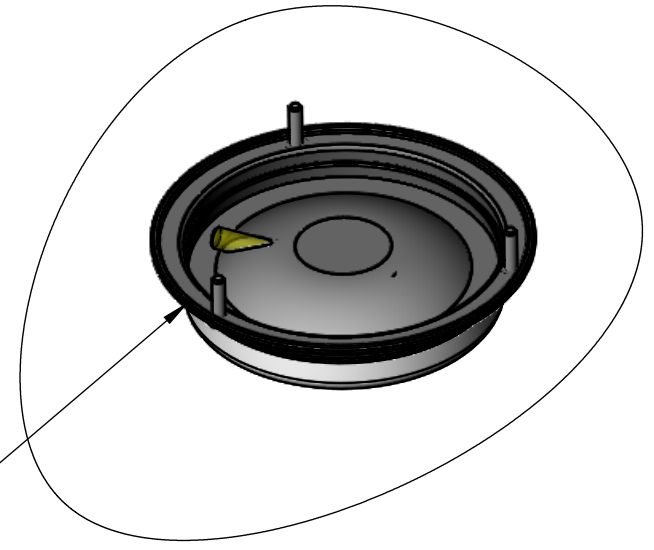

DIMENSIONS ARE IN INCHES		NAME	DATE	 TICO/TERMINAL SERVICE 66 CYPRESS RIDGE DR. RIDGELAND, SC 29936 (843) 717-2226
TOLERANCES:		DRAWN	MPC 01/29/2018	
DECIMAL:		CHECKED		
X.X ± 0.06 X.XX ± 0.03 X.XXX ± 0.005		APPROVED		
ANGULAR:		DO NOT SCALE DRAWING		TITLE: ASSEMBLY, LIGHTS & MOUNTING
FRACTIONAL ± 1/32"				SIZE B
INTERPRET GEOMETRIC TOLERANCING PER: ASME 14.5M-1994		THE SUBJECT MATTER SHOWN AND DESCRIBED IN THIS DRAWING AND ANY OTHER INFORMATION ADVANCED IN CONNECTION THEREWITH, IS PROPRIETARY PROPERTY AND IS TO BE HELD IN STRICT CONFIDENCE BY YOU. ALL RIGHTS TO ANY INVENTIONS, DESIGNS, TRADE MARKS, TRADE NAMES AND COPYRIGHTS DISCLOSED ARE RESERVED TO TICO TERMINAL SERVICES, INC.		DWG. NO. 721737-A1
MATERIAL				REV A
FINISH				SCALE: 1:18
THICKNESS				WEIGHT:
				SHEET 2 OF 3

8 7 6 5 4 3 2 1

8 7 6 5 4 3 2 1

D
C
B
A

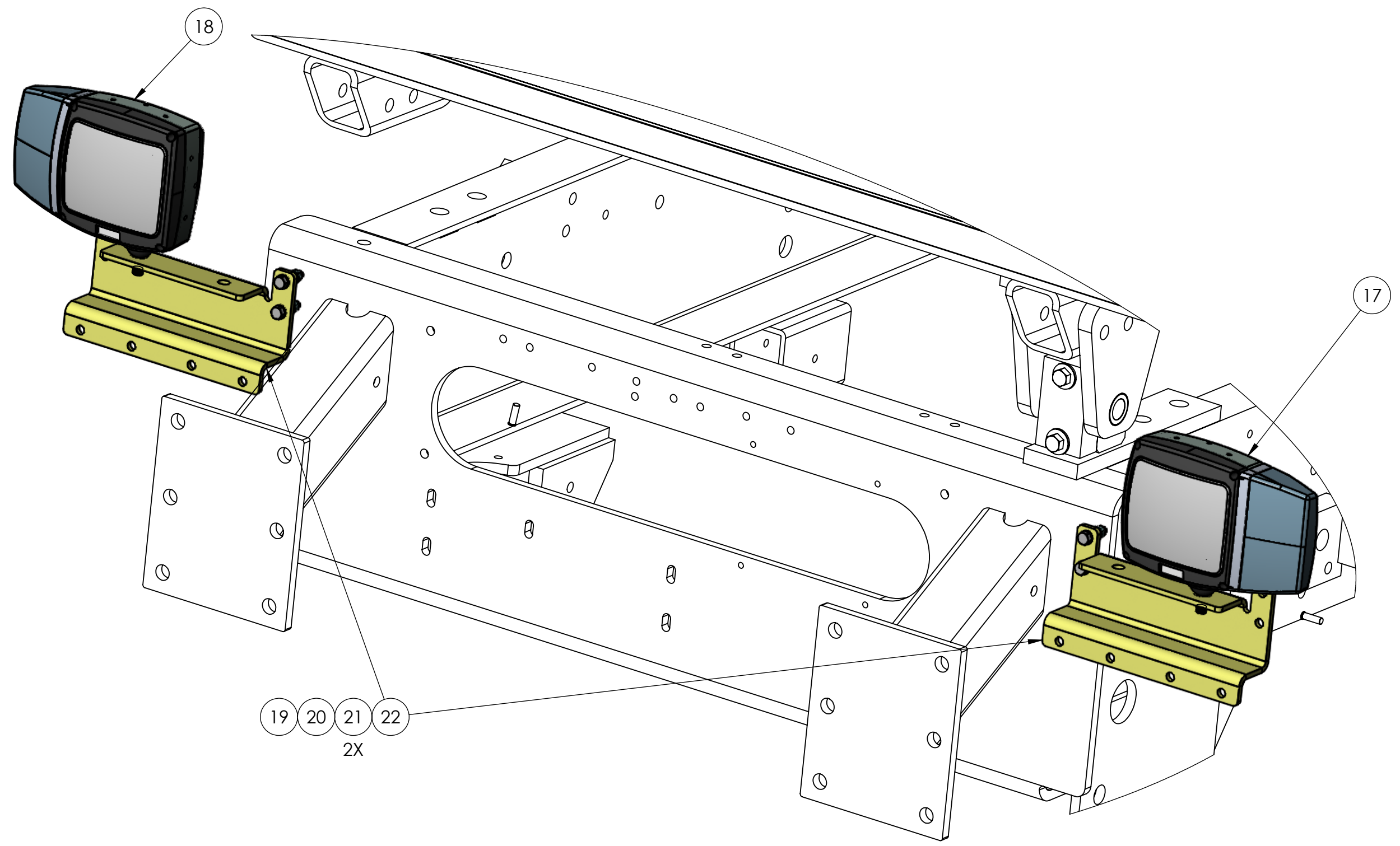

19 20 21 22
2X

DIMENSIONS ARE IN INCHES TOLERANCES: DECIMAL: X.X ± 0.06 X.XX ± 0.03 X.XXX ± 0.005 ANGULAR: ± 0.5° FRACTIONAL ± 1/32"	NAME MPC	DATE 01/29/2018	 TICO/TERMINAL SERVICE 66 CYPRESS RIDGE DR. RIDGELAND, SC 29936 (843) 717-2226
	DRAWN		
	CHECKED		
	APPROVED		
INTERPRET GEOMETRIC TOLERANCING PER: ASME 14.5M-1994	DO NOT SCALE DRAWING		TITLE: ASSEMBLY, LIGHTS & MOUNTING
MATERIAL	THE SUBJECT MATTER SHOWN AND DESCRIBED IN THIS DRAWING AND ANY OTHER INFORMATION ADVANCED IN CONNECTION THEREWITH, IS PROPRIETARY PROPERTY AND IS TO BE HELD IN STRICT CONFIDENCE BY YOU. ALL RIGHTS TO ANY INVENTIONS, DESIGNS, TRADE MARKS, TRADE NAMES AND COPYRIGHTS DISCLOSED ARE RESERVED TO TICO TERMINAL SERVICES, INC.		SIZE B
FINISH	DWG. NO. 721737-A1		REV A
THICKNESS	SCALE: 1:18	WEIGHT:	SHEET 3 OF 3

8 7 6 5 4 3 2 1

