

DIMENSIONS ARE IN INCHES  
 TOLERANCES:  
 DECIMAL:  
 X.X ± 0.06  
 X.XX ± 0.03  
 X.XXX ± 0.005  
 ANGULAR:  
 ± 0.5°  
 FRACTIONAL ± 1/32"

INTERPRET GEOMETRIC TOLERANCING  
 PER: ASME 14.5M-1994

MATERIAL

FINISH

THICKNESS

	NAME	DATE
DRAWN	MPC	01/31/2018
CHECKED		
APPROVED		



TICO/TERMINAL SERVICE  
 66 CYPRESS RIDGE DR.  
 RIDGELAND, SC 29936  
 (843) 717-2226

TITLE: ASSEMBLY, MIRRORS, 102"

DO NOT SCALE DRAWING

THE SUBJECT MATTER SHOWN AND DESCRIBED IN THIS DRAWING AND ANY OTHER INFORMATION ADVANCED IN CONNECTION THEREWITH, IS PROPRIETARY PROPERTY AND IS TO BE HELD IN STRICT CONFIDENCE BY YOU. ALL RIGHTS TO ANY INVENTIONS, DESIGNS, TRADE MARKS, TRADE NAMES AND COPYRIGHTS DISCLOSED ARE RESERVED TO TICO TERMINAL SERVICES, INC.

SIZE <b>B</b>	DWG. NO. 721735-A1	REV <b>A</b>
SCALE: 1:12	WEIGHT:	SHEET 1 OF 3

8 7 6 5 4 3 2 1

D  
C  
B  
A

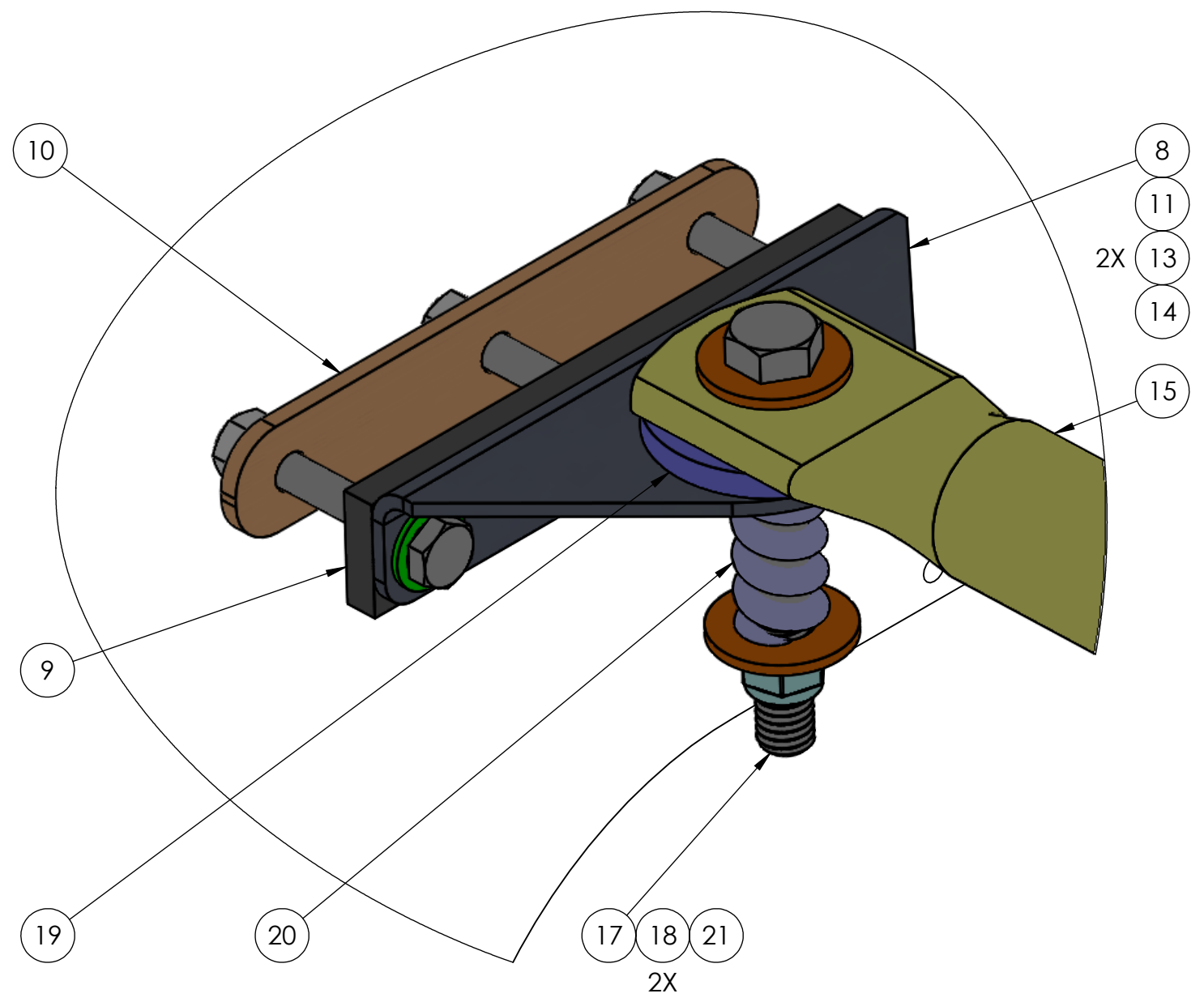
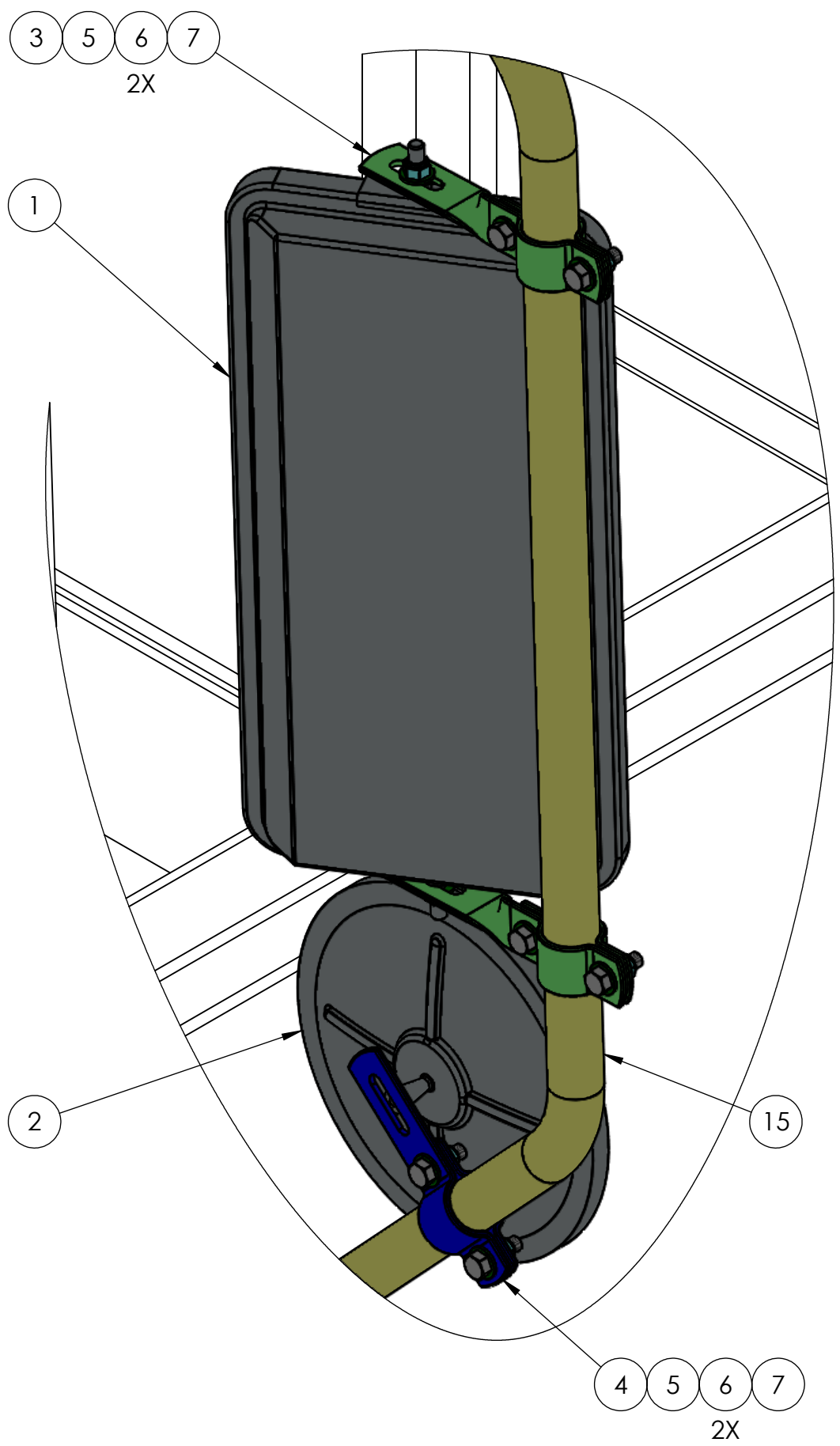

D  
C  
B  
A

DIMENSIONS ARE IN INCHES TOLERANCES: DECIMAL: X.X ± 0.06 X.XX ± 0.03 X.XXX ± 0.005 ANGULAR: ± 0.5° FRACTIONAL ± 1/32"	NAME	DATE	 TICO/TERMINAL SERVICE 66 CYPRESS RIDGE DR. RIDGELAND, SC 29936 (843) 717-2226	
	DRAWN	MPC		01/31/2018
	CHECKED			
	APPROVED			
INTERPRET GEOMETRIC TOLERANCING PER: ASME 14.5M-1994	DO NOT SCALE DRAWING		TITLE: ASSEMBLY, MIRRORS, 102"	
MATERIAL FINISH THICKNESS	THE SUBJECT MATTER SHOWN AND DESCRIBED IN THIS DRAWING AND ANY OTHER INFORMATION ADVANCED IN CONNECTION THEREWITH, IS PROPRIETARY PROPERTY AND IS TO BE HELD IN STRICT CONFIDENCE BY YOU. ALL RIGHTS TO ANY INVENTIONS, DESIGNS, TRADE MARKS, TRADE NAMES AND COPYRIGHTS DISCLOSED ARE RESERVED TO TICO TERMINAL SERVICES, INC.		SIZE <b>B</b>	
	DWG. NO.	REV		
	721735-A1	A		
	SCALE: 1:12	WEIGHT:	SHEET 2 OF 3	

8 7 6 5 4 3 2 1

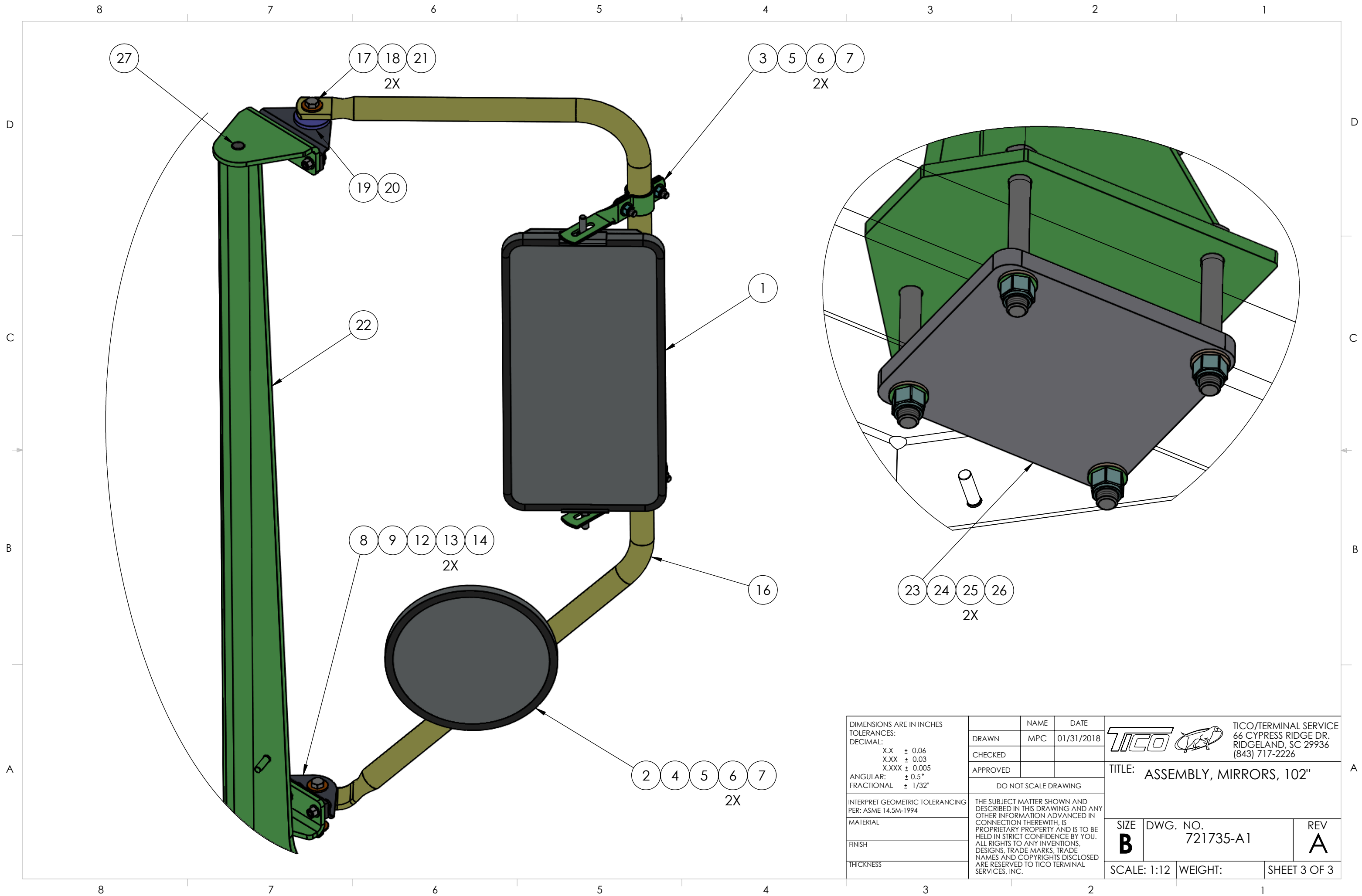

DIMENSIONS ARE IN INCHES TOLERANCES: DECIMAL: X.X ± 0.06 X.XX ± 0.03 X.XXX ± 0.005 ANGULAR: ± 0.5° FRACTIONAL ± 1/32"	NAME	DATE	 TICO/TERMINAL SERVICE 66 CYPRESS RIDGE DR. RIDGELAND, SC 29936 (843) 717-2226	
	DRAWN	MPC		01/31/2018
	CHECKED			
	APPROVED			
DO NOT SCALE DRAWING			TITLE: ASSEMBLY, MIRRORS, 102"	
INTERPRET GEOMETRIC TOLERANCING PER: ASME 14.5M-1994	THE SUBJECT MATTER SHOWN AND DESCRIBED IN THIS DRAWING AND ANY OTHER INFORMATION ADVANCED IN CONNECTION THEREWITH, IS PROPRIETARY PROPERTY AND IS TO BE HELD IN STRICT CONFIDENCE BY YOU. ALL RIGHTS TO ANY INVENTIONS, DESIGNS, TRADE MARKS, TRADE NAMES AND COPYRIGHTS DISCLOSED ARE RESERVED TO TICO TERMINAL SERVICES, INC.		SIZE	
MATERIAL			DWG. NO.	
FINISH			721735-A1	
THICKNESS			REV	
			A	
	SCALE: 1:12	WEIGHT:	SHEET 3 OF 3	

