

**FRONT MODULATOR  
PLATE ASSEMBLY**

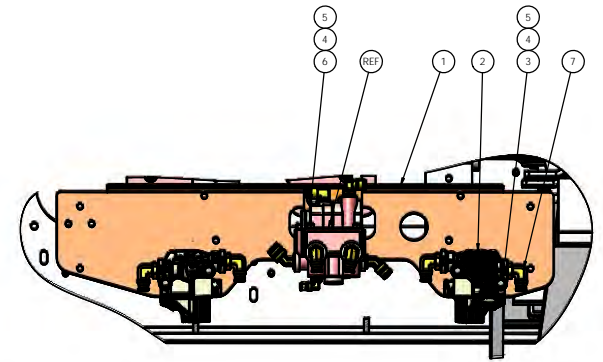

**REAR MODULATOR  
PLATE ASSEMBLY**

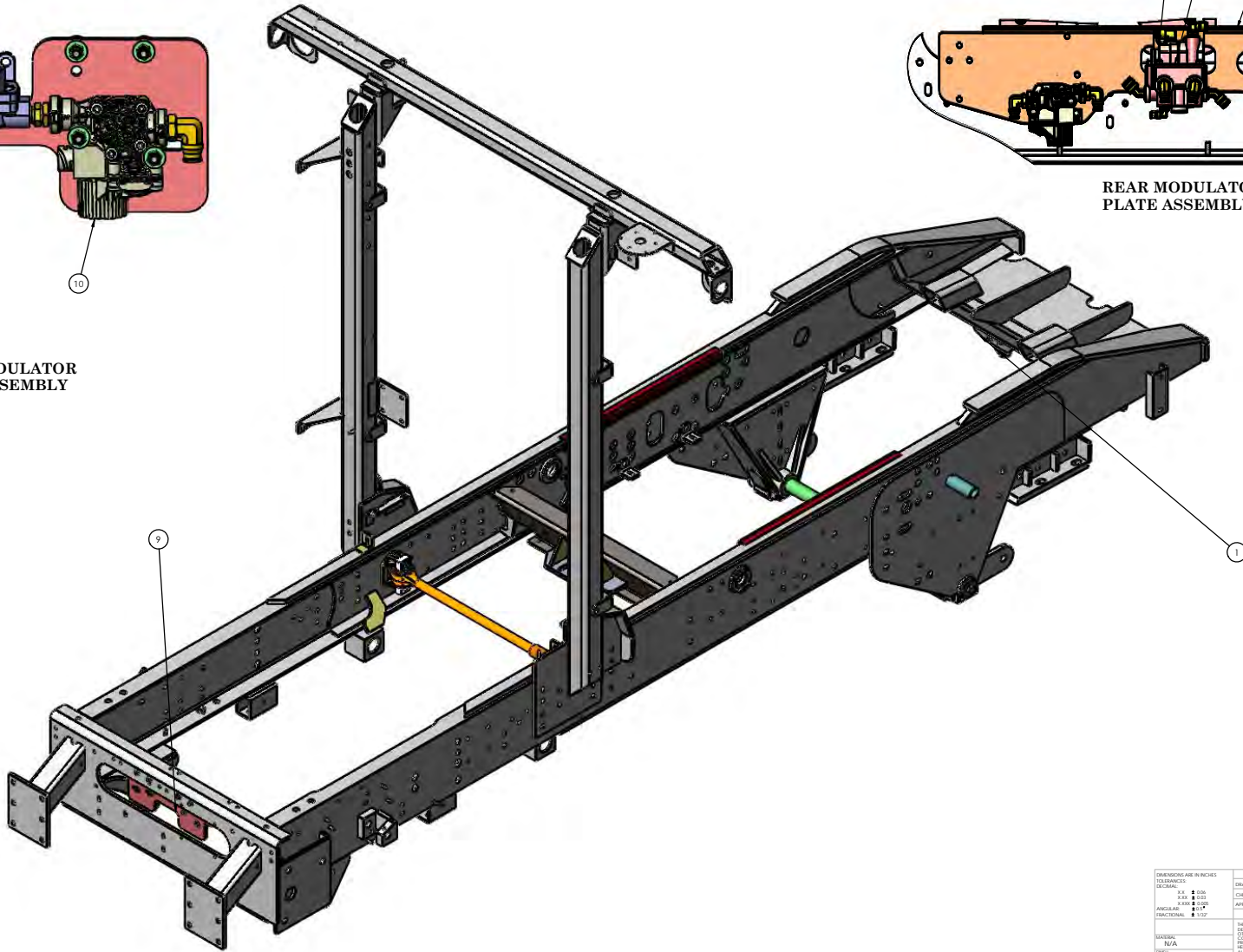

DIMENSIONS ARE IN INCHES		NAME	DATE
TOLERANCES:		DRWGR	MAL 11/28/2017
DECIMAL:		CHECKED	
.005 & .006		APPROVED	
.005 & .010			
.010 & .015			
ANGULAR:		DOTED SCALE DRAWING	
FRACTIONAL: <math>\frac{1}{16}</math>		THE SUBJECT MATTER SHOWN AND	
		DESCRIBED IN THE DRAWING AND ANY	
		OTHER INFORMATION IS UNLESS NOTED BY	
		SPECIFICALLY REFERENCED TO IN THE	
		TITLE BLOCK. CONSTRUCTION OF THIS	
		DRAWING SHALL BE IN ACCORDANCE WITH	
		ALL RIGHTS TO ANY PATENT, TRADE	
		MARK, AND COPYRIGHTS OWNED BY	
		ABS BELONG TO THE TRADEMARK	
		SERVICE, INC.	
SCALE: 1:32 [WEIGHT: 3030.02] SHEET 1 OF 1	SIZE	DWG. NO.	REV
	D	721629-C1	

D 721629-C1

REV.	DESCRIPTION	ECN	DATE	APPROVED
A	PRODUCTION RELEASE	10225	1/21/10	HK
B	REVISED AIR TANKS ROUTING	10290	5/10/11	HK

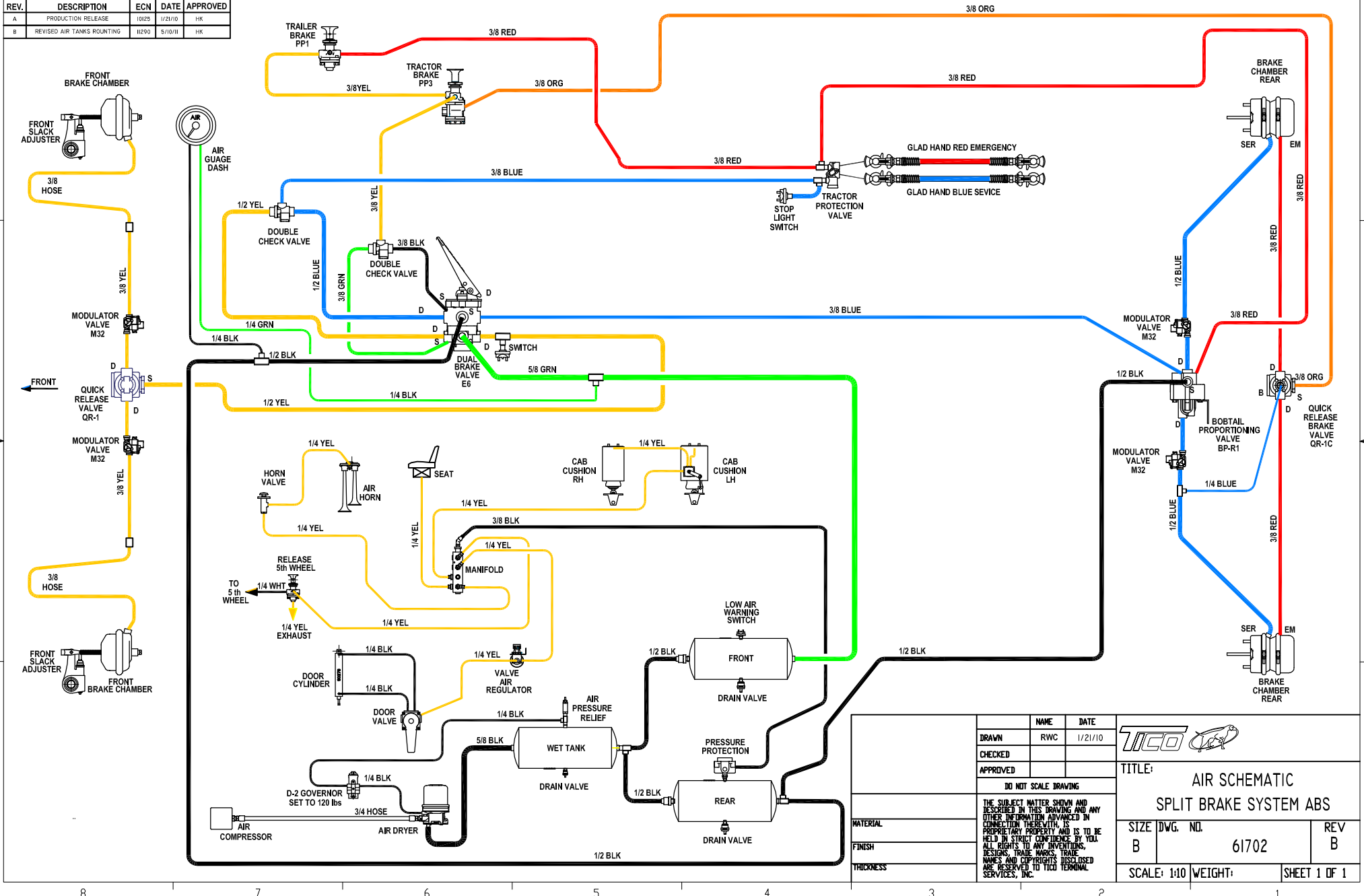

MATERIAL	NAME	DATE	
	DRAWN	RWC 1/21/10	
	CHECKED		
	APPROVED		
DO NOT SCALE DRAWING			TITLE:
<small>THE SUBJECT MATTER SHOWN AND DESCRIBED IN THIS DRAWING AND ANY OTHER INFORMATION ADVANCED IN CONNECTION THEREWITH, IS PROPRIETARY PROPERTY AND IS TO BE HELD IN STRICT CONFIDENCE BY YOU. ALL RIGHTS TO ANY INVENTIONS, DESIGNS, TRADE MARKS, TRADE NAMES AND COPYRIGHTS DISCLOSED ARE RESERVED TO TICO TERMINAL SERVICES, INC.</small>			AIR SCHEMATIC SPLIT BRAKE SYSTEM ABS
FINISH	SIZE DWG. NO.	B	REV
THICKNESS	B	61702	B
	SCALE: 1:10	WEIGHT:	SHEET 1 OF 1

