

**CHASSIS PDC & COVER  
PAGE 3**

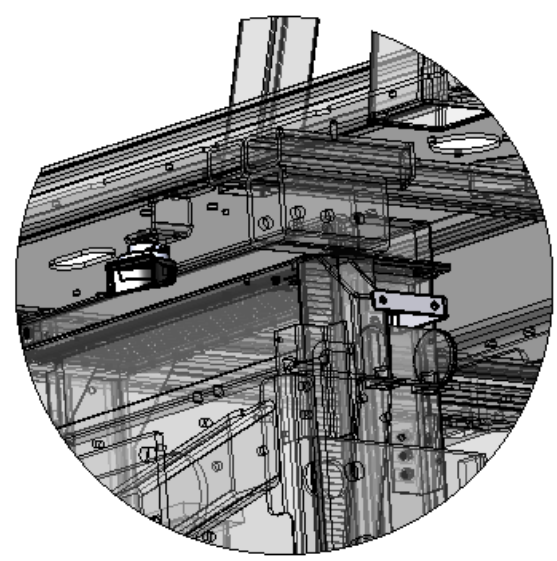

**HORN & WIRING BRACKET  
PAGE 3**

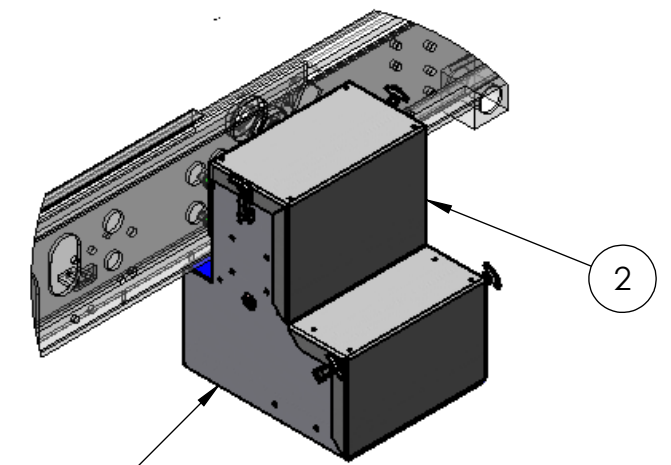
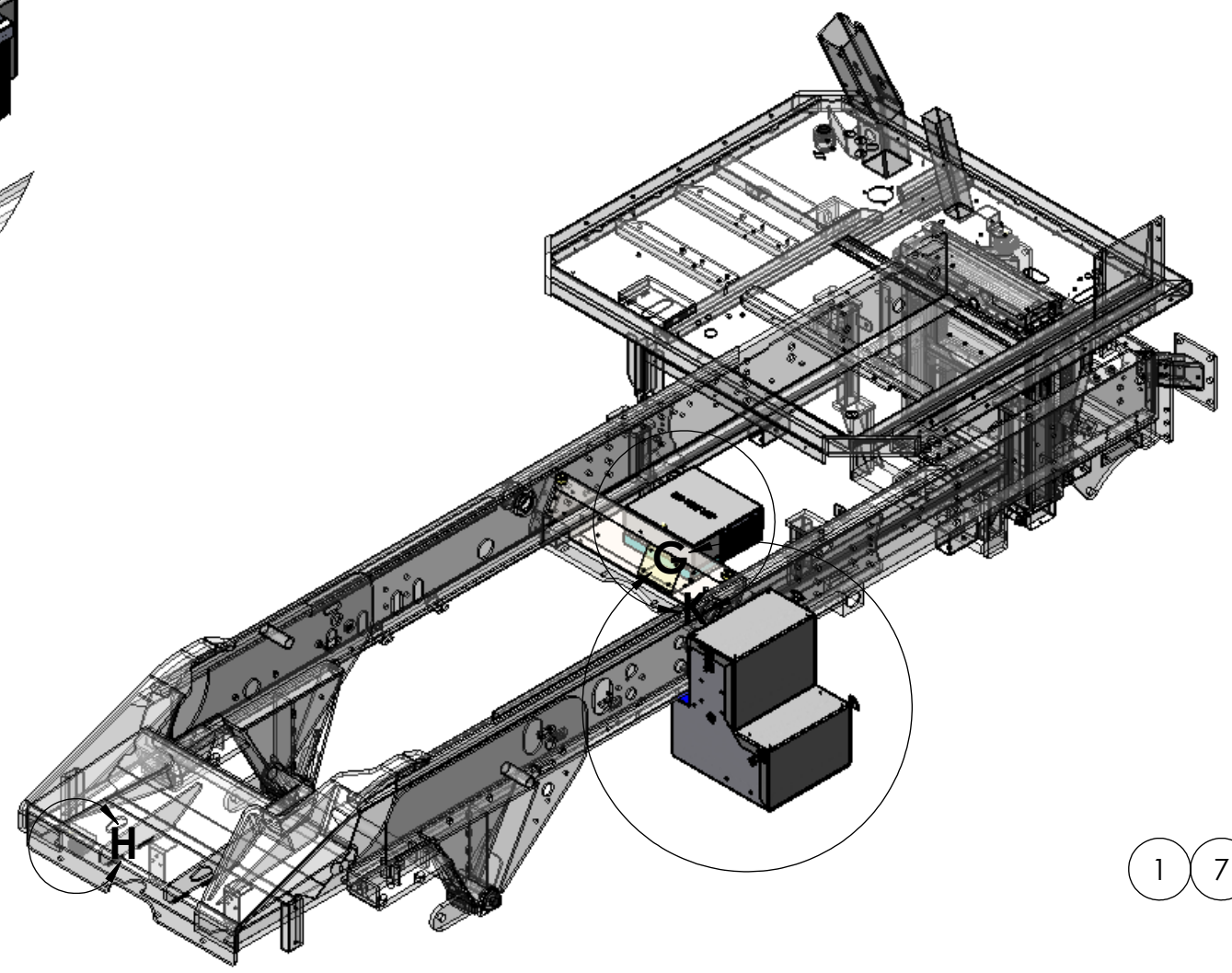

**BATTERY BOX  
PAGE 2**

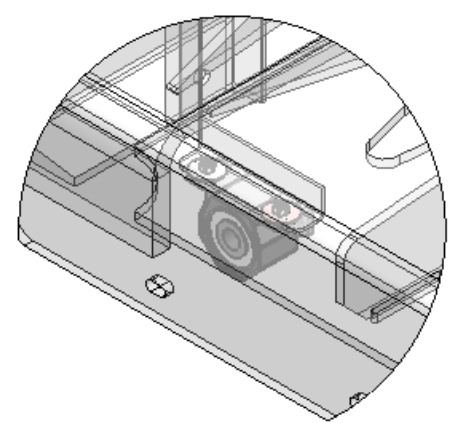

**BACKUP ALARM  
PAGE 2**

DIMENSIONS ARE IN INCHES TOLERANCES: DECIMAL: X.X ± 0.06 X.XX ± 0.03 X.XXX ± 0.005 ANGULAR: ± 0.5° FRACTIONAL ± 1/32"	DRAWN MPC	NAME MPC	DATE 3/7/2017	 TICO/TERMINAL SERVICE 66 CYPRESS RIDGE DR. RIDGELAND, SC 29936 (843) 717-2226
	CHECKED			
	APPROVED			
	DO NOT SCALE DRAWING			
INTERPRET GEOMETRIC TOLERANCING PER: ASME 14.5M-1994	THE SUBJECT MATTER SHOWN AND DESCRIBED IN THIS DRAWING AND ANY OTHER INFORMATION ADVANCED IN CONNECTION THEREWITH, IS PROPRIETARY PROPERTY AND IS TO BE HELD IN STRICT CONFIDENCE BY YOU. ALL RIGHTS TO ANY INVENTIONS, DESIGNS, TRADE MARKS, TRADE NAMES AND COPYRIGHTS DISCLOSED ARE RESERVED TO TICO TERMINAL SERVICES, INC.			TITLE: ASSEMBLY, BATTERY & WIRING
MATERIAL	SIZE <b>B</b>	DWG. NO. 721600-A 1	REV	
FINISH	SCALE: 1:48	WEIGHT:	SHEET 1 OF 3	
THICKNESS				

8 7 6 5 4 3 2 1

D  
C  
B  
A

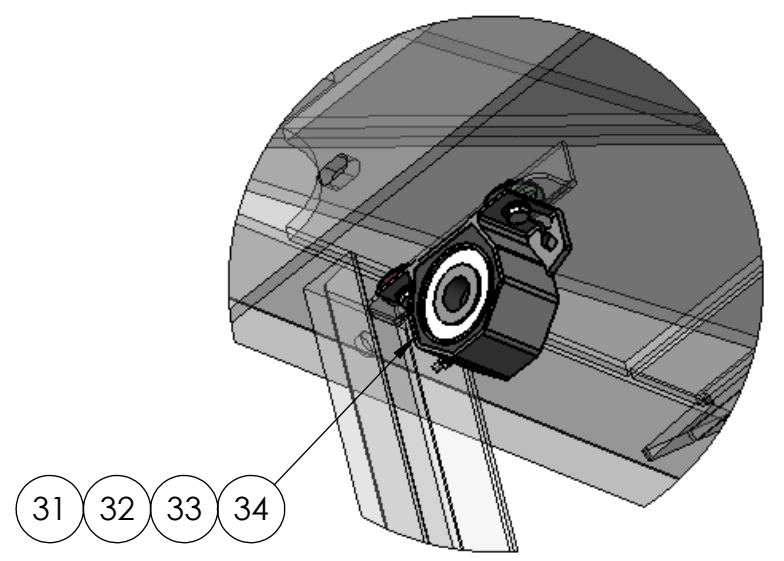
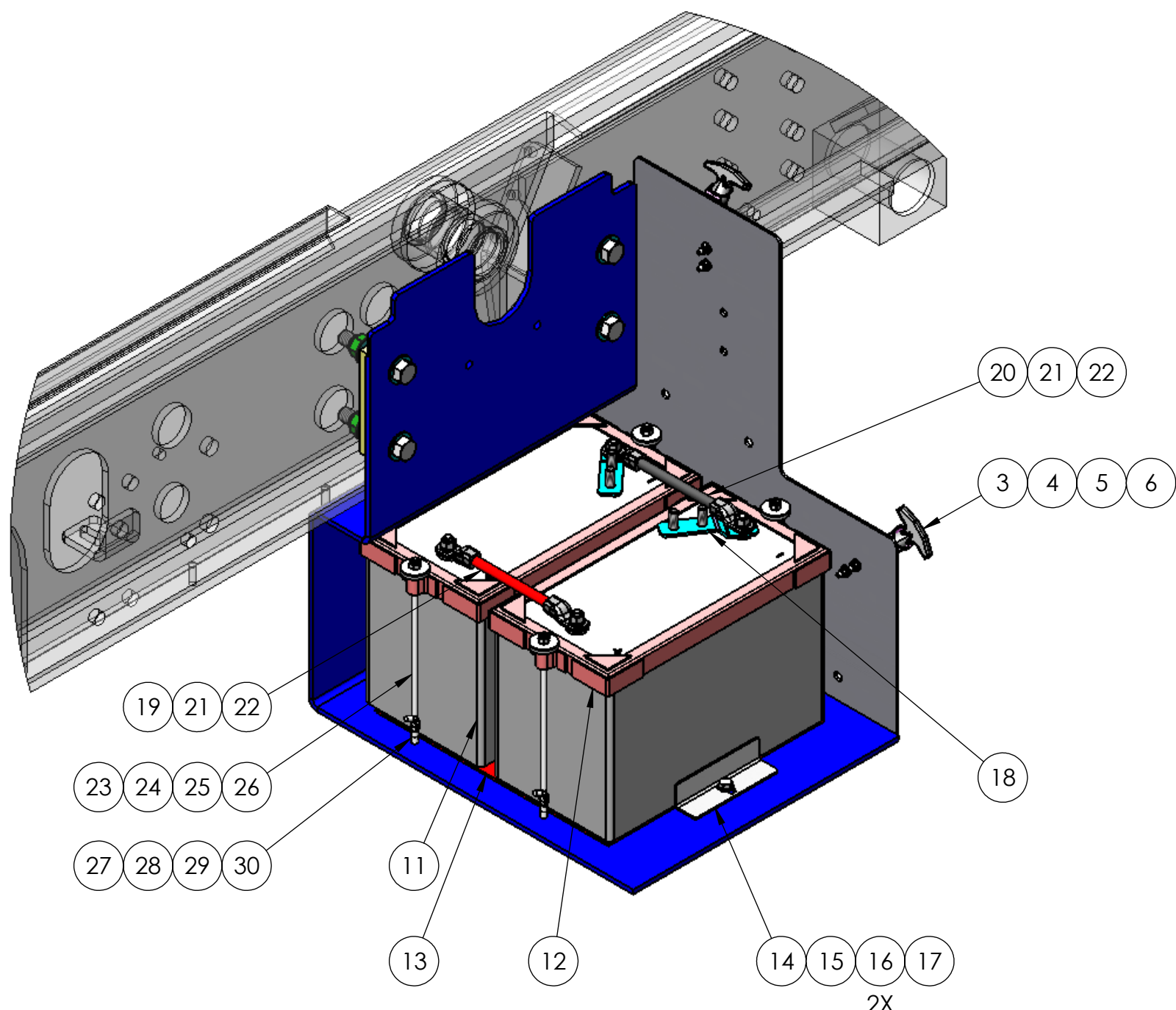

D  
C  
B  
A

8 7 6 5 4 3 2 1

DIMENSIONS ARE IN INCHES TOLERANCES: DECIMAL: X.X ± 0.06 X.XX ± 0.03 X.XXX ± 0.005 ANGULAR: ± 0.5° FRACTIONAL ± 1/32"		NAME MPC	DATE 3/7/2017	 TICO/TERMINAL SERVICE 66 CYPRESS RIDGE DR. RIDGELAND, SC 29936 (843) 717-2226	
INTERPRET GEOMETRIC TOLERANCING PER: ASME 14.5M-1994		CHECKED	APPROVED		TITLE: ASSEMBLY, BATTERY & WIRING
MATERIAL		DO NOT SCALE DRAWING		SIZE <b>B</b>	
FINISH		THE SUBJECT MATTER SHOWN AND DESCRIBED IN THIS DRAWING AND ANY OTHER INFORMATION ADVANCED IN CONNECTION THEREWITH, IS PROPRIETARY PROPERTY AND IS TO BE HELD IN STRICT CONFIDENCE BY YOU. ALL RIGHTS TO ANY INVENTIONS, DESIGNS, TRADE MARKS, TRADE NAMES AND COPYRIGHTS DISCLOSED ARE RESERVED TO TICO TERMINAL SERVICES, INC.			DWG. NO. 721600-A1
THICKNESS		SCALE: 1:48		WEIGHT:	REV SHEET 2 OF 3

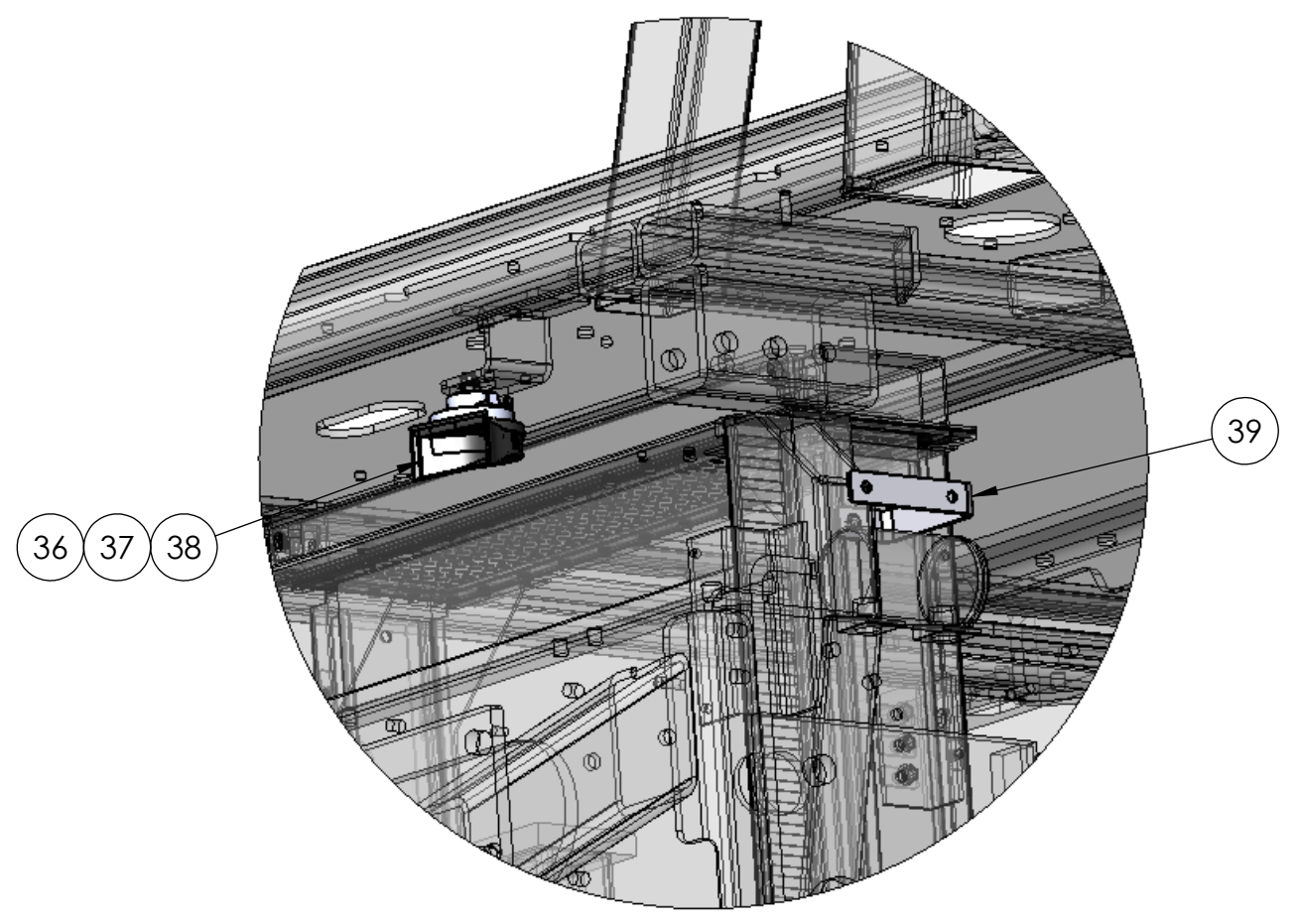
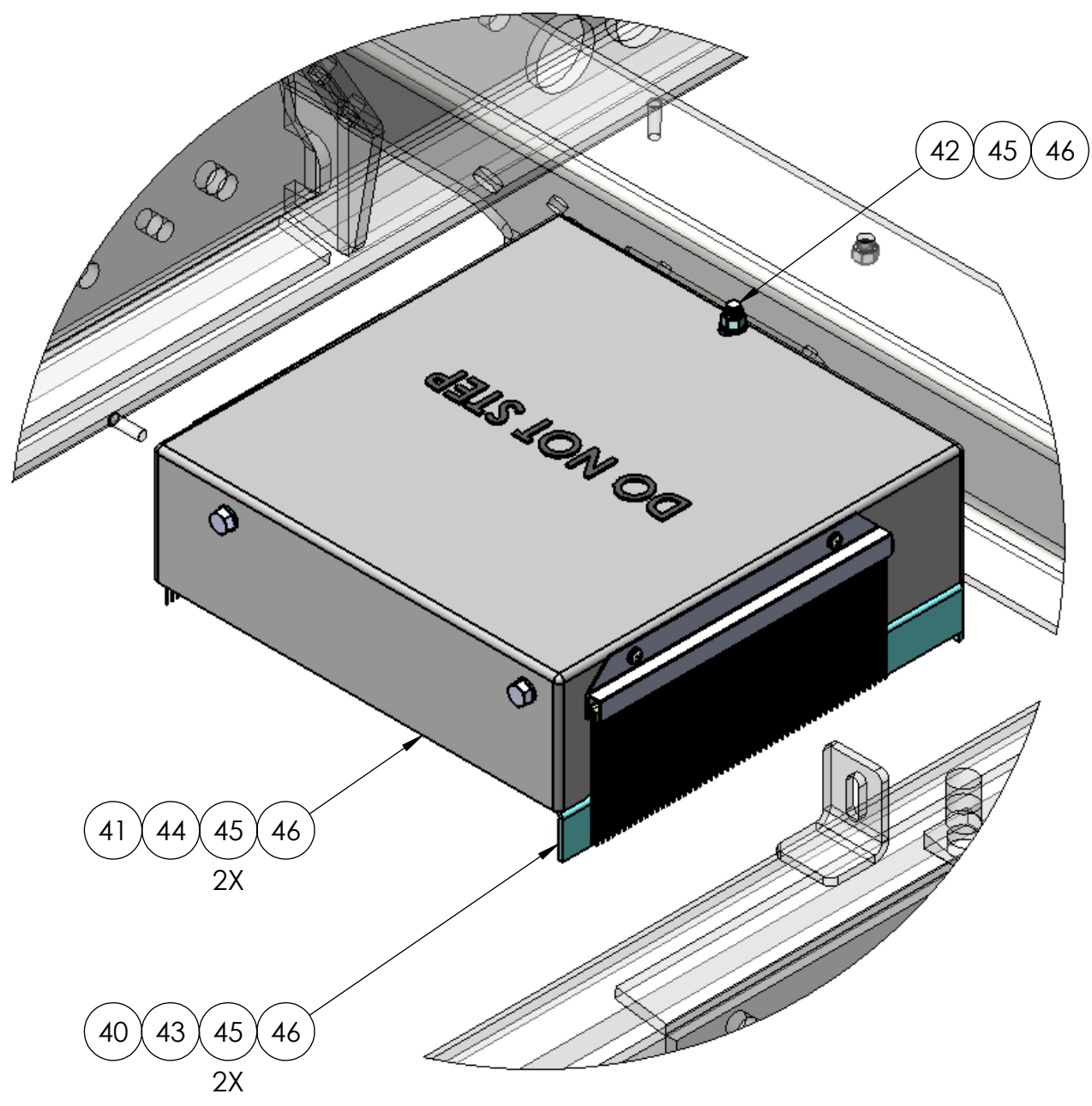

DIMENSIONS ARE IN INCHES		NAME	DATE	 TICO/TERMINAL SERVICE 66 CYPRESS RIDGE DR. RIDGELAND, SC 29936 (843) 717-2226	
TOLERANCES:		DRAWN	MPC		3/7/2017
DECIMAL:		CHECKED			
X.X ± 0.06 X.XX ± 0.03 X.XXX ± 0.005		APPROVED			
ANGULAR: ± 0.5°		DO NOT SCALE DRAWING			
FRACTIONAL ± 1/32"		TITLE: ASSEMBLY, BATTERY & WIRING			
INTERPRET GEOMETRIC TOLERANCING PER: ASME 14.5M-1994		SIZE B DWG. NO. 721600-A1 REV			
MATERIAL		SCALE: 1:48 WEIGHT: SHEET 3 OF 3			
FINISH		THE SUBJECT MATTER SHOWN AND DESCRIBED IN THIS DRAWING AND ANY OTHER INFORMATION ADVANCED IN CONNECTION THEREWITH, IS PROPRIETARY PROPERTY AND IS TO BE HELD IN STRICT CONFIDENCE BY YOU. ALL RIGHTS TO ANY INVENTIONS, DESIGNS, TRADE MARKS, TRADE NAMES AND COPYRIGHTS DISCLOSED ARE RESERVED TO TICO TERMINAL SERVICES, INC.			
THICKNESS					





