

REFERENCES ARE IN INCHES	ISSUE	DATE	 WECO MANUFACTURING 44 CYPRESS RIDGE DR. ROCKLAND, NC 27854 (843) 317-2226
DIMENSIONS: DECIMALS .0005 FRACTIONS 1/32 ANGULAR ±0.1° FUNCTIONAL ±0.12°	DESIGNER CHECKED APPROVED	4/8/2017	
UNLESS OTHERWISE SPECIFIED, ALL DIMENSIONS ARE TO BE TAKEN FROM THE DIMENSIONED SURFACE UNLESS OTHERWISE SPECIFIED. ALL DIMENSIONS ARE TO BE TAKEN FROM THE DIMENSIONED SURFACE UNLESS OTHERWISE SPECIFIED. ALL DIMENSIONS ARE TO BE TAKEN FROM THE DIMENSIONED SURFACE UNLESS OTHERWISE SPECIFIED.			TITLE: ENGINE & TRANSMISSION
DRAWN: DESIGNED: CHECKED: APPROVED:	SIZE: D SCALE: 1:8	DWG. NO.: 721592-A1 WEIGHT: 5278	REV: SHEET 1 OF 2

721592-A1

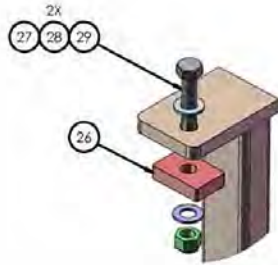

DEIAIL D
SCALE 2 : 3



DEIAILG
SCALE 1 : 3

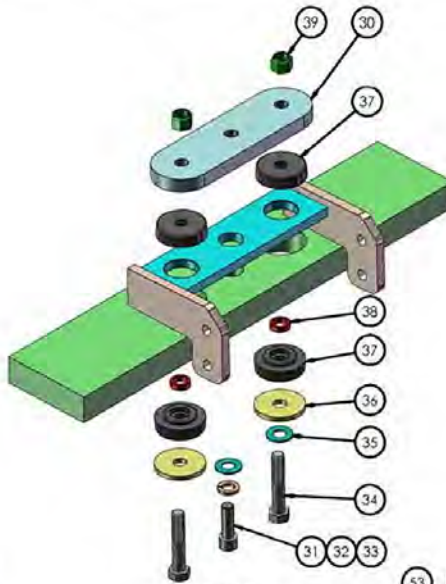

DEIAIL H
SCALE 1 : 3

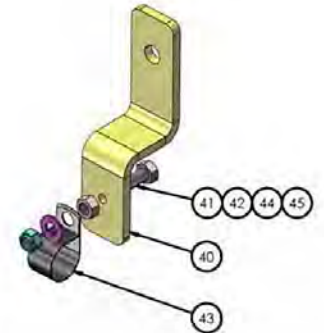

DEIAIL I
SCALE 2 : 3

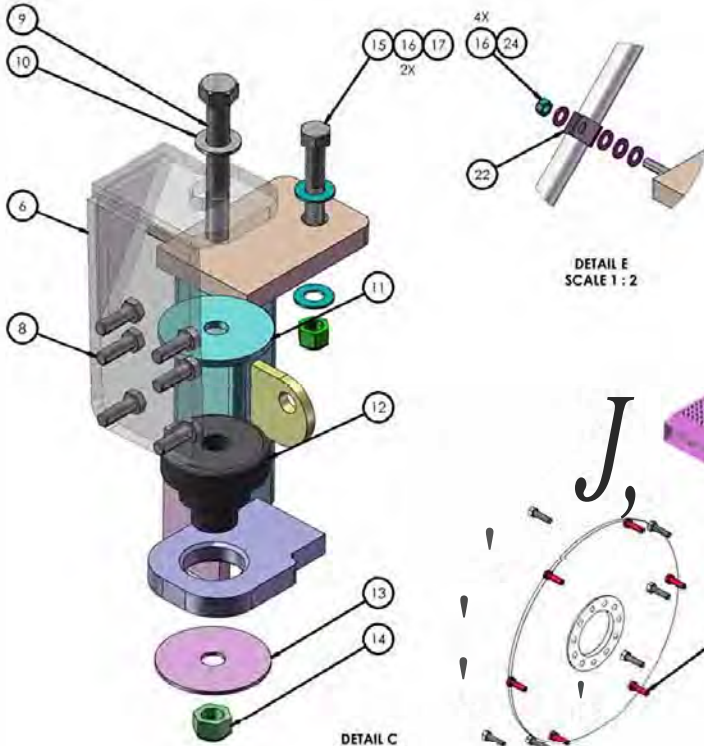

DEIAIL C
SCALE 1 : 2

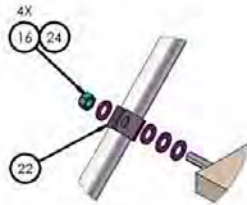

DEIAIL E
SCALE 1 : 2



DEIAIL F
SCALE 1 : 3

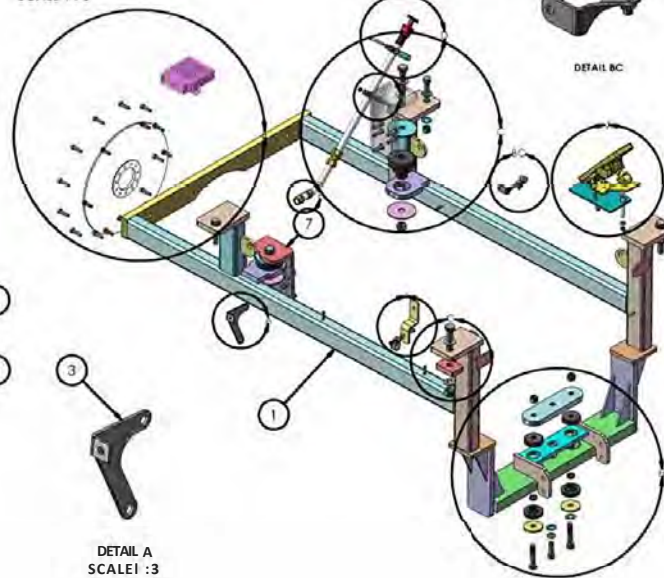

DEIAIL A
SCALE 1 : 3



DEIAIL BC

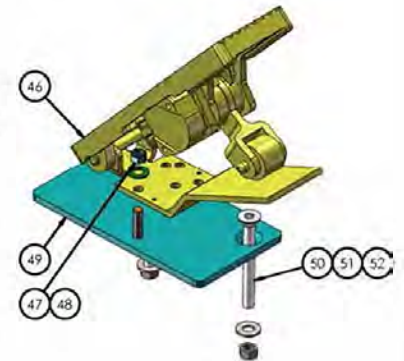

DEIAIL J
SCALE 1 : 2

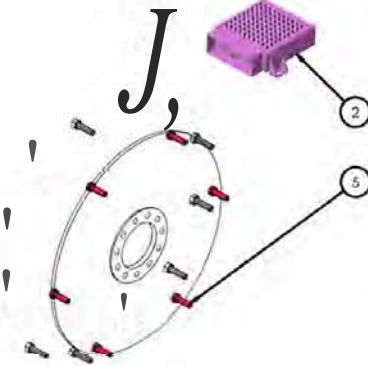

DEIAIL a
SCALE 1 : 4

NOTE: ENGINE A BRAISMESIN NOT SHDWH FOR CLARTY

TICO PRO-SPOTTER				
ENGINE & TRANS 2016 QSB-III, 173 HP@2200, SP CONTROL/RSD3000, 1ST-5TH- GEN V				721592
ITEM	PART #	QTY/M	DESCRIPTION	
26	42070	2	SPACER- ENG CRADLE	
27	82519	2	BOLT-3/4-16NC X 4 1/4LG	
28	85095	4	WASHER-3/4	
29	85029	2	NUT-3/4-10NC NYLOCK	
30	60809	1	MOUNTING PL-FRT ENG	
31	80341	1	BOLT-M16 X 2 X 45mm, 12 PT HD, 10.9	
32				
33	85094	2	WASHER-5/8	
34	82474	2	BOLT-5/8-11UNC x 3 1/4 LG	
35	60113	2	WASHER-5/8	
36	60113	2	WASHER-5/8	
37	60814	4	ISOLATOR FRT ENG MOUNT	
38	10971	2	SPACER-FRT ENG MOUNT	
39	85028	2	NUT-5/8-11UNC CRLK	
40	60956	3	BRACKET-TRANS HOSE	
41	82370	1	BOLT, HEX HD 1/4-20 X 1" LG	
42	85023	1	NUT, HEX NYLOCK 1/4 -20	
43	40593	1	CLAMP, P 1" ID	
44	82508	2	BOLT-3/4-16NC X 4 LG	
45	85029	4	NUT-3/4-10NC NYLOCK	
46	60747	1	PEDAL ACCELERATOR - ELECTRONIC QSB	
47	85113	4	WASHER, FLAT 3/8	
48	85036	2	LOCKNUT, 3/8-16	
49	90632	1	MOUNTING PLATE ELECTRIC THROTTLE	
50	83318	2	SC HC SCREW 3/8-16 x 3 1/2" Lg	
51	85113	4	WASHER, FLAT 3/8	
52	85036	2	LOCKNUT, 3/8-16	
NS	410358	84"	HEATER HOSE, 5/8 x 84 Lg	
NS	60031	1	VALVE NEEDLE, BRASS, # 10 HOSE X 3/8 NPT	
NS	42095	1	FITTING, REDUCER, BRASS, 1/2 MNPT X 3/8 NPT	
NS	410358	96"	HEATER HOSE, 5/8 x 96 Lg	
NS	60031	1	VALVE NEEDLE, BRASS, # 10 HOSE X 3/8 NPT	
NS	42053	1	FITTING, REDUCER, BRASS, 3/4 MNPT X 3/8 NPT	
NS	40844	1	FITTING, ELBOW STREET - 90°, BRASS, 3/8 MNPT X 3/8 NPT	
NS	42055	1	FITTING, HOSE BARB - 90°, 1" HOSE X 3/4NPT	
NS	42150	2	CLAMP, WORMGEAR HOSE #08 LINER 7/16-1	
REV	DATE	BY		SHEET
A	10/10/19	REB		2 OF 3

REV.	DESCRIPTION	ECN	DATE	APPROVED
A	RELEASED	14348	7/18/2014	
B	ADDED NOTES/PART NUMBERS FOR CLARIFICATION	15252	5/11/2015	

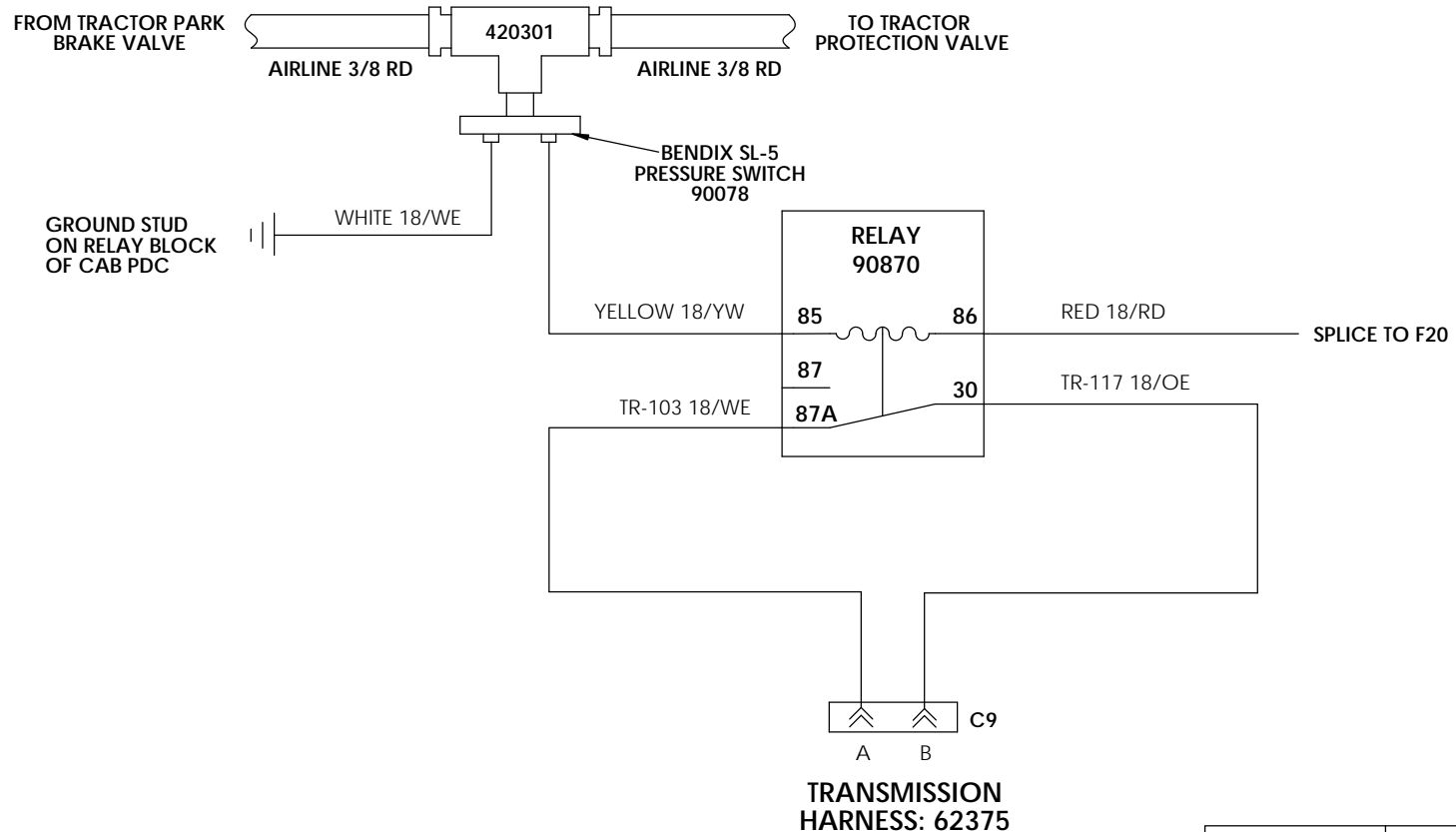

- NOTE:**
1. ALL COMPONENTS ARE TO BE INSTALLED AND SECURED TO PLYWOOD LAMINATE INSIDE DASH.
 2. TRANSMISSION HARNESS 62375 MUST BE USED.
 3. AIRLINES ROUTED OUTSIDE OF DASH MUST HAVE CONVOLUTE TUBING, STOP CONVOLUTE TUBING 1" FROM END OF AIR LINE.

DIMENSIONS ARE IN INCHES TOLERANCES: DECIMAL: XX ± 0.06 X.XX ± 0.03 X.XXX ± 0.005 ANGULAR: ± 0.5° FRACTIONAL: ± 1/32"	DRAWN JK 7/18/2014	TICO/TERMINAL SERVICE 66 CYPRESS RIDGE DR. RIDGELAND, SC 29936 (843) 717-2226	
	CHECKED		TITLE: WIRE SCHEMATIC - AUTO NEUTRAL W/ PARKING BRAKE
	APPROVED		DO NOT SCALE DRAWING
	INTERPRET GEOMETRIC TOLERANCING PER: ASME 14.5M-1994		
MATERIAL	THE SUBJECT MATTER SHOWN AND DESCRIBED IN THIS DRAWING AND ANY OTHER INFORMATION ADVANCED IN CONNECTION THEREWITH, IS PROPRIETARY PROPERTY AND IS TO BE HELD IN STRICT CONFIDENCE BY YOU. ALL RIGHTS TO ANY INVENTIONS, DESIGNS, TRADE MARKS, TRADE NAMES AND COPYRIGHTS DISCLOSED ARE RESERVED TO TICO TERMINAL SERVICES, INC.		
FINISH	SIZE B	DWG. NO. 62377-1	
THICKNESS	SCALE: 1:8	WEIGHT:	
		SHEET 1 OF 1	