

8 7 6 5 4 3 2 1

D
C
B
A

D
C
B
A

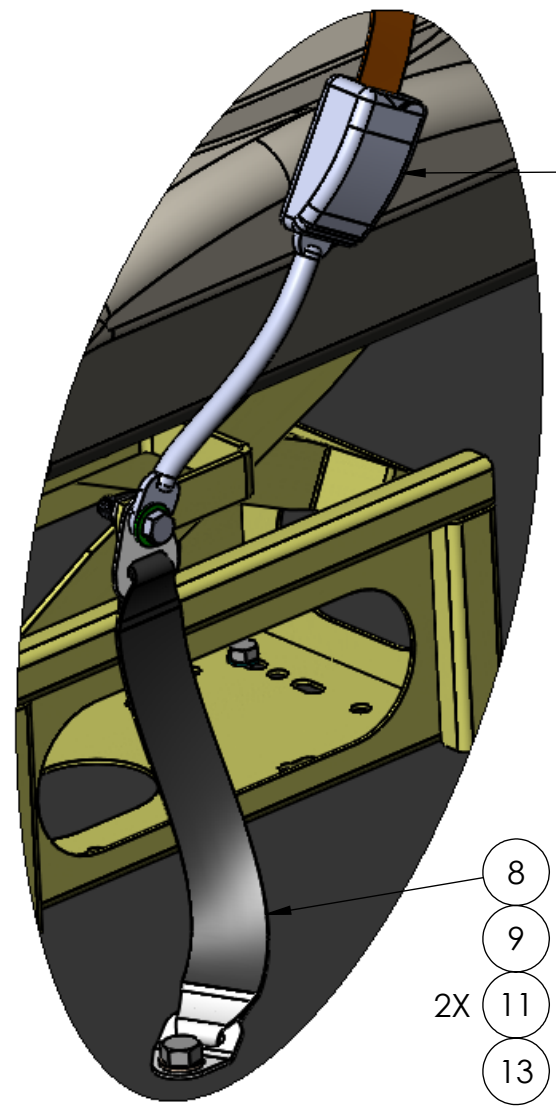

- 7
- 10
- 2X 12
- 14

- 8
- 9
- 2X 11
- 13

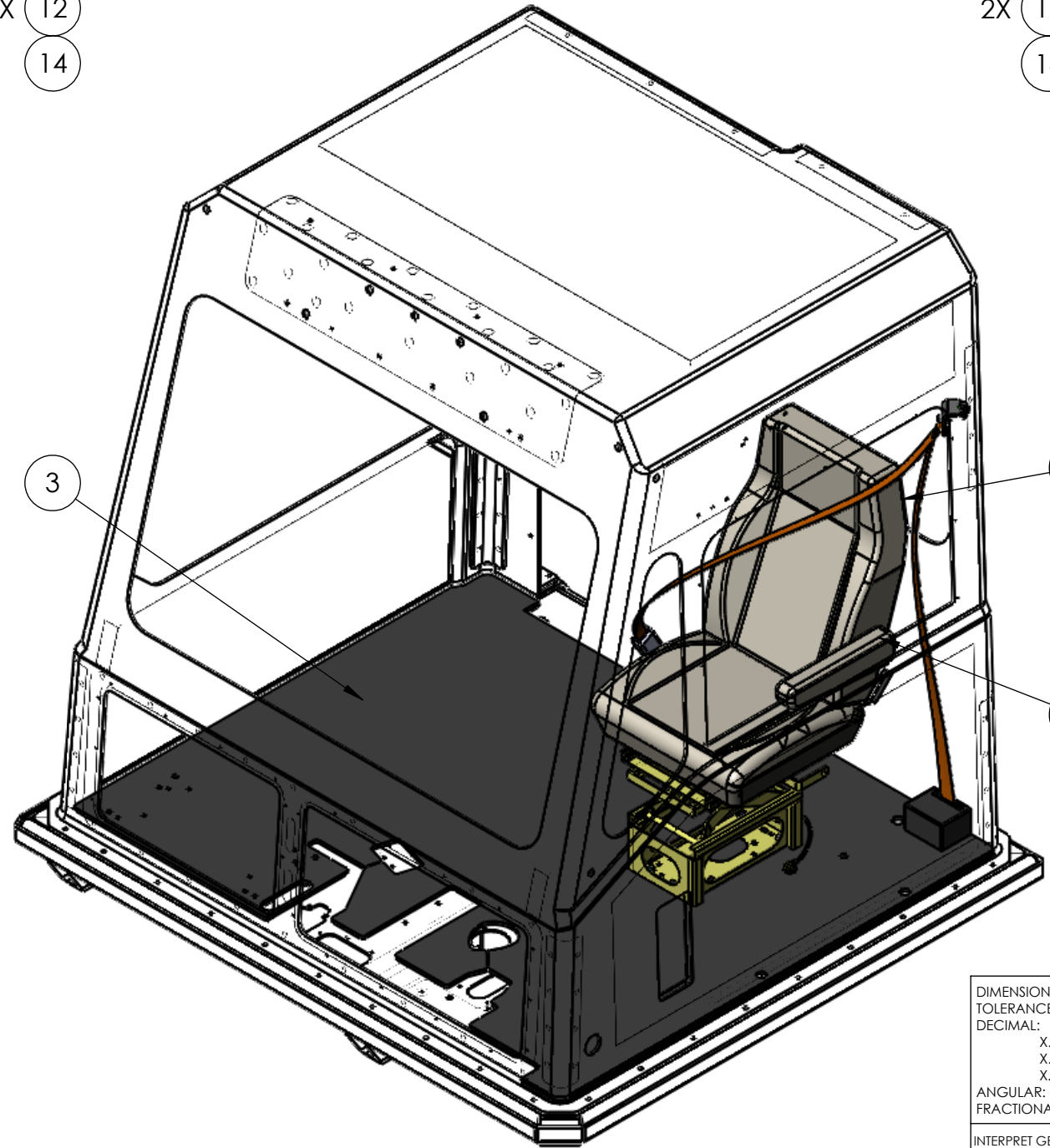

3

- 1
- 4
- 5
- 6
- 2X

2

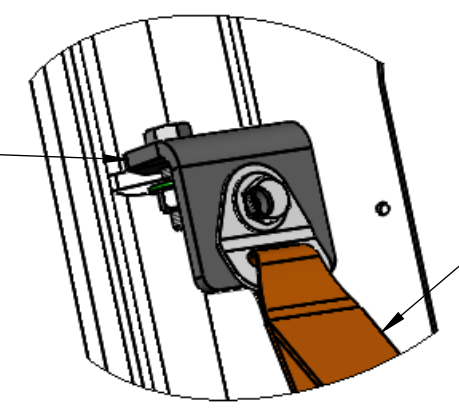

- 15
- 16
- 2X 17
- 18

- 7
- 17
- 19

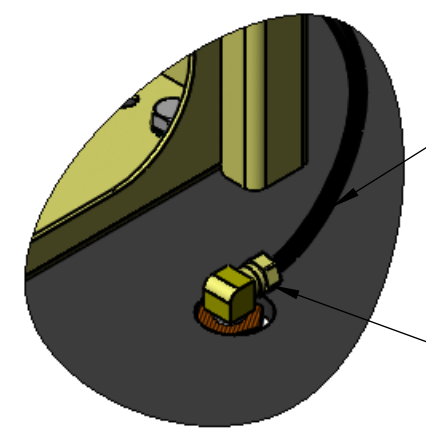

- 22
- 20
- 2X 21

DIMENSIONS ARE IN INCHES TOLERANCES: DECIMAL: X.X ± 0.06 X.XX ± 0.03 X.XXX ± 0.005 ANGULAR: ± 0.5° FRACTIONAL ± 1/32"	NAME	DATE	 TICO/TERMINAL SERVICE 66 CYPRESS RIDGE DR. RIDGELAND, SC 29936 (843) 717-2226		
	DRAWN	MPC		01/31/2018	
	CHECKED	---		---	
	APPROVED	---		---	
INTERPRET GEOMETRIC TOLERANCING PER: ASME 14.5M-1994	DO NOT SCALE DRAWING		TITLE: ASSEMBLY, SEAT		
MATERIAL N/A	THE SUBJECT MATTER SHOWN AND DESCRIBED IN THIS DRAWING AND ANY OTHER INFORMATION ADVANCED IN CONNECTION THEREWITH, IS PROPRIETARY PROPERTY AND IS TO BE HELD IN STRICT CONFIDENCE BY YOU. ALL RIGHTS TO ANY INVENTIONS, DESIGNS, TRADE MARKS, TRADE NAMES AND COPYRIGHTS DISCLOSED ARE RESERVED TO TICO TERMINAL SERVICES, INC.		SIZE B		
FINISH N/A			DWG. NO. 721522-C1	REV A	
THICKNESS N/A			SCALE: 1:15	WEIGHT:	SHEET 1 OF 1

8 7 6 5 4 3 2 1

