

**HEADLIGHTS  
PAGE 3**

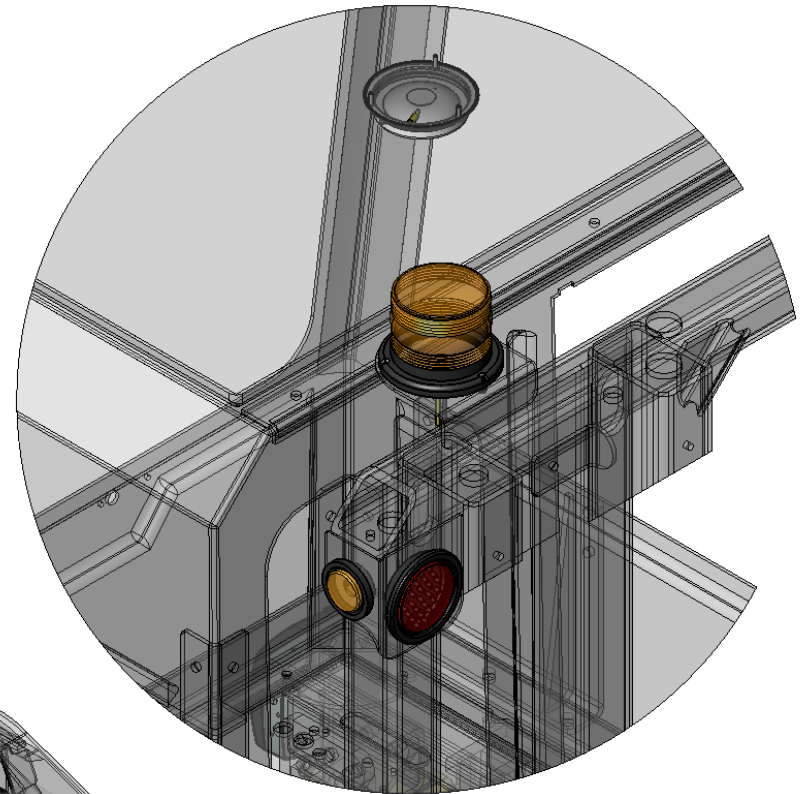

**STROBE, WORK, &  
DOME LIGHTS  
PAGE 2**

DIMENSIONS ARE IN INCHES  
TOLERANCES:  
DECIMAL:  
X.X ± 0.06  
X.XX ± 0.03  
X.XXX ± 0.005  
ANGULAR: ± 0.5°  
FRACTIONAL ± 1/32"

INTERPRET GEOMETRIC TOLERANCING  
PER: ASME 14.5M-1994

MATERIAL

FINISH

THICKNESS

|          | NAME | DATE       |
|----------|------|------------|
| DRAWN    | MPC  | 04/06/2017 |
| CHECKED  |      |            |
| APPROVED |      |            |

DO NOT SCALE DRAWING

THE SUBJECT MATTER SHOWN AND DESCRIBED IN THIS DRAWING AND ANY OTHER INFORMATION ADVANCED IN CONNECTION THEREWITH, IS PROPRIETARY PROPERTY AND IS TO BE HELD IN STRICT CONFIDENCE BY YOU. ALL RIGHTS TO ANY INVENTIONS, DESIGNS, TRADE MARKS, TRADE NAMES AND COPYRIGHTS DISCLOSED ARE RESERVED TO TICO TERMINAL SERVICES, INC.



TICO/TERMINAL SERVICE  
66 CYPRESS RIDGE DR.  
RIDGELAND, SC 29936  
(843) 717-2226

TITLE:

**ASSEMBLY, LIGHTS &  
MOUNTING**

| SIZE     | DWG. NO.  | REV      |
|----------|-----------|----------|
| <b>A</b> | 721479-B1 | <b>B</b> |

SCALE: 1:64 WEIGHT: 4667.47 SHEET 1 OF 3

1 2 3

8 9

4 5

6 7

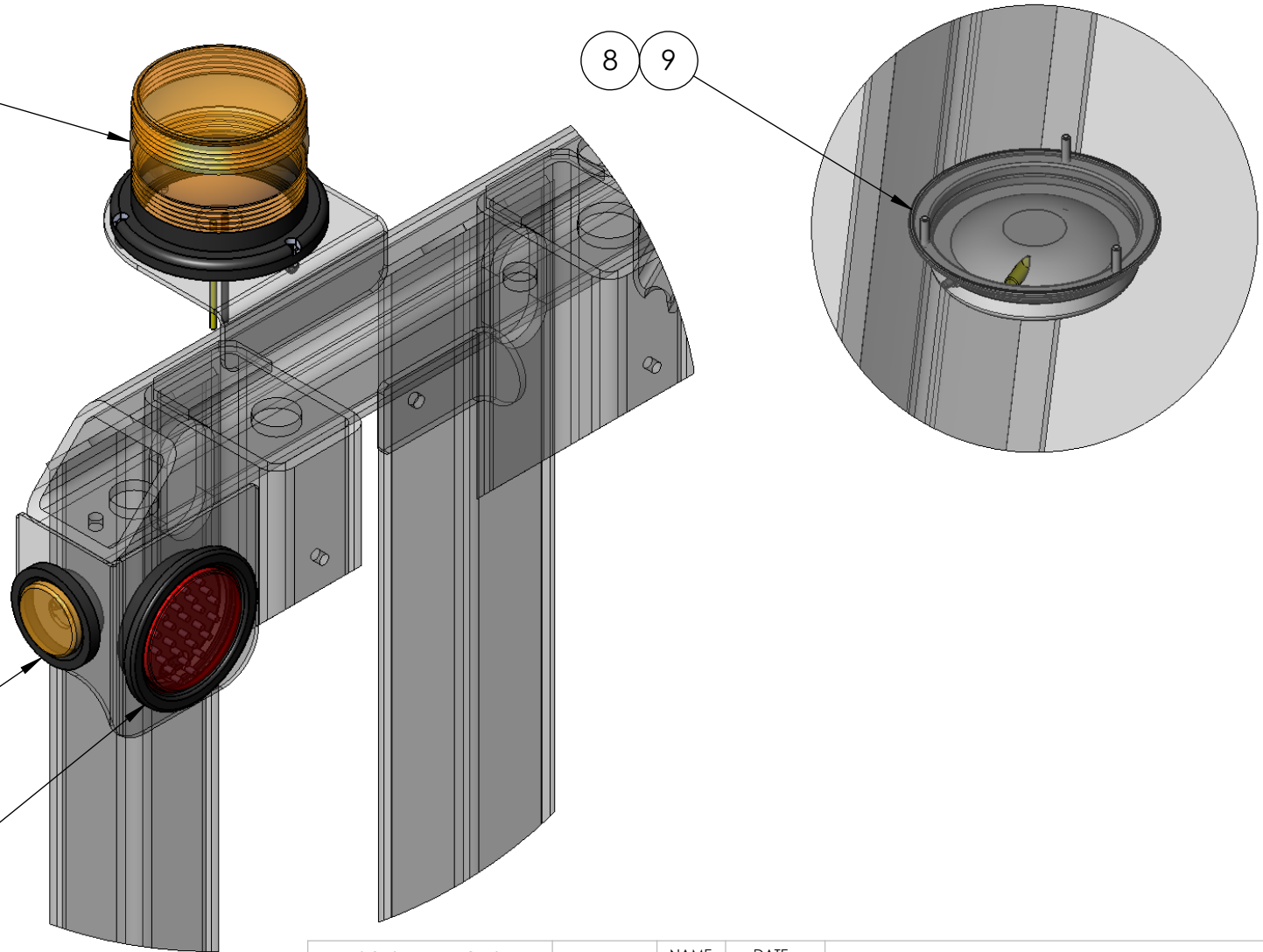

DIMENSIONS ARE IN INCHES  
 TOLERANCES:  
 DECIMAL:  
 X.X ± 0.06  
 X.XX ± 0.03  
 X.XXX ± 0.005  
 ANGULAR: ± 0.5°  
 FRACTIONAL ± 1/32"

INTERPRET GEOMETRIC TOLERANCING  
 PER: ASME 14.5M-1994

MATERIAL

FINISH

THICKNESS

|          | NAME | DATE       |
|----------|------|------------|
| DRAWN    | MPC  | 04/06/2017 |
| CHECKED  |      |            |
| APPROVED |      |            |

DO NOT SCALE DRAWING

THE SUBJECT MATTER SHOWN AND DESCRIBED IN THIS DRAWING AND ANY OTHER INFORMATION ADVANCED IN CONNECTION THEREWITH, IS PROPRIETARY PROPERTY AND IS TO BE HELD IN STRICT CONFIDENCE BY YOU. ALL RIGHTS TO ANY INVENTIONS, DESIGNS, TRADE MARKS, TRADE NAMES AND COPYRIGHTS DISCLOSED ARE RESERVED TO TICO TERMINAL SERVICES, INC.

**TICO**  TICO/TERMINAL SERVICE  
 66 CYPRESS RIDGE DR.  
 RIDGELAND, SC 29936  
 (843) 717-2226

TITLE:  
**ASSEMBLY, LIGHTS & MOUNTING**

|                  |                       |                 |
|------------------|-----------------------|-----------------|
| SIZE<br><b>A</b> | DWG. NO.<br>721479-B1 | REV<br><b>B</b> |
|------------------|-----------------------|-----------------|

SCALE: 1:64 WEIGHT: 4667.47 SHEET 2 OF 3

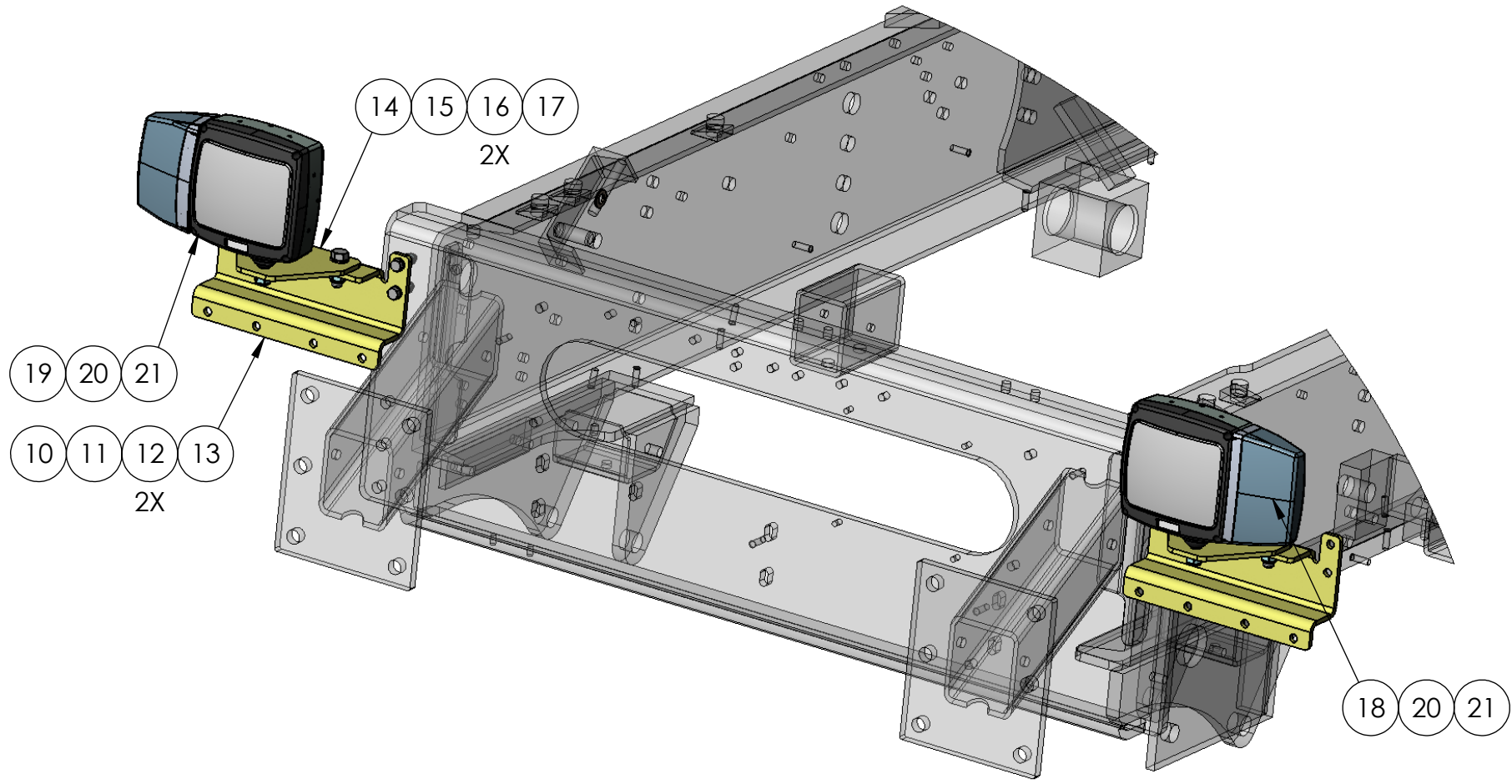

DIMENSIONS ARE IN INCHES  
 TOLERANCES:  
 DECIMAL:  
 X.X ± 0.06  
 X.XX ± 0.03  
 X.XXX ± 0.005  
 ANGULAR: ± 0.5°  
 FRACTIONAL ± 1/32"

INTERPRET GEOMETRIC TOLERANCING PER: ASME 14.5M-1994

MATERIAL

FINISH

THICKNESS

|   | NAME | DATE       |
|---|------|------------|
| DRAWN   | MPC  | 04/06/2017 |
| CHECKED   |      |            |
| APPROVED  |      |            |
| DO NOT SCALE DRAWING  |      |            |
| THE SUBJECT MATTER SHOWN AND DESCRIBED IN THIS DRAWING AND ANY OTHER INFORMATION ADVANCED IN CONNECTION THEREWITH, IS PROPRIETARY PROPERTY AND IS TO BE HELD IN STRICT CONFIDENCE BY YOU. ALL RIGHTS TO ANY INVENTIONS, DESIGNS, TRADE MARKS, TRADE NAMES AND COPYRIGHTS DISCLOSED ARE RESERVED TO TICO TERMINAL SERVICES, INC. |      |            |

|   |           |  |
|---|-----------|--|
|  |           | TICO/TERMINAL SERVICE<br>66 CYPRESS RIDGE DR.<br>RIDGELAND, SC 29936<br>(843) 717-2226 |
| TITLE:  |           |  |
| <b>ASSEMBLY, LIGHTS &amp; MOUNTING</b>  |           |  |
| SIZE  | DWG. NO.  | REV  |
| <b>A</b>  | 721479-B1 | <b>B</b>   |
| SCALE: 1:64 WEIGHT: 4667.47 SHEET 3 OF 3  |           |  |

