

**AIR DRYER MAIN VIEW
PAGE 2**

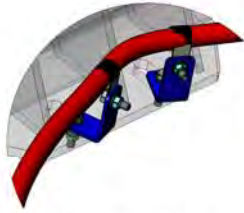

**SUPPORT VIEW TYPICAL
PAGE 2**

DIMENSIONS ARE IN INCHES		NAME	DATE	 TICO/TERMINAL SERVICE 66 CYPRESS RIDGE DR. RIDGELAND, SC 29936 (843) 717-2226	
TOLERANCES:		DRAWN	MAL		01/30/2017
DECIMAL:		CHECKED			
.XX ± 0.06 .XXX ± 0.03 .XXXX ± 0.005 ANGULAR: ± 0.5° FRACTIONAL: ± 1/32"		APPROVED			
INTERPRET GEOMETRIC TOLERANCING PER: ASME Y14.5M-1994		DO NOT SCALE DRAWING			TITLE:
MATERIAL: N/A		THE SUBJECT MATTER SHOWN AND DESCRIBED IN THIS DRAWING AND ANY OTHER INFORMATION ADVANCED IN CONNECTION THEREWITH IS PROPRIETARY PROPERTY AND IS TO BE HELD IN STRICT CONFIDENCE BY YOU. ALL RIGHTS TO ANY INVENTIONS, DESIGN, TRADE MARKS, TRADE NAMES AND COPYRIGHTS DECLARED ARE RESERVED TO TICO TERMINAL SERVICES, INC.			AIR DRYER, BENDIX ADIP, PSI ENGINE
FINISH: SEE NOTE		SIZE			DWG. NO.
THICKNESS: N/A		C			721468-C1
		SCALE: 1:32			WEIGHT: 2548.10
					SHEET 1 OF 1

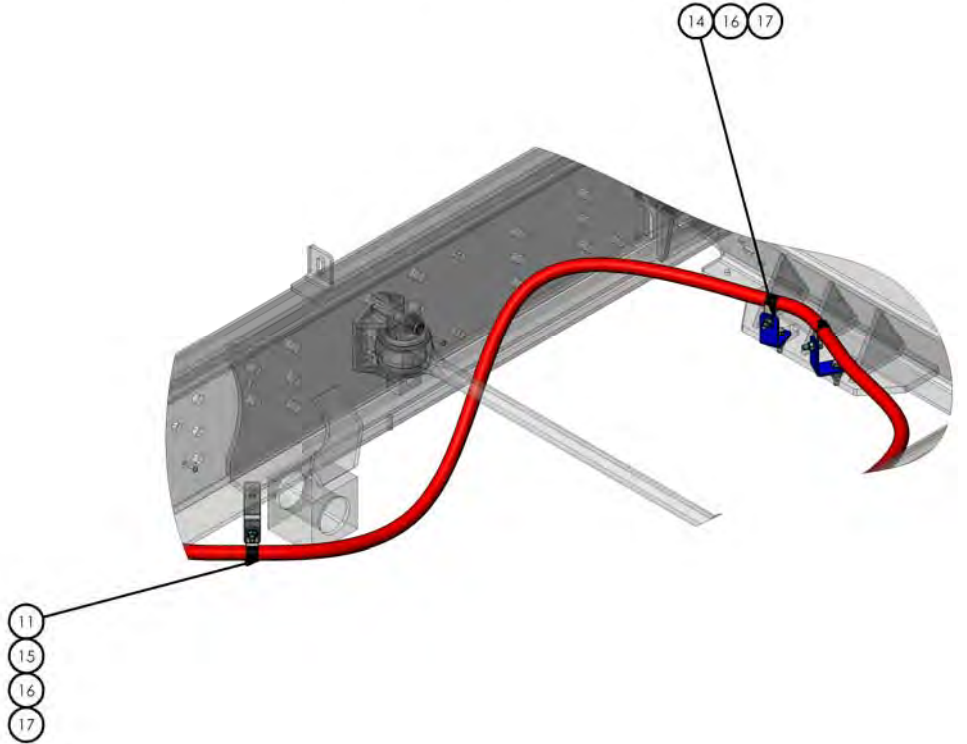
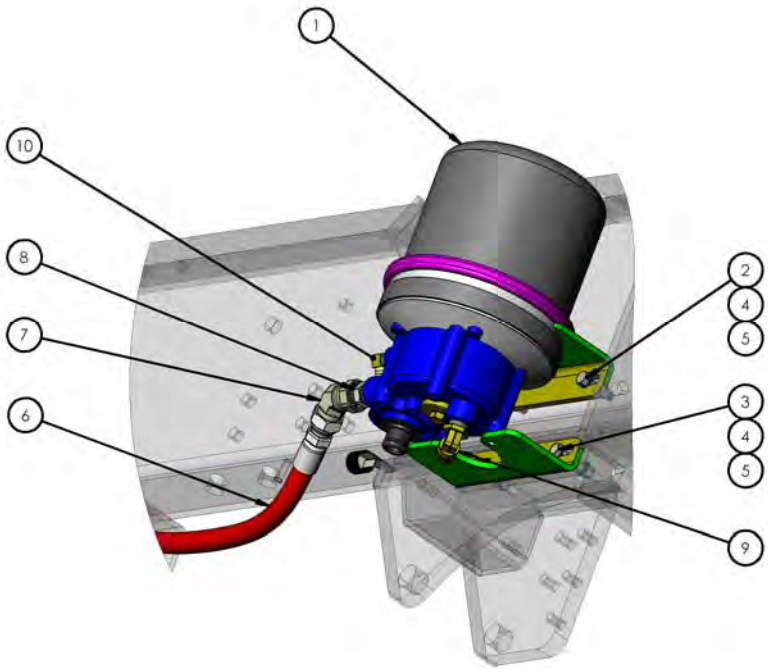

DIMENSIONS ARE IN INCHES		NAME	DATE
TOLERANCES:		DRAWN	MAL 01/30/2017
DECIMAL:		CHECKED	
XX	± 0.06	APPROVED	
XXX	± 0.03	DO NOT SCALE DRAWING	
XXXX	± 0.005	THE SUBJECT MATTER SHOWN AND DESCRIBED IN THIS DRAWING AND ANY OTHER INFORMATION ADVANCED IN CONNECTION THEREWITH IS TO BE HELD IN STRICT CONFIDENCE BY YOU. ALL RIGHTS TO ANY INVENTIONS, DESIGN, TRADE MARKS, TRADE NAME AND COPYRIGHTS DECLARED ARE RESERVED TO TICO TERMINAL SERVICES, INC.	
ANGULAR:	± 0.5°	TICO/TERRMINAL SERVICE 66 CYPRESS RIDGE DR. RIDGELAND, SC 29936 (843) 717-2226	
FRACTIONAL:	1/32"	TITLE: AIR DRYER, BENDIX ADIP PSI ENGINE	
INTERPRET GEOMETRIC TOLERANCING PER: ASME Y14.5M-1994		SIZE	DWG. NO.
MATERIAL	N/A	C	721468-C1
FINISH	SEE NOTE	REV	
THICKNESS	N/A	SCALE: 1:32 WEIGHT: 2548.10 SHEET 1 OF 1	

