

DIMENSIONS ARE IN INCHES		NAME	DATE	 TICO MANUFACTURING 66 CYPRESS RIDGE DR. RIDGELAND, SC 29936 (843) 717-2226
TOLERANCES:		DRAWN	MPC 09/19/2017	
DECIMAL:		CHECKED		
X.X ± 0.06 X.XX ± 0.03 X.XXX ± 0.005		APPROVED		
ANGULAR:		DO NOT SCALE DRAWING		TITLE: ASSEMBLY, HYDRAULIC SYSTEM
FRACTIONAL ± 1/32"		THE SUBJECT MATTER SHOWN AND DESCRIBED IN THIS DRAWING AND ANY OTHER INFORMATION ADVANCED IN CONNECTION THEREWITH, IS PROPRIETARY PROPERTY AND IS TO BE HELD IN STRICT CONFIDENCE BY YOU. ALL RIGHTS TO ANY INVENTIONS, DESIGNS, TRADE MARKS, TRADE NAMES AND COPYRIGHTS DISCLOSED ARE RESERVED TO TICO TERMINAL SERVICES, INC.		SIZE B DWG. NO. 721420-A1 REV A
MATERIAL				SCALE: 1:11
FINISH				WEIGHT:
THICKNESS				SHEET 1 OF 4

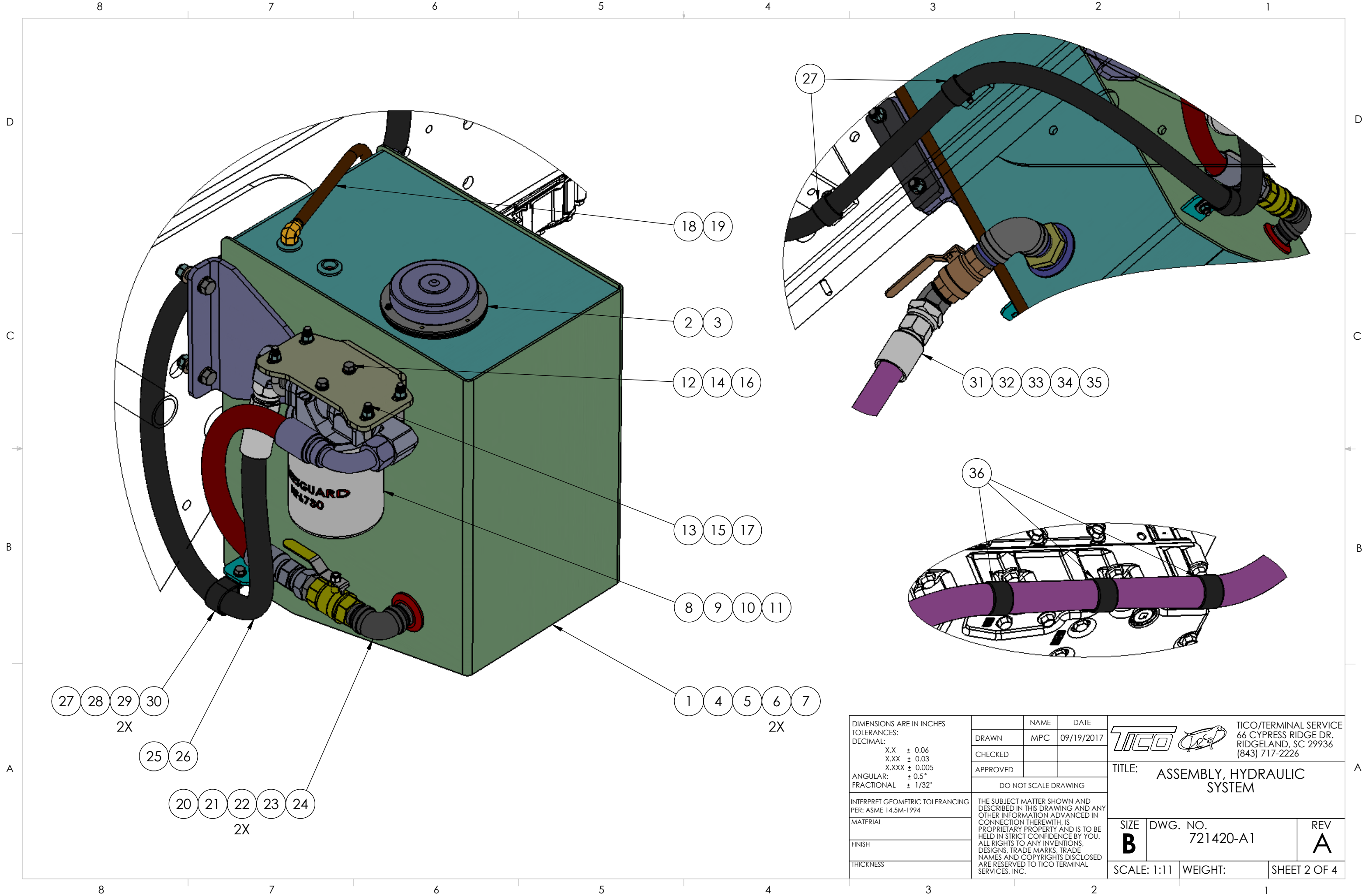

DIMENSIONS ARE IN INCHES
 TOLERANCES:
 DECIMAL:
 X.X ± 0.06
 X.XX ± 0.03
 X.XXX ± 0.005
 ANGULAR:
 ± 0.5°
 FRACTIONAL ± 1/32"

INTERPRET GEOMETRIC TOLERANCING PER: ASME 14.5M-1994

MATERIAL

FINISH

THICKNESS

	NAME	DATE
DRAWN	MPC	09/19/2017
CHECKED		
APPROVED		

TICO  TICO/TERMINAL SERVICE
 66 CYPRESS RIDGE DR.
 RIDGELAND, SC 29936
 (843) 717-2226

TITLE: ASSEMBLY, HYDRAULIC SYSTEM

SIZE B	DWG. NO. 721420-A1	REV A
------------------	-----------------------	-----------------

SCALE: 1:11 WEIGHT: SHEET 2 OF 4

DO NOT SCALE DRAWING

THE SUBJECT MATTER SHOWN AND DESCRIBED IN THIS DRAWING AND ANY OTHER INFORMATION ADVANCED IN CONNECTION THEREWITH, IS PROPRIETARY PROPERTY AND IS TO BE HELD IN STRICT CONFIDENCE BY YOU. ALL RIGHTS TO ANY INVENTIONS, DESIGNS, TRADE MARKS, TRADE NAMES AND COPYRIGHTS DISCLOSED ARE RESERVED TO TICO TERMINAL SERVICES, INC.

8 7 6 5 4 3 2 1

D
C
B
A

D
C
B
A

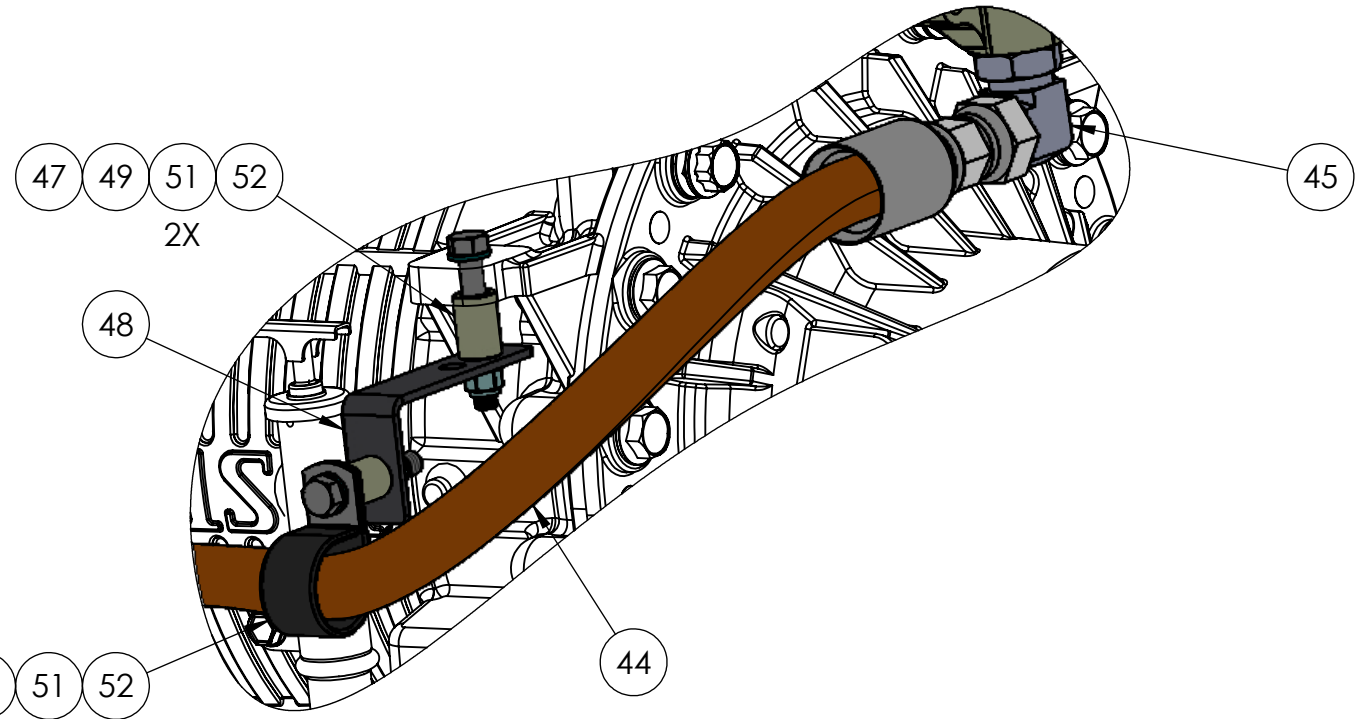
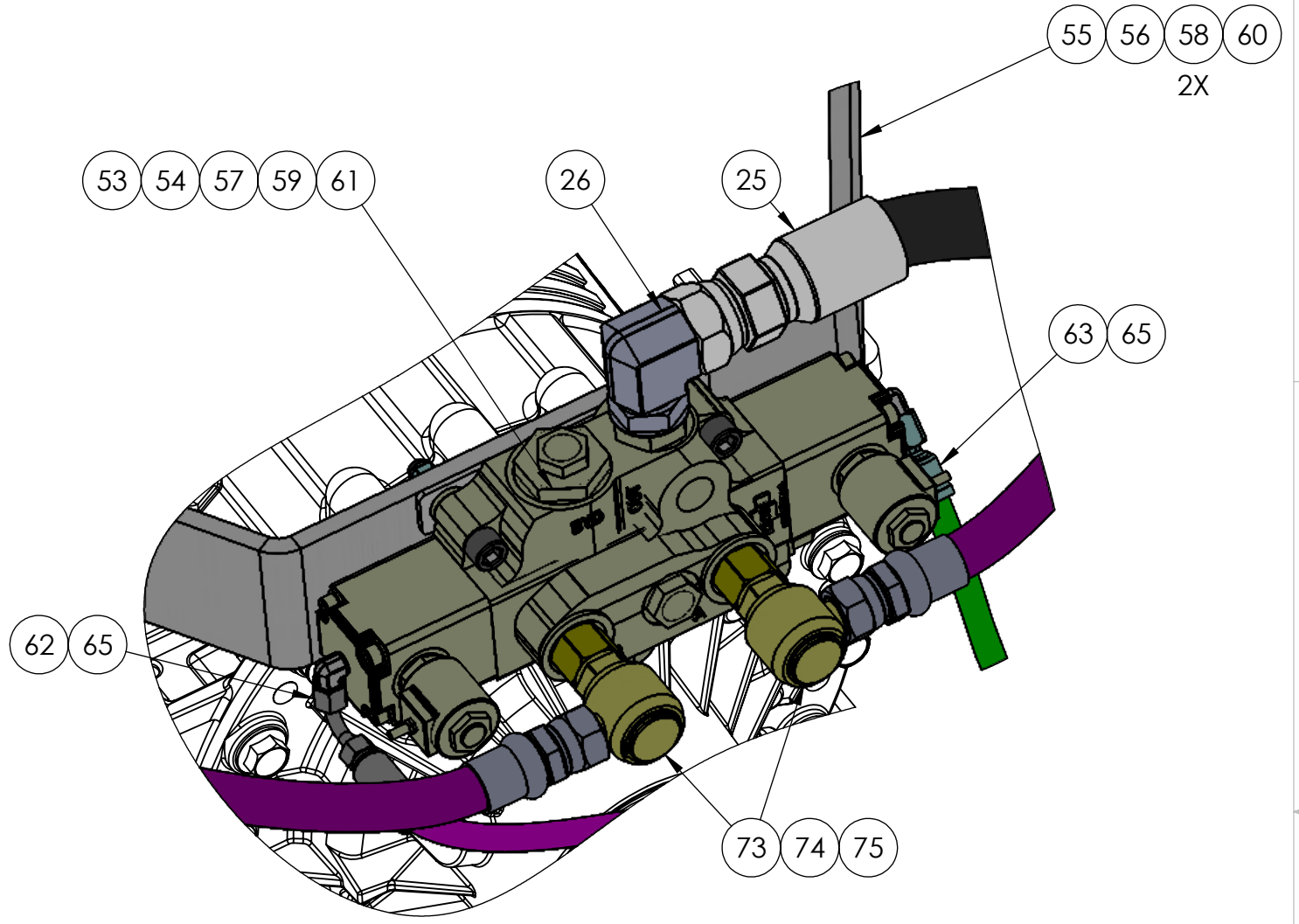
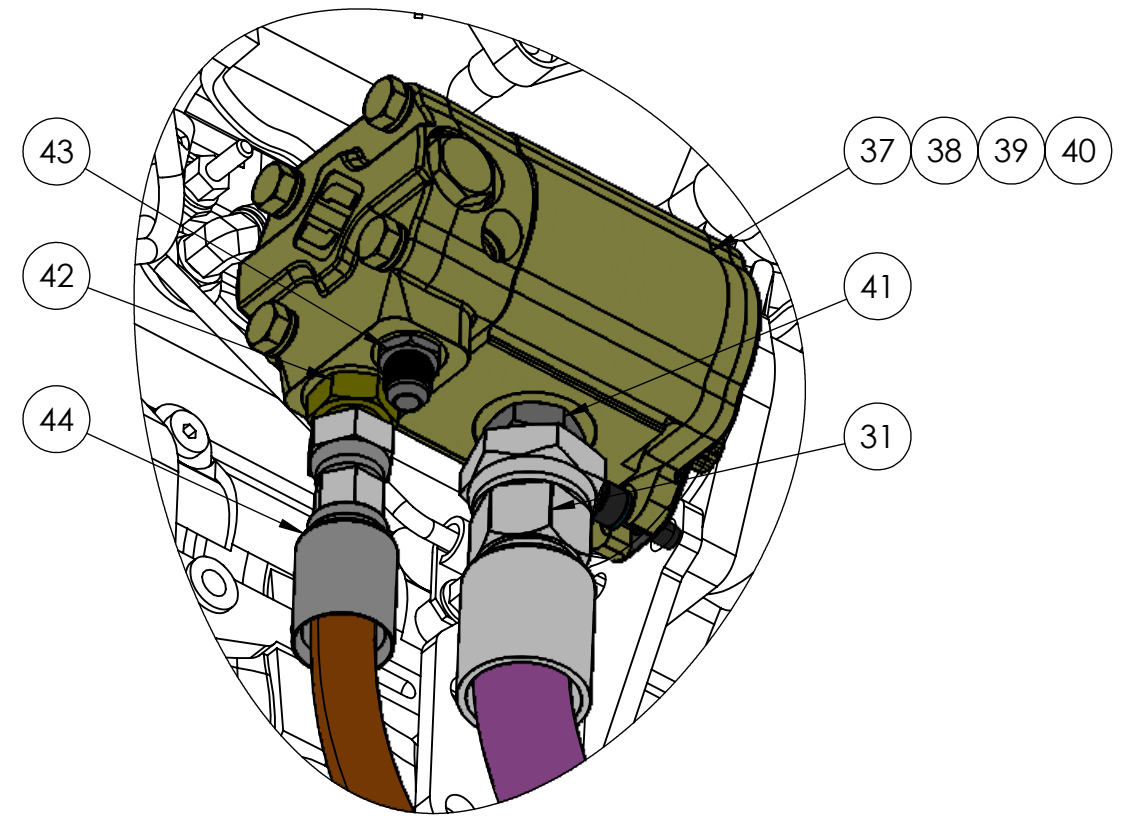

46 47 50 51 52
2X

DIMENSIONS ARE IN INCHES TOLERANCES: DECIMAL: X.X ± 0.06 X.XX ± 0.03 X.XXX ± 0.005 ANGULAR: ± 0.5° FRACTIONAL ± 1/32"	DRAWN MPC	NAME MPC	DATE 09/19/2017	TICO/TERMINAL SERVICE 66 CYPRESS RIDGE DR. RIDGELAND, SC 29936 (843) 717-2226
	CHECKED			
	APPROVED			
	DO NOT SCALE DRAWING			
INTERPRET GEOMETRIC TOLERANCING PER: ASME 14.5M-1994	THE SUBJECT MATTER SHOWN AND DESCRIBED IN THIS DRAWING AND ANY OTHER INFORMATION ADVANCED IN CONNECTION THEREWITH, IS PROPRIETARY PROPERTY AND IS TO BE HELD IN STRICT CONFIDENCE BY YOU. ALL RIGHTS TO ANY INVENTIONS, DESIGNS, TRADE MARKS, TRADE NAMES AND COPYRIGHTS DISCLOSED ARE RESERVED TO TICO TERMINAL SERVICES, INC.			TITLE: ASSEMBLY, HYDRAULIC SYSTEM
MATERIAL	SIZE B	DWG. NO. 721420-A1	REV A	SCALE: 1:11
FINISH	WEIGHT:	SHEET 3 OF 4		
THICKNESS				

8 7 6 5 4 3 2 1

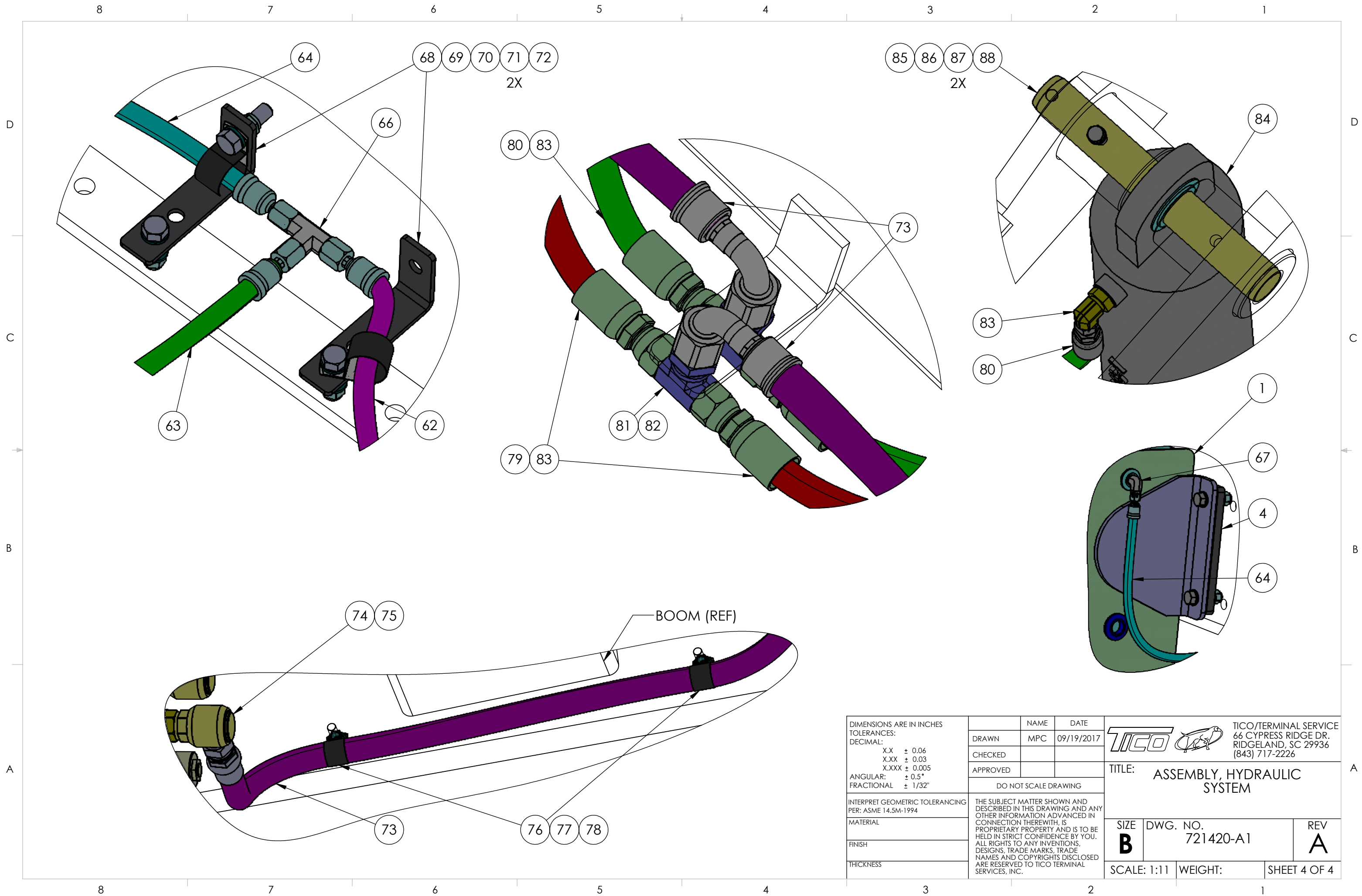

DIMENSIONS ARE IN INCHES TOLERANCES: DECIMAL: X.X ± 0.06 X.XX ± 0.03 X.XXX ± 0.005 ANGULAR: ± 0.5° FRACTIONAL ± 1/32"	DRAWN	NAME	DATE
	CHECKED	MPC	09/19/2017
	APPROVED		
	DO NOT SCALE DRAWING		
INTERPRET GEOMETRIC TOLERANCING PER: ASME 14.5M-1994	THE SUBJECT MATTER SHOWN AND DESCRIBED IN THIS DRAWING AND ANY OTHER INFORMATION ADVANCED IN CONNECTION THEREWITH, IS PROPRIETARY PROPERTY AND IS TO BE HELD IN STRICT CONFIDENCE BY YOU. ALL RIGHTS TO ANY INVENTIONS, DESIGNS, TRADE MARKS, TRADE NAMES AND COPYRIGHTS DISCLOSED ARE RESERVED TO TICO TERMINAL SERVICES, INC.		
MATERIAL			
FINISH			
THICKNESS			
TICO  TICO/TERMINAL SERVICE 66 CYPRESS RIDGE DR. RIDGELAND, SC 29936 (843) 717-2226		TITLE: ASSEMBLY, HYDRAULIC SYSTEM	
SIZE B	DWG. NO. 721420-A1	REV A	
SCALE: 1:11	WEIGHT:	SHEET 4 OF 4	

