

8 7 6 5 4 3 2 1

D  
C  
B  
A

D  
C  
B  
A

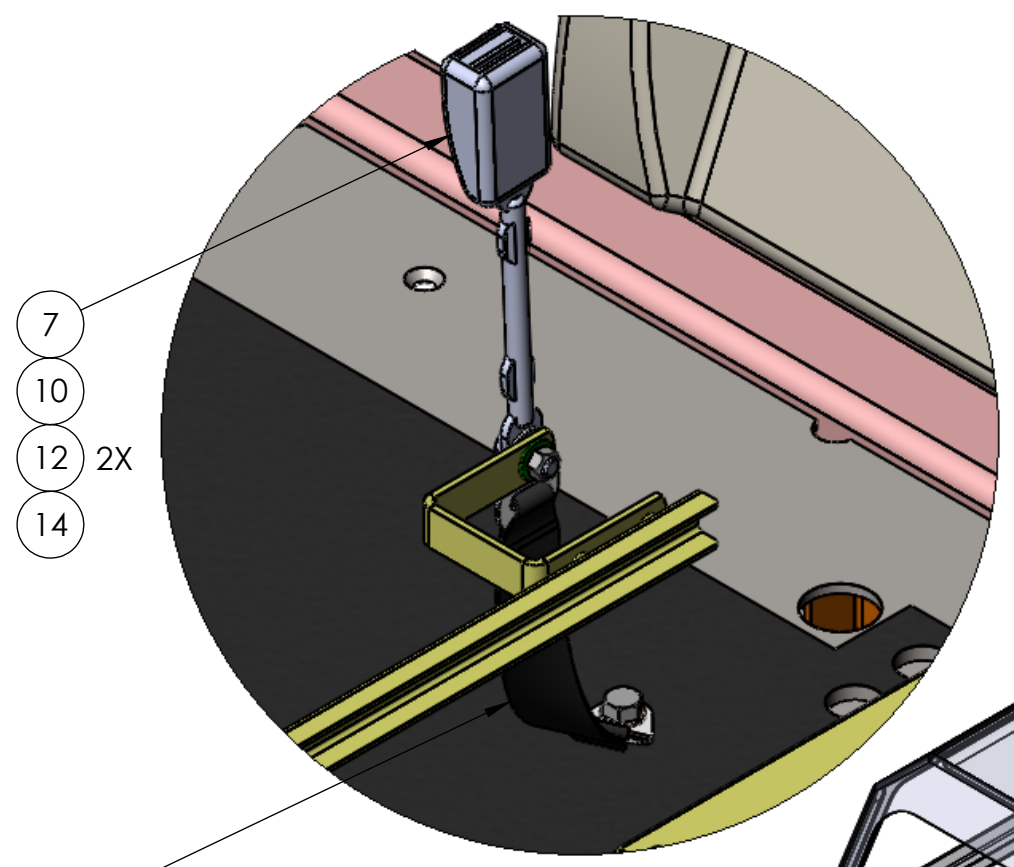

**SEAT BELT & TETHER**

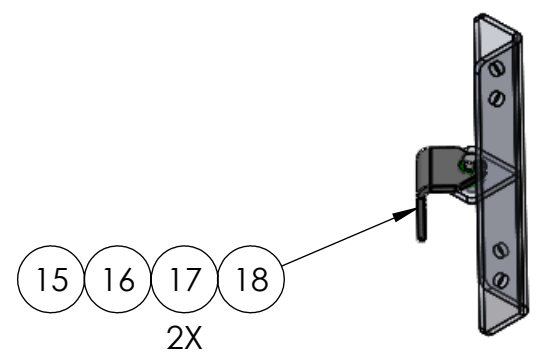

**SHOULDER STRAP**

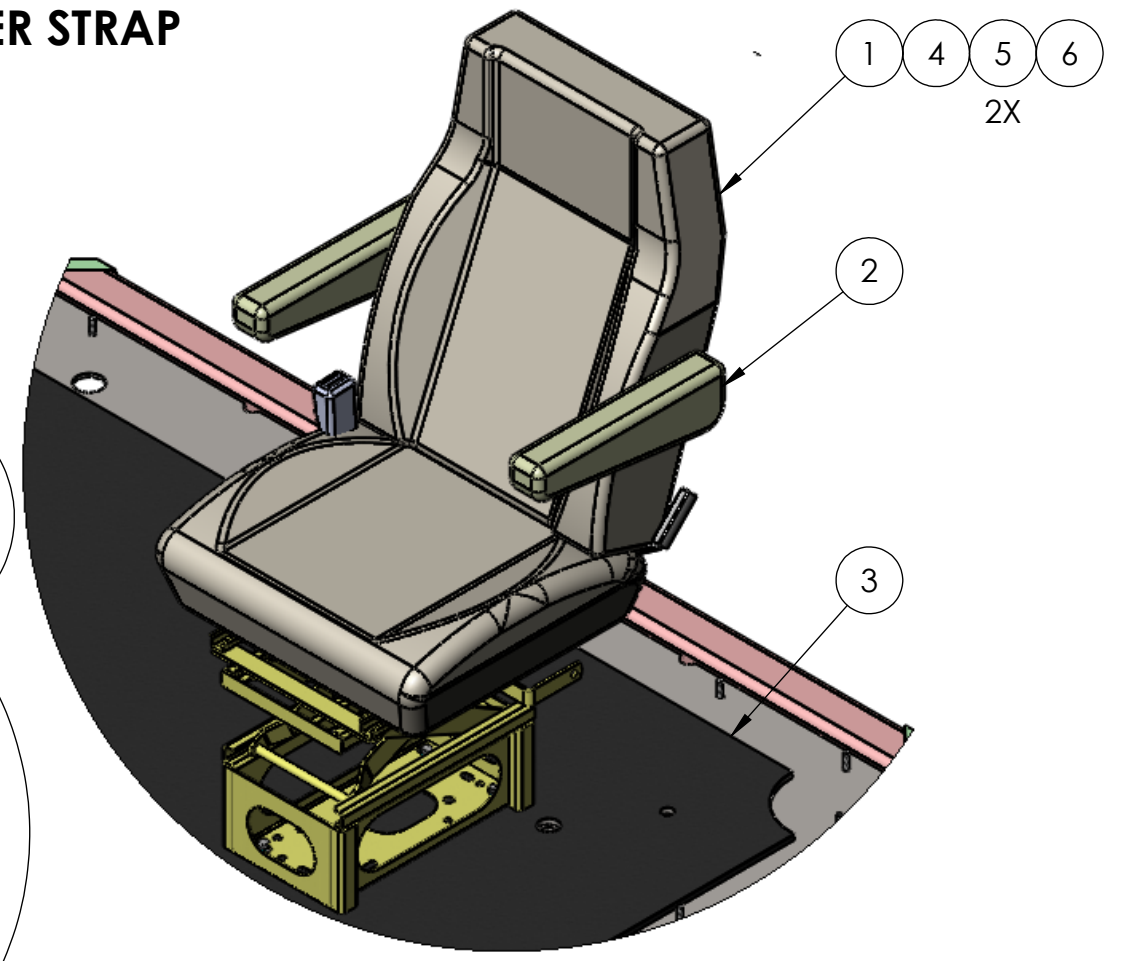
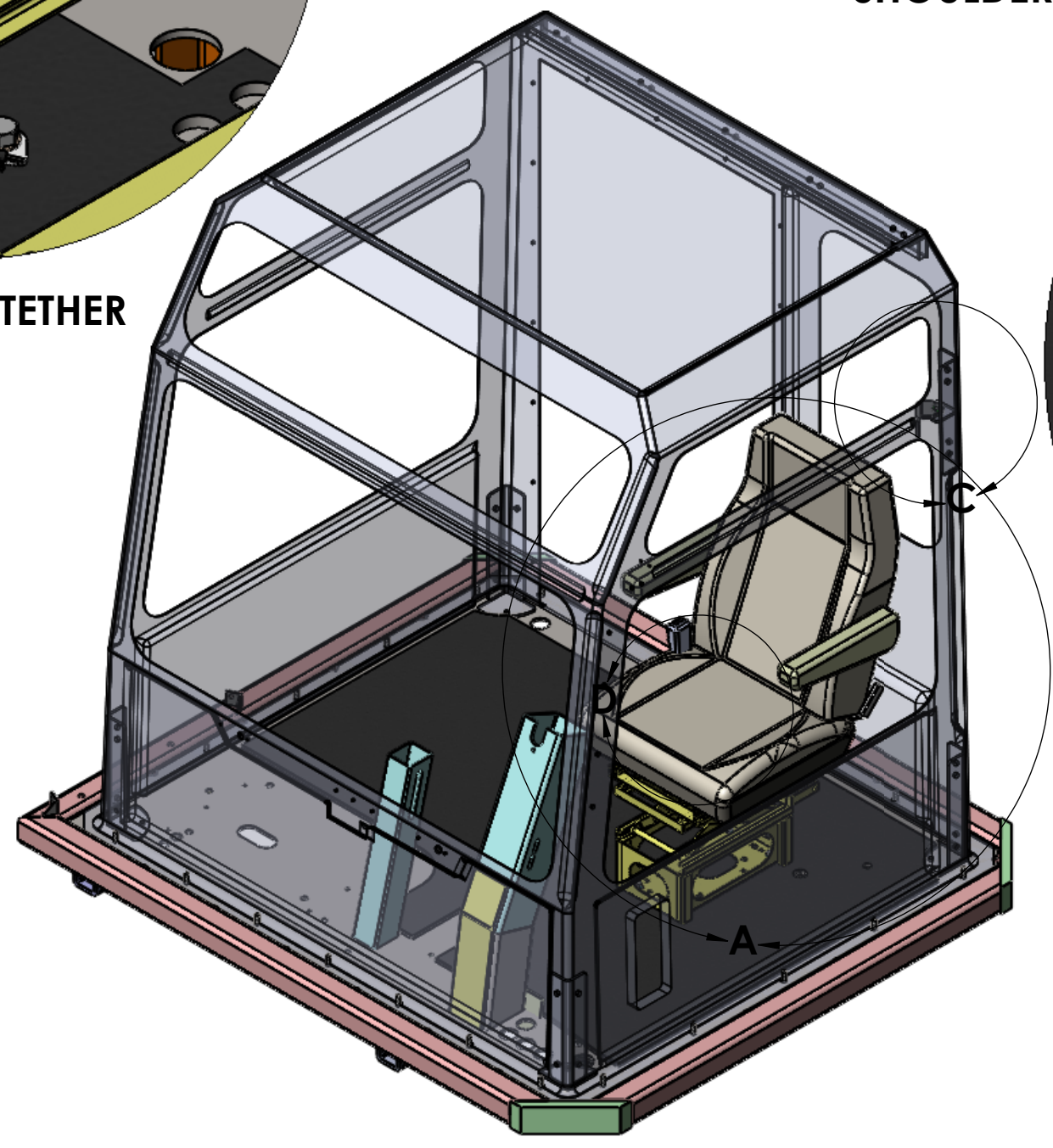

**SEAT & FLOOR**

DIMENSIONS ARE IN INCHES TOLERANCES: DECIMAL: X.X ± 0.06 X.XX ± 0.03 X.XXX ± 0.005 ANGULAR: ± 0.5° FRACTIONAL ± 1/32"	NAME	DATE	 TICO MANUFACTURING 66 CYPRESS RIDGE DR. RIDGELAND, SC 29936 (843) 717-2226	
	DRAWN	MPC		04/10/2017
	CHECKED			
	APPROVED			
DO NOT SCALE DRAWING			TITLE: ASSEMBLY, SEAT, BOSTROM	
MATERIAL	THE SUBJECT MATTER SHOWN AND DESCRIBED IN THIS DRAWING AND ANY OTHER INFORMATION ADVANCED IN CONNECTION THEREWITH, IS PROPRIETARY PROPERTY AND IS TO BE HELD IN STRICT CONFIDENCE BY YOU. ALL RIGHTS TO ANY INVENTIONS, DESIGNS, TRADE MARKS, TRADE NAMES AND COPYRIGHTS DISCLOSED ARE RESERVED TO TICO TERMINAL SERVICES, INC.		SIZE	
FINISH			DWG. NO.	
THICKNESS			721403-C1	
			REV	
	SCALE: 1:32	WEIGHT: 1389.68	SHEET 1 OF 1	

8 7 6 5 4 3 2 1

