

**HEADLIGHTS
PAGE 3**

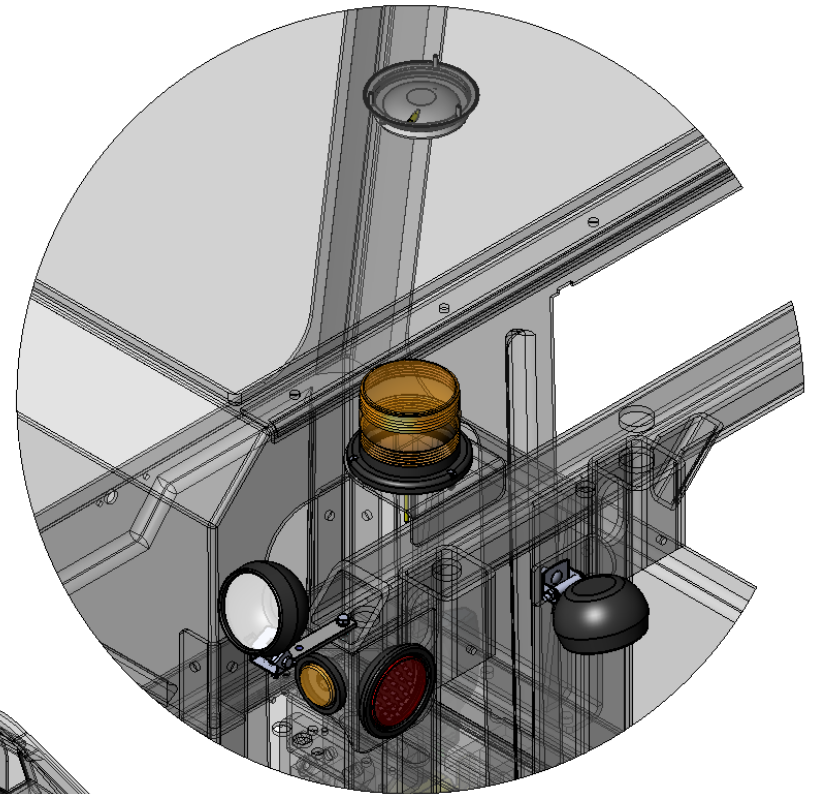

**STROBE, WORK, &
DOME LIGHTS
PAGE 2**

DIMENSIONS ARE IN INCHES	
TOLERANCES:	
DECIMAL:	
X.X	± 0.06
X.XX	± 0.03
X.XXX	± 0.005
ANGULAR:	
	± 0.5°
FRACTIONAL:	
	± 1/32"
INTERPRET GEOMETRIC TOLERANCING PER: ASME 14.5M-1994	
MATERIAL	
FINISH	
THICKNESS	

	NAME	DATE
DRAWN	MPC	03/14/2017
CHECKED		
APPROVED		
DO NOT SCALE DRAWING		
THE SUBJECT MATTER SHOWN AND DESCRIBED IN THIS DRAWING AND ANY OTHER INFORMATION ADVANCED IN CONNECTION THEREWITH, IS PROPRIETARY PROPERTY AND IS TO BE HELD IN STRICT CONFIDENCE BY YOU. ALL RIGHTS TO ANY INVENTIONS, DESIGNS, TRADE MARKS, TRADE NAMES AND COPYRIGHTS DISCLOSED ARE RESERVED TO TICO TERMINAL SERVICES, INC.		

		TICO/TERMINAL SERVICE 66 CYPRESS RIDGE DR. RIDGELAND, SC 29936 (843) 717-2226	
TITLE:			
ASSEMBLY, LIGHTS & MOUNTING			
SIZE	DWG. NO.	REV	
A	721386-B1	B	
SCALE: 1:64 WEIGHT: 4593.46 SHEET 1 OF 3			

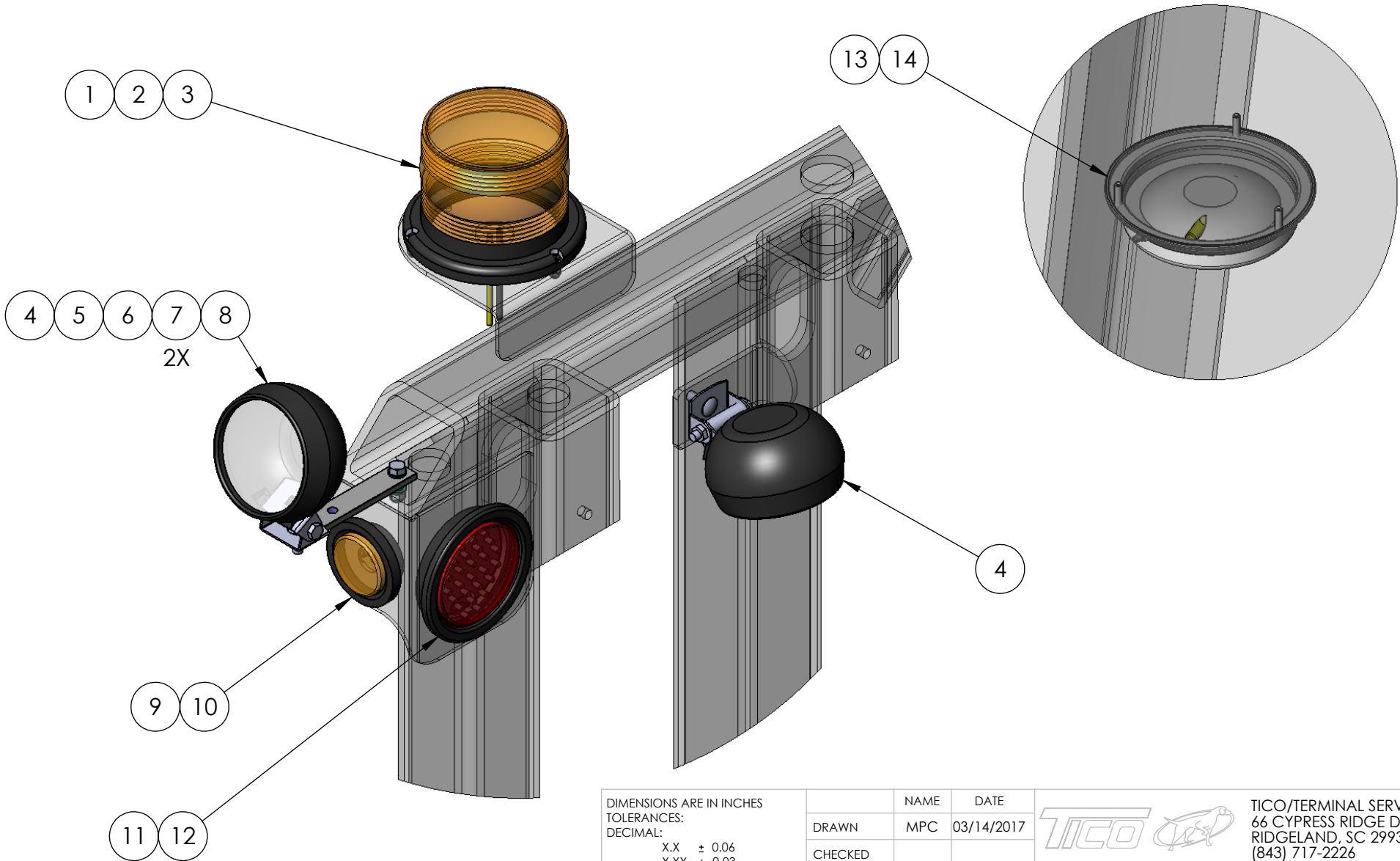

DIMENSIONS ARE IN INCHES

TOLERANCES:
DECIMAL:

X.X ± 0.06
X.XX ± 0.03
X.XXX ± 0.005

ANGULAR: ± 0.5°
FRACTIONAL ± 1/32"

INTERPRET GEOMETRIC TOLERANCING
PER: ASME 14.5M-1994

MATERIAL

FINISH

THICKNESS

	NAME	DATE
DRAWN	MPC	03/14/2017
CHECKED		
APPROVED		

DO NOT SCALE DRAWING

THE SUBJECT MATTER SHOWN AND DESCRIBED IN THIS DRAWING AND ANY OTHER INFORMATION ADVANCED IN CONNECTION THEREWITH, IS PROPRIETARY PROPERTY AND IS TO BE HELD IN STRICT CONFIDENCE BY YOU. ALL RIGHTS TO ANY INVENTIONS, DESIGNS, TRADE MARKS, TRADE NAMES AND COPYRIGHTS DISCLOSED ARE RESERVED TO TICO TERMINAL SERVICES, INC.



TICO/TERMINAL SERVICE
66 CYPRESS RIDGE DR.
RIDGELAND, SC 29936
(843) 717-2226

TITLE:
ASSEMBLY, LIGHTS & MOUNTING

SIZE	DWG. NO.	REV
A	721386-B1	B

SCALE: 1:64 WEIGHT: 4593.46 SHEET 2 OF 3

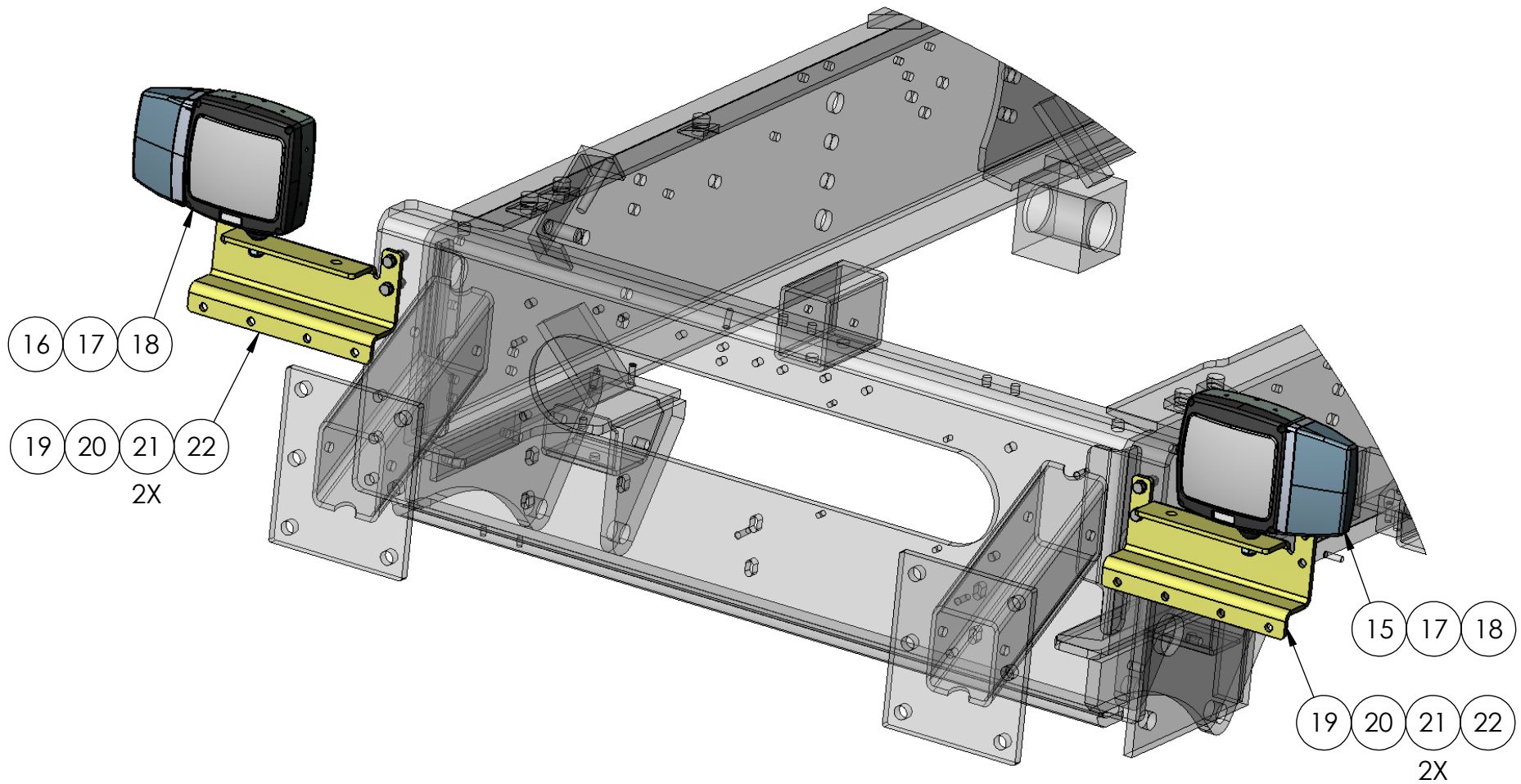

DIMENSIONS ARE IN INCHES	
TOLERANCES:	
DECIMAL:	
X.X	± 0.06
X.XX	± 0.03
X.XXX	± 0.005
ANGULAR: ± 0.5°	
FRACTIONAL ± 1/32"	
INTERPRET GEOMETRIC TOLERANCING PER: ASME 14.5M-1994	
MATERIAL	
FINISH	
THICKNESS	

	NAME	DATE
DRAWN	MPC	03/14/2017
CHECKED		
APPROVED		
DO NOT SCALE DRAWING		
THE SUBJECT MATTER SHOWN AND DESCRIBED IN THIS DRAWING AND ANY OTHER INFORMATION ADVANCED IN CONNECTION THEREWITH, IS PROPRIETARY PROPERTY AND IS TO BE HELD IN STRICT CONFIDENCE BY YOU. ALL RIGHTS TO ANY INVENTIONS, DESIGNS, TRADE MARKS, TRADE NAMES AND COPYRIGHTS DISCLOSED ARE RESERVED TO TICO TERMINAL SERVICES, INC.		

		TICO/TERMINAL SERVICE 66 CYPRESS RIDGE DR. RIDGELAND, SC 29936 (843) 717-2226	
TITLE:			
ASSEMBLY, LIGHTS & MOUNTING			
SIZE	DWG. NO.	REV	
A	721386-B1	B	
SCALE: 1:64 WEIGHT: 4593.46 SHEET 3 OF 3			

