

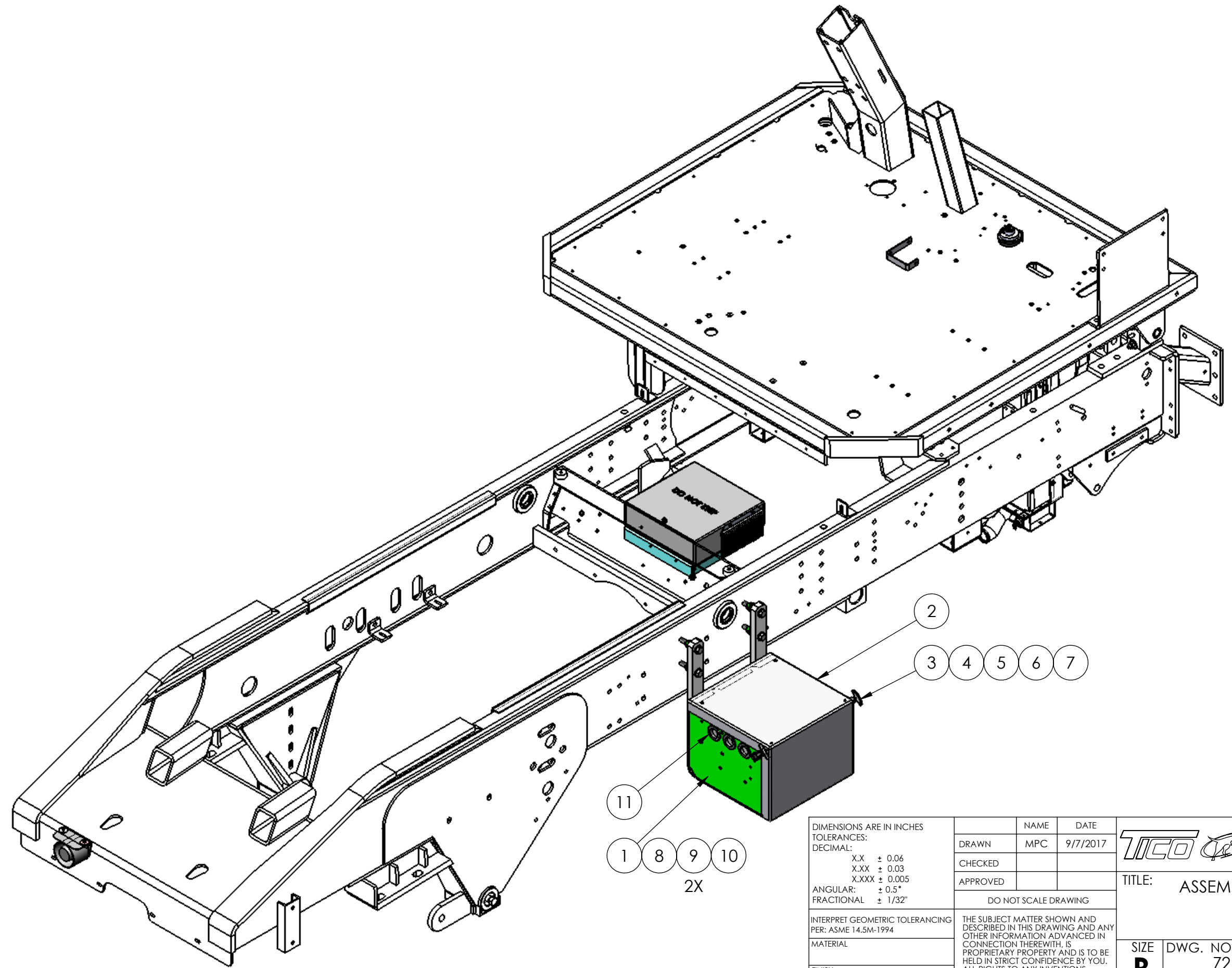

8 7 6 5 4 3 2 1

D
C
B
A



DIMENSIONS ARE IN INCHES		NAME	DATE	 TICO/TERMINAL SERVICE 66 CYPRESS RIDGE DR. RIDGELAND, SC 29936 (843) 717-2226	
TOLERANCES:		DRAWN	MPC		9/7/2017
DECIMAL:		CHECKED			
X.X ± 0.06 X.XX ± 0.03 X.XXX ± 0.005		APPROVED			
ANGULAR:		DO NOT SCALE DRAWING			
FRACTIONAL ± 1/32"		THE SUBJECT MATTER SHOWN AND DESCRIBED IN THIS DRAWING AND ANY OTHER INFORMATION ADVANCED IN CONNECTION THEREWITH, IS PROPRIETARY PROPERTY AND IS TO BE HELD IN STRICT CONFIDENCE BY YOU. ALL RIGHTS TO ANY INVENTIONS, DESIGNS, TRADE MARKS, TRADE NAMES AND COPYRIGHTS DISCLOSED ARE RESERVED TO TICO TERMINAL SERVICES, INC.			
INTERPRET GEOMETRIC TOLERANCING PER: ASME 14.5M-1994		SIZE	DWG. NO.	REV	
MATERIAL		B	721332-C1	C	
FINISH		SCALE: 1:14	WEIGHT:	SHEET 1 OF 3	
THICKNESS					

8 7 6 5 4 3 2 1

8 7 6 5 4 3 2 1

D
C
B
A

D
C
B
A

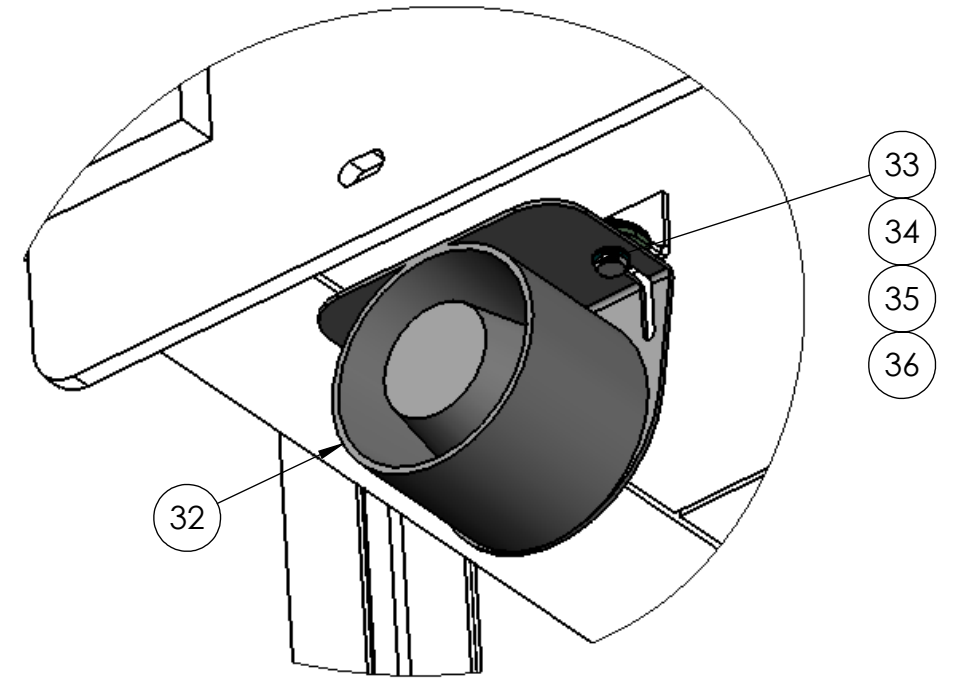
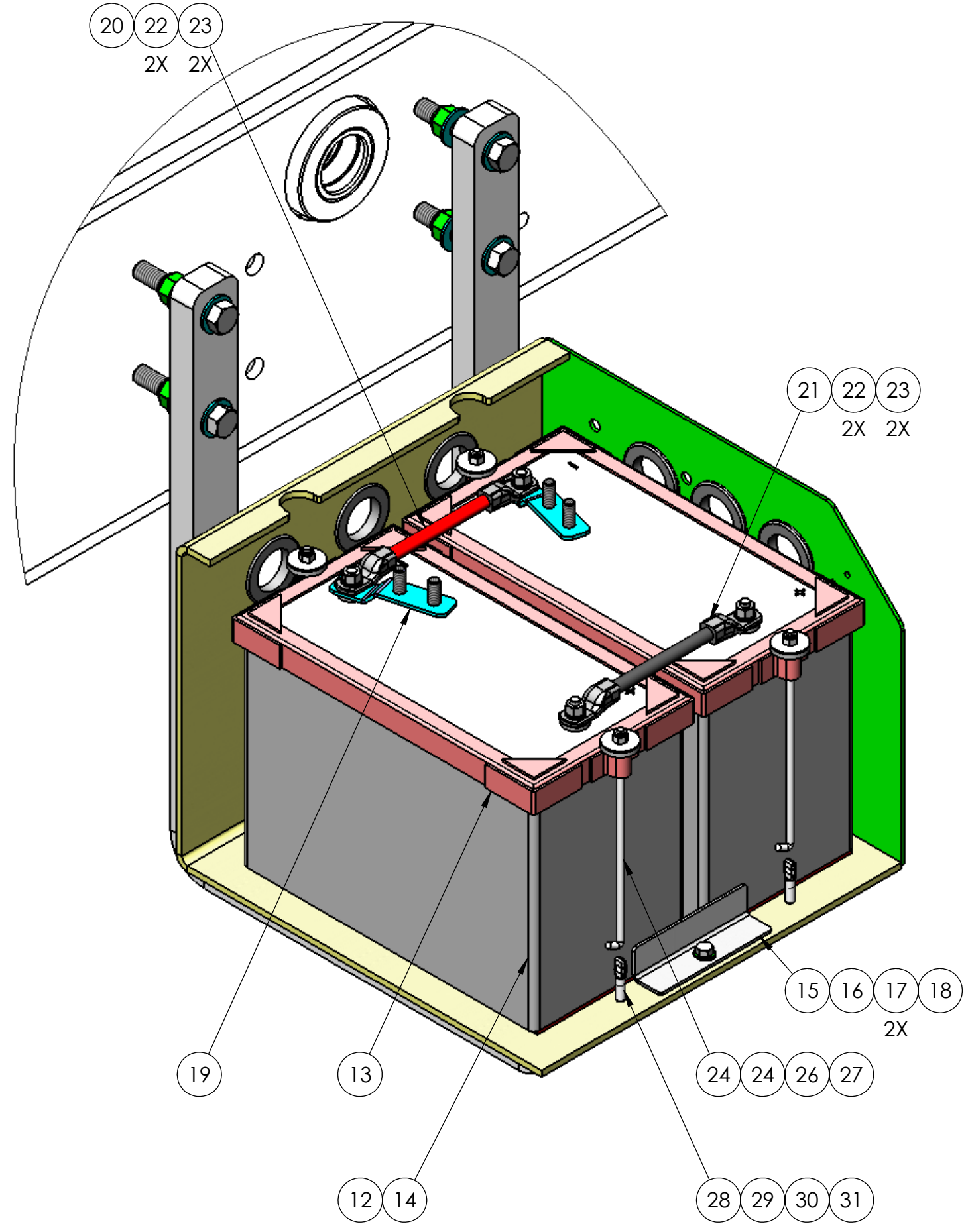

DIMENSIONS ARE IN INCHES TOLERANCES: DECIMAL: X.X ± 0.06 X.XX ± 0.03 X.XXX ± 0.005 ANGULAR: ± 0.5° FRACTIONAL ± 1/32"	NAME	DATE	 TICO/TERMINAL SERVICE 66 CYPRESS RIDGE DR. RIDGELAND, SC 29936 (843) 717-2226	
	DRAWN	MPC		9/7/2017
	CHECKED			
	APPROVED			
INTERPRET GEOMETRIC TOLERANCING PER: ASME 14.5M-1994	DO NOT SCALE DRAWING		TITLE: ASSEMBLY, BATTERY & WIRING	
MATERIAL FINISH THICKNESS	THE SUBJECT MATTER SHOWN AND DESCRIBED IN THIS DRAWING AND ANY OTHER INFORMATION ADVANCED IN CONNECTION THEREWITH, IS PROPRIETARY PROPERTY AND IS TO BE HELD IN STRICT CONFIDENCE BY YOU. ALL RIGHTS TO ANY INVENTIONS, DESIGNS, TRADE MARKS, TRADE NAMES AND COPYRIGHTS DISCLOSED ARE RESERVED TO TICO TERMINAL SERVICES, INC.		SIZE B DWG. NO. 721332-C1 REV C	
	SCALE: 1:14	WEIGHT:	SHEET 2 OF 3	

8 7 6 5 4 3 2 1

8 7 6 5 4 3 2 1

D
C
B
A

D
C
B
A

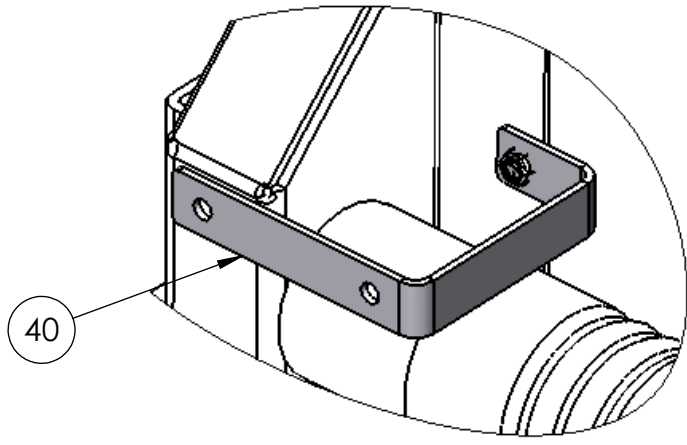
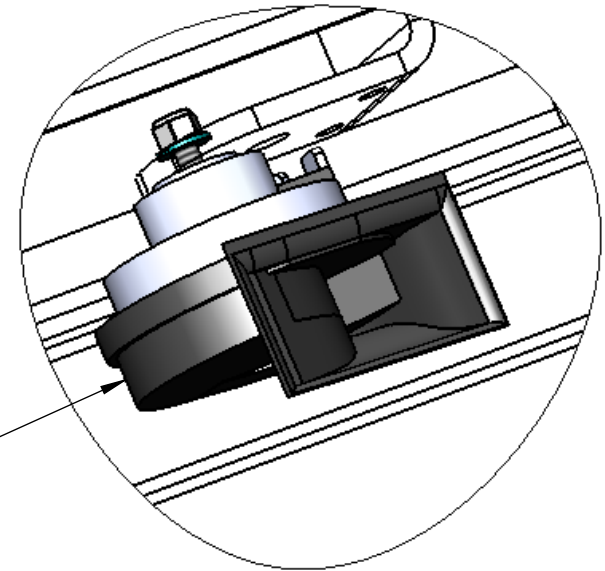

42 45 46 47
2X

41 44 46 47
2X

DIMENSIONS ARE IN INCHES TOLERANCES: DECIMAL: X.X ± 0.06 X.XX ± 0.03 X.XXX ± 0.005 ANGULAR: ± 0.5° FRACTIONAL ± 1/32"	NAME	DATE	 TICO/TERMINAL SERVICE 66 CYPRESS RIDGE DR. RIDGELAND, SC 29936 (843) 717-2226	
	DRAWN	MPC		9/7/2017
	CHECKED			
	APPROVED			
INTERPRET GEOMETRIC TOLERANCING PER: ASME 14.5M-1994	DO NOT SCALE DRAWING		TITLE: ASSEMBLY, BATTERY & WIRING	
MATERIAL	THE SUBJECT MATTER SHOWN AND DESCRIBED IN THIS DRAWING AND ANY OTHER INFORMATION ADVANCED IN CONNECTION THEREWITH, IS PROPRIETARY PROPERTY AND IS TO BE HELD IN STRICT CONFIDENCE BY YOU. ALL RIGHTS TO ANY INVENTIONS, DESIGNS, TRADE MARKS, TRADE NAMES AND COPYRIGHTS DISCLOSED ARE RESERVED TO TICO TERMINAL SERVICES, INC.		SIZE B	
FINISH			DWG. NO. 721332-C1	
THICKNESS			REV C	
	SCALE: 1:14	WEIGHT:	SHEET 3 OF 3	

8 7 6 5 4 3 2 1

