

DIMENSIONS ARE IN INCHES		NAME	DATE	TICO MANUFACTURING	
TOLERANCES:		DRAWN	ADW	06/22/2020	44 CYPRESS RIDGE DR.
DECIMAL	.005	CHECKED			ROCKLAND, NC 29154
FRACTIONAL	1/32	APPROVED			TICORACTORS.COM
ANGULAR	± 0.1°	DO NOT SCALE DRAWING			
INSURE GEOMETRIC TOLERANCING PER ASME Y14.5M					
THE SUBJECT MATTER SHOWN AND DESCRIBED IN THIS DRAWING AND ANY OTHER INFORMATION CONTAINED IN CONNECTION HEREWITH IS TO BE REPRODUCED IN WHOLE OR IN PART WITHOUT THE WRITTEN CONSENT OF TICO MANUFACTURING AND CONFORMS TO THE DRAWING AND CONSTRUCTION SPECIFICATIONS THEREON. ALL RIGHTS TO ANY PATENTS, TRADEMARKS, AND COPYRIGHTS DESCRIBED ARE RESERVED BY TICO MANUFACTURING, INC.					
TITLE: DASH COVER ASSEMBLY ISB 10		SIZE	DWG. NO.	REV	
SCALE: 1:4		D	91646-A1 ILL		
			WEIGHT: 7.29	SHEET 1 OF 1	

D 91646-A1 ILL 10/1

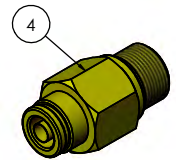

DIMENSIONS ARE IN INCHES		NAME	DATE	TICO MANUFACTURING
TOLERANCES:	DECIMAL	DRAWN	ADW	06/22/2020
	.0001 - .0004	CHECKED		44 CYPRESS RIDGE DR.
	.0005 - .0009	APPROVED		ROCKLAND, NC 27854
	.0010 - .0019			TICORACTORS.COM
	.0020 - .0029			
	.0030 - .0039			
	.0040 - .0049			
	.0050 - .0059			
	.0060 - .0069			
	.0070 - .0079			
	.0080 - .0089			
	.0090 - .0099			
	.0100 - .0109			
	.0110 - .0119			
	.0120 - .0129			
	.0130 - .0139			
	.0140 - .0149			
	.0150 - .0159			
	.0160 - .0169			
	.0170 - .0179			
	.0180 - .0189			
	.0190 - .0199			
	.0200 - .0209			
	.0210 - .0219			
	.0220 - .0229			
	.0230 - .0239			
	.0240 - .0249			
	.0250 - .0259			
	.0260 - .0269			
	.0270 - .0279			
	.0280 - .0289			
	.0290 - .0299			
	.0300 - .0309			
	.0310 - .0319			
	.0320 - .0329			
	.0330 - .0339			
	.0340 - .0349			
	.0350 - .0359			
	.0360 - .0369			
	.0370 - .0379			
	.0380 - .0389			
	.0390 - .0399			
	.0400 - .0409			
	.0410 - .0419			
	.0420 - .0429			
	.0430 - .0439			
	.0440 - .0449			
	.0450 - .0459			
	.0460 - .0469			
	.0470 - .0479			
	.0480 - .0489			
	.0490 - .0499			
	.0500 - .0509			
	.0510 - .0519			
	.0520 - .0529			
	.0530 - .0539			
	.0540 - .0549			
	.0550 - .0559			
	.0560 - .0569			
	.0570 - .0579			
	.0580 - .0589			
	.0590 - .0599			
	.0600 - .0609			
	.0610 - .0619			
	.0620 - .0629			
	.0630 - .0639			
	.0640 - .0649			
	.0650 - .0659			
	.0660 - .0669			
	.0670 - .0679			
	.0680 - .0689			
	.0690 - .0699			
	.0700 - .0709			
	.0710 - .0719			
	.0720 - .0729			
	.0730 - .0739			
	.0740 - .0749			
	.0750 - .0759			
	.0760 - .0769			
	.0770 - .0779			
	.0780 - .0789			
	.0790 - .0799			
	.0800 - .0809			
	.0810 - .0819			
	.0820 - .0829			
	.0830 - .0839			
	.0840 - .0849			
	.0850 - .0859			
	.0860 - .0869			
	.0870 - .0879			
	.0880 - .0889			
	.0890 - .0899			
	.0900 - .0909			
	.0910 - .0919			
	.0920 - .0929			
	.0930 - .0939			
	.0940 - .0949			
	.0950 - .0959			
	.0960 - .0969			
	.0970 - .0979			
	.0980 - .0989			
	.0990 - .0999			
	1.0000 - 1.0009			
	1.0010 - 1.0019			
	1.0020 - 1.0029			
	1.0030 - 1.0039			
	1.0040 - 1.0049			
	1.0050 - 1.0059			
	1.0060 - 1.0069			
	1.0070 - 1.0079			
	1.0080 - 1.0089			
	1.0090 - 1.0099			
	1.0100 - 1.0109			
	1.0110 - 1.0119			
	1.0120 - 1.0129			
	1.0130 - 1.0139			
	1.0140 - 1.0149			
	1.0150 - 1.0159			
	1.0160 - 1.0169			
	1.0170 - 1.0179			
	1.0180 - 1.0189			
	1.0190 - 1.0199			
	1.0200 - 1.0209			
	1.0210 - 1.0219			
	1.0220 - 1.0229			
	1.0230 - 1.0239			
	1.0240 - 1.0249			
	1.0250 - 1.0259			
	1.0260 - 1.0269			
	1.0270 - 1.0279			
	1.0280 - 1.0289			
	1.0290 - 1.0299			
	1.0300 - 1.0309			
	1.0310 - 1.0319			
	1.0320 - 1.0329			
	1.0330 - 1.0339			
	1.0340 - 1.0349			
	1.0350 - 1.0359			
	1.0360 - 1.0369			
	1.0370 - 1.0379			
	1.0380 - 1.0389			
	1.0390 - 1.0399			
	1.0400 - 1.0409			
	1.0410 - 1.0419			
	1.0420 - 1.0429			
	1.0430 - 1.0439			
	1.0440 - 1.0449			
	1.0450 - 1.0459			
	1.0460 - 1.0469			
	1.0470 - 1.0479			
	1.0480 - 1.0489			
	1.0490 - 1.0499			
	1.0500 - 1.0509			
	1.0510 - 1.0519			
	1.0520 - 1.0529			
	1.0530 - 1.0539			
	1.0540 - 1.0549			
	1.0550 - 1.0559			
	1.0560 - 1.0569			
	1.0570 - 1.0579			
	1.0580 - 1.0589			
	1.0590 - 1.0599			
	1.0600 - 1.0609			
	1.0610 - 1.0619			
	1.0620 - 1.0629			
	1.0630 - 1.0639			
	1.0640 - 1.0649			
	1.0650 - 1.0659			
	1.0660 - 1.0669			
	1.0670 - 1.0679			
	1.0680 - 1.0689			
	1.0690 - 1.0699			
	1.0700 - 1.0709			
	1.0710 - 1.0719			
	1.0720 - 1.0729			
	1.0730 - 1.0739			
	1.0740 - 1.0749			
	1.0750 - 1.0759			
	1.0760 - 1.0769			
	1.0770 - 1.0779			
	1.0780 - 1.0789			
	1.0790 - 1.0799			
	1.0800 - 1.0809			
	1.0810 - 1.0819			
	1.0820 - 1.0829			
	1.0830 - 1.0839			
	1.0840 - 1.0849			
	1.0850 - 1.0859			
	1.0860 - 1.0869			
	1.0870 - 1.0879			
	1.0880 - 1.0889			
	1.0890 - 1.0899			
	1.0900 - 1.0909			
	1.0910 - 1.0919			
	1.0920 - 1.0929			
	1.0930 - 1.0939			
	1.0940 - 1.0949			
	1.0950 - 1.0959			
	1.0960 - 1.0969			
	1.0970 - 1.0979			
	1.0980 - 1.0989			
	1.0990 - 1.0999			
	1.1000 - 1.1009			
	1.1010 - 1.1019			
	1.1020 - 1.1029			
	1.1030 - 1.1039			
	1.1040 - 1.1049			
	1.1050 - 1.1059			
	1.1060 - 1.1069			
	1.1070 - 1.1079			
	1.1080 - 1.1089			
	1.1090 - 1.1099			
	1.1100 - 1.1109			
	1.1110 - 1.1119			
	1.1120 - 1.1129			
	1.1130 - 1.1139			
	1.1140 - 1.1149			
	1.1150 - 1.1159			
	1.1160 - 1.1169			
	1.1170 - 1.1179			
	1.1180 - 1.1189			
	1.1190 - 1.1199			
	1.1200 - 1.1209			
	1.1210 - 1.1219			
	1.1220 - 1.1229			
	1.1230 - 1.1239			
	1.1240 - 1.1249			
	1.1250 - 1.1259			
	1.1260 - 1.1269			
	1.1270 - 1.1279			
	1.1280 - 1.1289			
	1.1290 - 1.1299			
	1.1300 - 1.1309			
	1.1310 - 1.1319			
	1.1320 - 1.1329			
	1.1330 - 1.1339			
	1.1340 - 1.1349			
	1.1350 - 1.1359			
	1.1360 - 1.1369			
	1.1370 - 1.1379			
	1.1380 - 1.1389			
	1.1390 - 1.1399			
	1.1400 - 1.1409			
	1.1410 - 1.1419			
	1.1420 - 1.1429			
	1.1430 - 1.1439			
	1.1440 - 1.1449			
	1.1450 - 1.1459			
	1.1460 - 1.1469			
	1.1470 - 1.1479			
	1.1480 - 1.1489			
	1.1490 - 1.1499			
	1.1500 - 1.1509			
	1.1510 - 1.1519			
	1.1520 - 1.1529			
	1.1530 - 1.1539			
	1.1540 - 1.1549			
	1.1550 - 1.1559			
	1.1560 - 1.1569			
	1.1570 - 1.1579			
	1.1580 - 1.1589			
	1.1590 - 1.1599			
	1.1600 - 1.1609			
	1.1610 - 1.1619			
	1.1620			

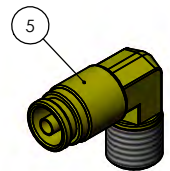
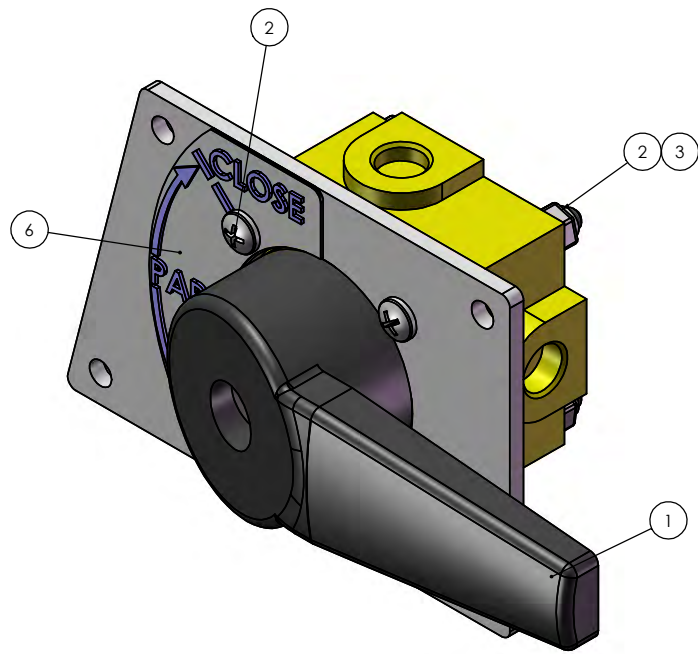
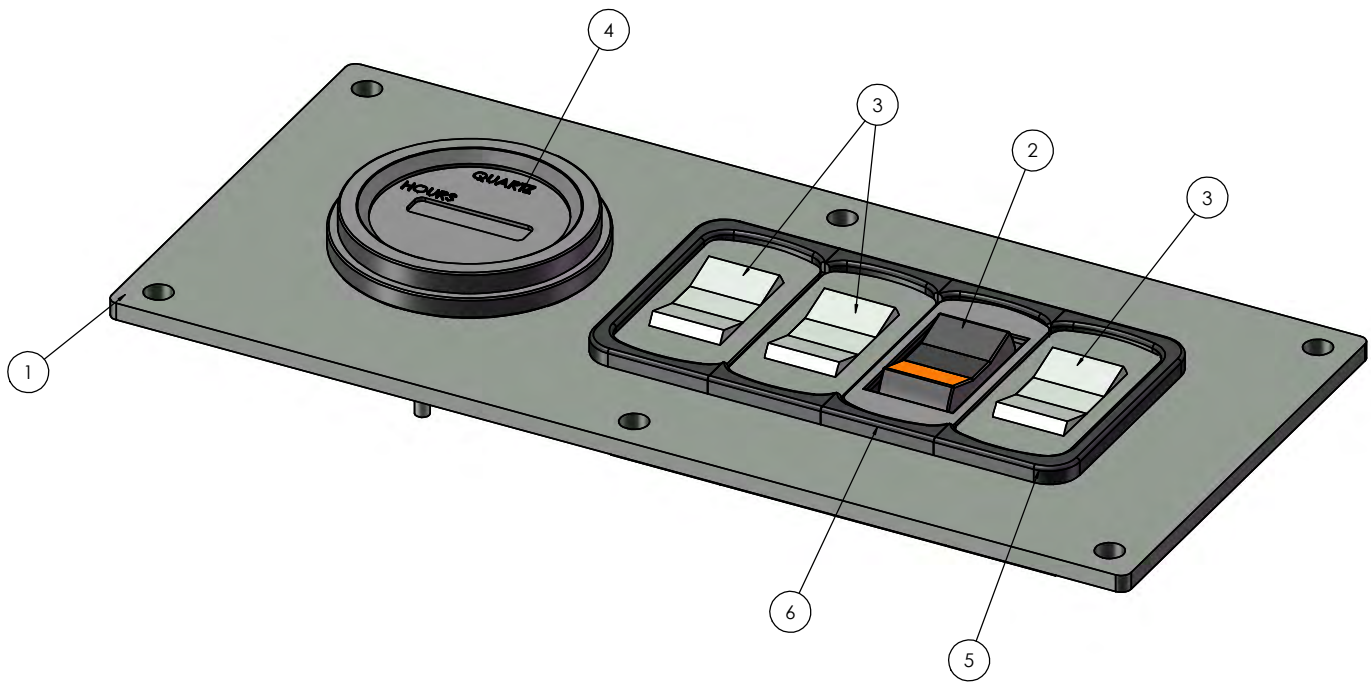

DIMENSIONS ARE IN INCHES		NAME	DATE	TICO MANUFACTURING 66 CYPRESS RIDGE DR. SOCIETY, SC 29584 TICORACTORS.COM
TOLERANCES:	DECIMAL	DRAWN	AGW	
	XX	± 0.04		
	XXX	± 0.02		
	ANGULAR	± 0.1°		
	FRACTIONAL	± 1/32"		
UNLESS OTHERWISE SPECIFIED		ISOMET SCALE DRAWING		
UNLESS OTHERWISE SPECIFIED		THE SUBJECT MATTER SHOWN AND DESCRIBED IN THE DRAWING AND ANY OTHER INFORMATION ADVANCED IN CONNECTION HEREBY IS TO BE ALL RIGHTS TO ANY PATENT, TRADE MARK, OR COPYRIGHT RESERVED AND ARE RESERVED TO TICO MANUFACTURING, INC.		
TITLED		ASSY. PANEL HOURMETER/DIAGNOSTIC		
SIZE		DWG. NO.		REV
D		910470-A1		
SCALE: 1:1		WEIGHT:		SHEET 1 OF 1

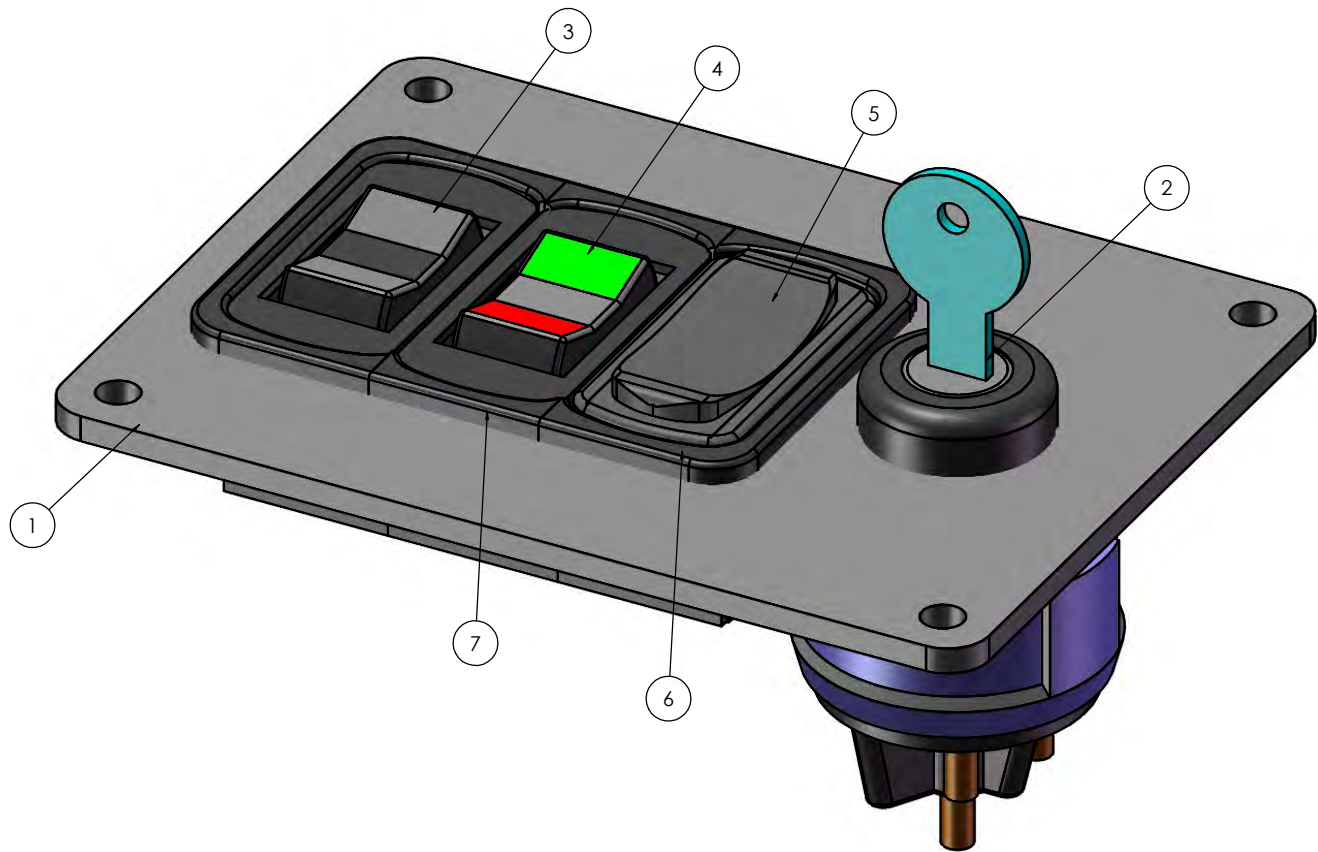

DIMENSIONS ARE IN INCHES		NAME	DATE	 TICO MANUFACTURING 44 C. PRESS RIDGE DR. ROSELAND, SC 29376 TICO@TICO.COM
TOLERANCES:	DECIMAL	DRAWN	AGW	
	.XX & .04	CHECKED		
	.XX & .05	APPROVED		
	.XX & .005			
ANGULAR	± .1°	DO NOT SCALE DRAWING		
FRACTONAL	± .002	RE: SEE LIST ATTACHED WITH THIS DRAWING AND ANY CHANGES MADE TO THIS DRAWING IN CONNECTION WITH THIS PROJECT. REVISIONS & PRECEDENT PROPERTY ARE TO BE HELD IN STRICT CONFIDENCE FOR ALL PARTS. ALL DIMENSIONS GIVEN IN THIS DRAWING ARE SUBJECT TO REVISIONS. CONTACT TICO FOR ANY CHANGES TO THIS DRAWING.		
PERFORM DIMENSIONING TO FOLLOWING PER ASME Y14.5M 1994		RE: SEE LIST ATTACHED WITH THIS DRAWING AND ANY CHANGES MADE TO THIS DRAWING IN CONNECTION WITH THIS PROJECT. REVISIONS & PRECEDENT PROPERTY ARE TO BE HELD IN STRICT CONFIDENCE FOR ALL PARTS. ALL DIMENSIONS GIVEN IN THIS DRAWING ARE SUBJECT TO REVISIONS. CONTACT TICO FOR ANY CHANGES TO THIS DRAWING.		
UNIT:	N/A	SIZE DWG. NO. 91D466-A1		
TITLE:		ASSEMBLY PANEL DASH KEYLESS IGNITION SWITCH		
TOLERANCE:		SCALE: 1:1		
		WEIGHT: SHEET 1 OF 1		

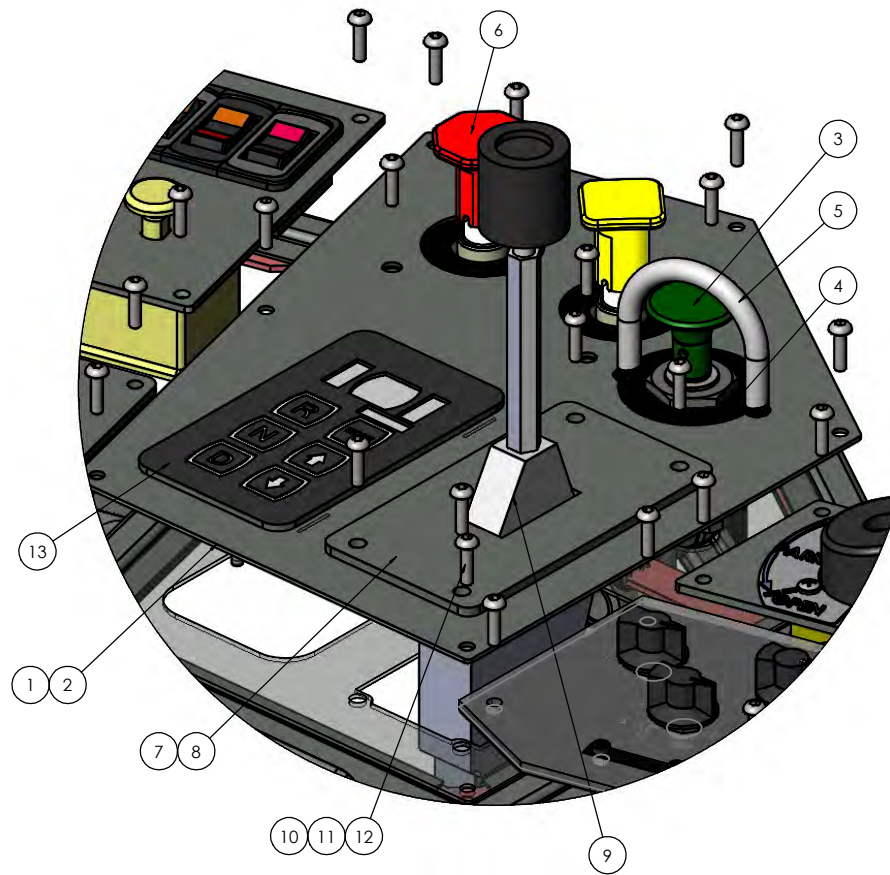

DIMENSIONS ARE IN INCHES		NAME	DATE	TICO MANUFACTURING	
TOLERANCES:		DRAWN	ACW	06/10/2020	AS CYPRUS ROAD DR.
DECIMAL	± .04	CHECKED			TICOMANUFACTURING.COM
FRACTIONAL	± .005	APPROVED			
ANGULAR	± .1°	DO NOT SCALE DRAWING			
FRACTIONAL	± .1°	IF YOU HAVE ANY COMMENTS OR			
PLEASE CONTACT THE DRAWING		CONTRACTOR, CONTACT THE			
FOR NAME IN 2019		DESIGNER/ENGINEER AND			
		PROJECT/PROPERTY AND TO BE			
		REVISOR/ENGINEER FOR			
		ALL DIMENSIONS ARE IN INCHES			
		UNLESS OTHERWISE SPECIFIED			
		HAND AND COPY RIGHTS RESERVED			
		ARE RESERVED TO TICO MANUFACTURING			
		TITLE		DASH PANEL-PB	
		SIZE		DWG. NO. 200344-A1	
		SCALE: 1:4		WEIGHT: 23.22	
		SHEET 1 OF 1		REV	



DIMENSIONS ARE IN INCHES		NAME	DATE	TICO MANUFACTURING
TOLERANCES:		DRAWN	ADW	04/22/2020
DECIMAL	.005	CHECKED		44 CYPRESS RIDGE DR.
FRACTIONAL	1/32	APPROVED		ROCKLAND, NC 27854
ANGULAR	± 0.1°			TICORACTORS.COM
FUNCTIONAL	± 0.005			
DO NOT SCALE DRAWING		TITLE: HEATER CONTROL ASSEMBLY		
INSURE GEOMETRIC TOLERANCING PER ASME Y14.5M		THE SUBJECT MATTER SHOWN AND DESCRIBED IN THIS DRAWING AND ANY OTHER INFORMATION CONTAINED IN CONNECTION HEREWITH IS TO BE USED FOR THE PURPOSES OF THIS DRAWING ONLY. ALL RIGHTS TO ANY PATENTS, TRADEMARKS, AND COPYRIGHTS RESERVED AND ARE RESERVED BY TICO MANUFACTURING, INC.		
DATE:	04/22/2020	SIZE	DWG. NO.	REV
REVISIONS:		D	20900-A1 ILL	
		SCALE: 1:1	WEIGHT: 0.27	SHEET 1 OF 1

D 20900-A1 ILL 001

