

DIMENSIONS ARE IN INCHES TOLERANCES: DECIMALS .005 FRACTIONS 1/32 ANGULAR 1/4° MIN HOLE POSITION .005 HOLE DIA .005 HOLE DIA .005 HOLE DIA .005	NAME DATE DRAWN AGW 04/03/2020 CHECKED APPROVED DESIGNSOURCE DRAWINGS	TICO MANUFACTURING 44 STEVENS ROAD DR BURLINGTON, NC 29936 (843) 717-2222
THE SUBJECT MATTER SHOWN AND DESCRIBED HEREIN IS THE PROPERTY OF TICO MANUFACTURING AND IS TO BE KEPT CONFIDENTIAL. IT IS TO BE KEPT CONFIDENTIAL AND NOT TO BE REPRODUCED OR TRANSMITTED IN ANY FORM OR BY ANY MEANS, ELECTRONIC OR MECHANICAL, INCLUDING PHOTOCOPYING, RECORDING, OR BY ANY INFORMATION STORAGE AND RETRIEVAL SYSTEM, WITHOUT THE WRITTEN PERMISSION OF TICO MANUFACTURING.	TITLE: DASH ASSY-QSB-RDS, KPH - 12V-PUSH BUTTN- KEY	SRE DWG. NO. D 72058-C1 REV
SEE NOTE TOLERANCES: DIMENSIONS ARE IN INCHES TOLERANCES: DECIMALS .005 FRACTIONS 1/32 ANGULAR 1/4° MIN HOLE POSITION .005 HOLE DIA .005 HOLE DIA .005 HOLE DIA .005	SCALE: 1:1 WEIGHT: 19.49 SHEET 1 OF 1	

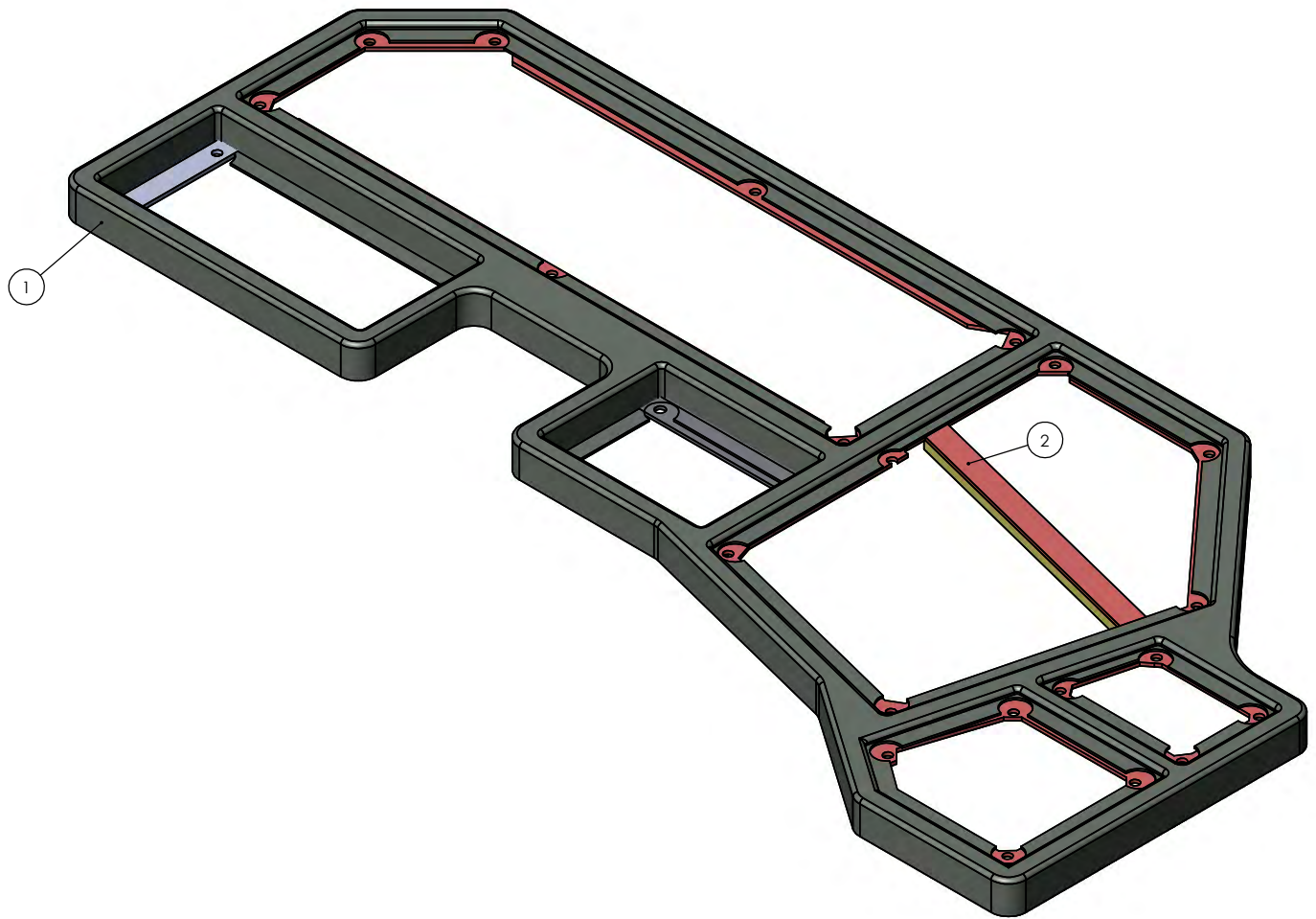

DIMENSIONS ARE IN INCHES		NAME	DATE	TICO MANUFACTURING	
TOLERANCES:		DRAWN	ADW	06/22/2020	66 CYPRESS RIDGE DR.
DECIMAL	.0005	CHECKED			ROCKLAND, NC 29154
FRACTIONAL	1/32	APPROVED			TICORACTORS.COM
ANGULAR	± 0.1°	DO NOT SCALE DRAWING			
INSURE GEOMETRIC TOLERANCING PER ASME Y14.5M					
THE SUBJECT MATTER SHOWN AND DESCRIBED IN THIS DRAWING AND ANY OTHER INFORMATION CONTAINED IN CONNECTION HEREWITH IS TO BE REPRODUCED IN WHOLE OR IN PART WITHOUT THE WRITTEN CONSENT OF TICO MANUFACTURING AND CONFORMS TO THE DRAWING AND CONSTRUCTION SPECIFICATIONS AND ALL RIGHTS TO ANY PATENTS, TRADE MARKS AND COPYRIGHTS HEREOF ARE RESERVED BY TICO MANUFACTURING, INC.					
TITLE: DASH COVER ASSEMBLY ISB 10		SIZE	DWG. NO.	REV	
		D	91646-A1 ILL		
SCALE: 1:4		WEIGHT: 7.29	SHEET 1 OF 1		

D 91646-A1 ILL 10/1

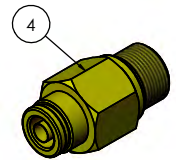
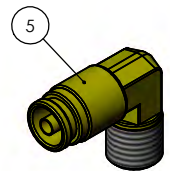
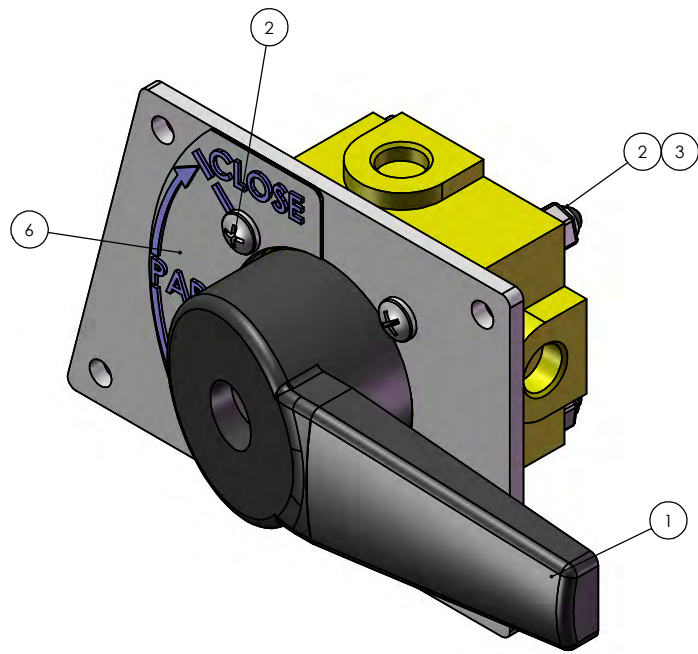

DIMENSIONS ARE IN INCHES		NAME	DATE	TICO MANUFACTURING
TOLERANCES:	DECIMAL	DRAWN	ADW	06/22/2020
	.005	CHECKED		44 CYPRESS RIDGE DR.
	.010	APPROVED		ROCKLAND, NC 27854
	.015			TICORACTORS.COM
	.030			
ANGULAR:	± 1.0°	DO NOT SCALE DRAWING		
FRACTIONAL:	± .005	THE SUBJECT MATTER SHOWN AND		
		DESCRIBED IN THIS DRAWING AND ANY		
		OTHER REFERENCE IS UNLESS IN		
		CONNECTION OTHERWISE TO BE		
		MADE FROM CONFORMING BRASS		
		ALL RIGHTS TO ANY PATENTS OR		
		OTHER INTELLECTUAL PROPERTY		
		HEREIN ARE RESERVED AND WILL		
		BE REMAINED BY TICO MANUFACTURING		
		OR ITS AFFILIATES.		
		SCALE: 1:1		
		WEIGHT:		
		SHEET 1 OF 1		

TICO
 TITLE: ASSEMBLY, PANEL DASH
 DOOR VALVE

SIZE DWG. NO. REV
D 20183-A1 ILL
 SCALE: 1:1 WEIGHT: SHEET 1 OF 1

D 20183-A1 ILL

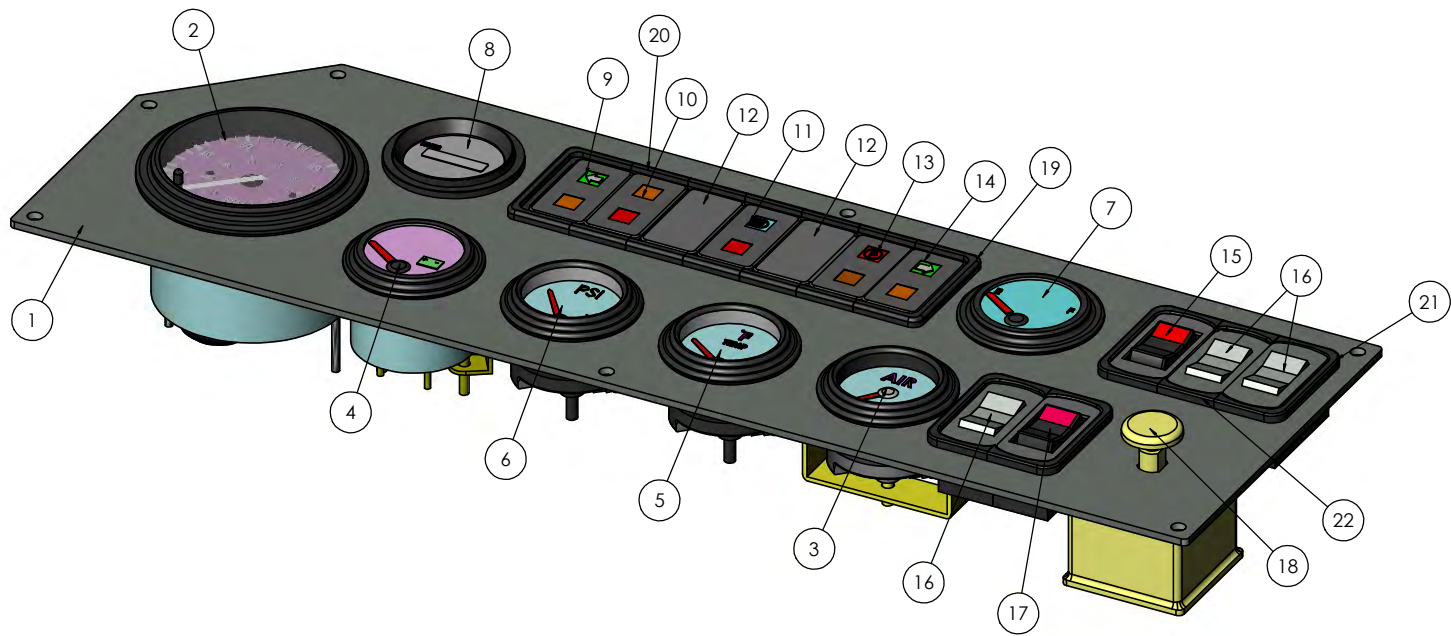

DIMENSIONS ARE IN INCHES TOLERANCES: DECIMAL: ± 0.04 FRACTIONAL: ± 0.03 HOLE: ± 0.02 HOLE: ± 0.02 HOLE: ± 0.02		NAME: JACW DATE: 06/10/2020	<p>TICO MANUFACTURING 64 CHERRY RIDGE DR. BOGGSVILLE, SC 29036 TICOFACTORS.COM</p>
<p>APPROVED: _____</p> <p>DO NOT SCALE DRAWING</p> <p>THIS SUBJECT MATTER IS UNLESS AND OTHERWISE SPECIFIED BY THE DRAWING AND ANY OTHER DOCUMENTS AND ANY OTHER DOCUMENTS ARE SUBJECT TO THE TERMS AND CONDITIONS OF THE TICO MANUFACTURING PURCHASE ORDER.</p>		<p>TITLE: PANEL ASSY DASH GAUGE CLUSTER</p> <p>SIZE: DWG. NO. 910491-A1</p> <p>SCALE: 1:2 WEIGHT: 5.77 SHEET 1 OF 1</p>	

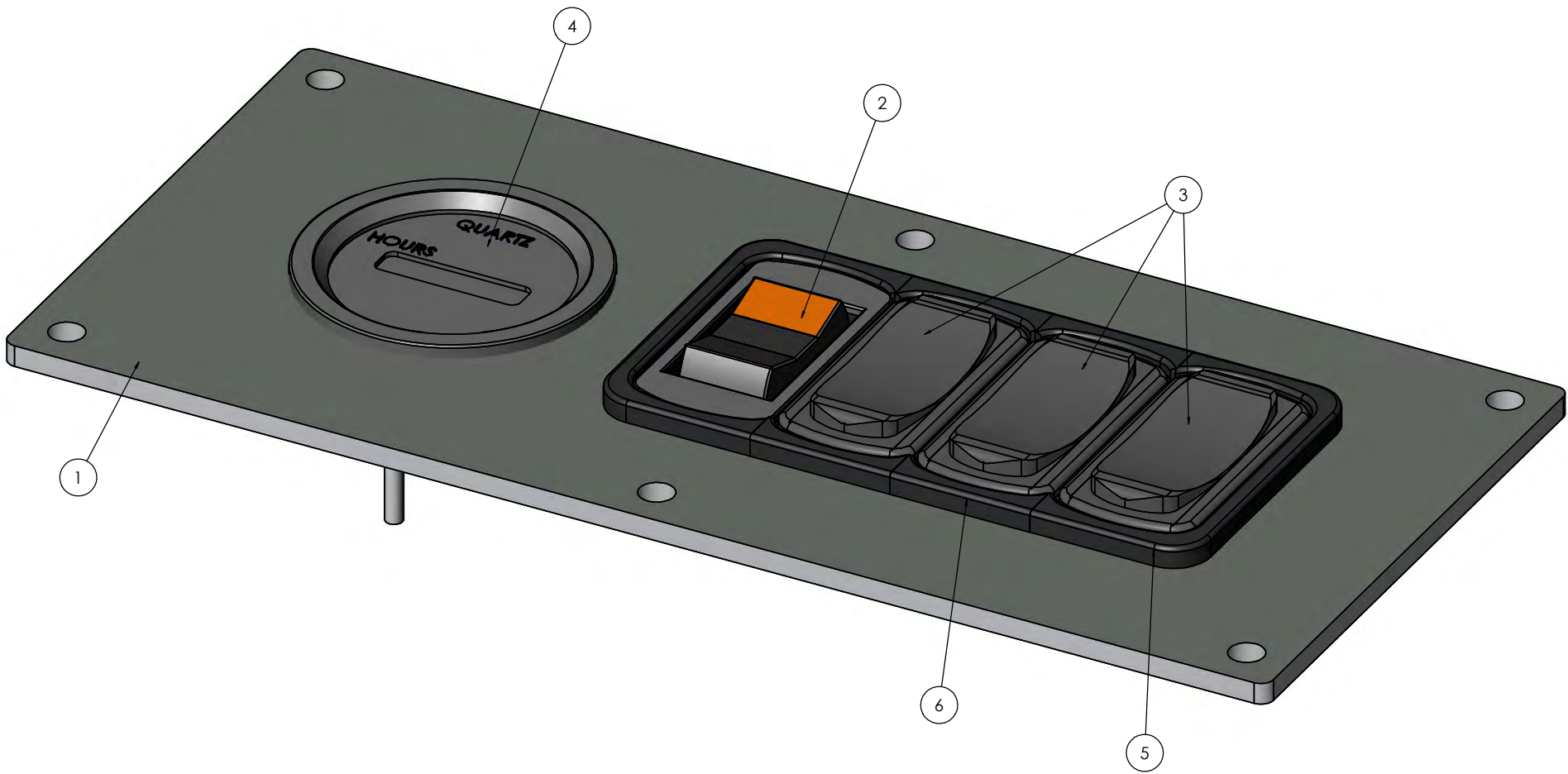

DIMENSIONS ARE IN INCHES		NAME	DATE	 TICO MANUFACTURING 64 CYPRESS BRIDGE DR. BUCKLEHEAD, SC 29136 TICOFACTORY.COM	
TECHNICAL	XXX	AGW	06/10/2020		
SECTION	XXX	AGW	06/10/2020		
APPROVED	XXX	AGW	06/10/2020		
DATE	06/10/2020	APPROVED	06/10/2020	TITLE	
DO NOT SCALE DRAWING THIS DRAWING IS THE PROPERTY OF TICO MANUFACTURING AND IS TO BE USED ONLY FOR THE PURPOSES SPECIFIED IN THE DRAWING. ANY REPRODUCTION OR TRANSMISSION OF THIS DRAWING WITHOUT THE WRITTEN PERMISSION OF TICO MANUFACTURING IS STRICTLY PROHIBITED.				ASSY PANEL HOURMETER/DIAGNOSTIC - ISB	
SCALE	1:1	WEIGHT	0.42	SHEET	1 OF 1

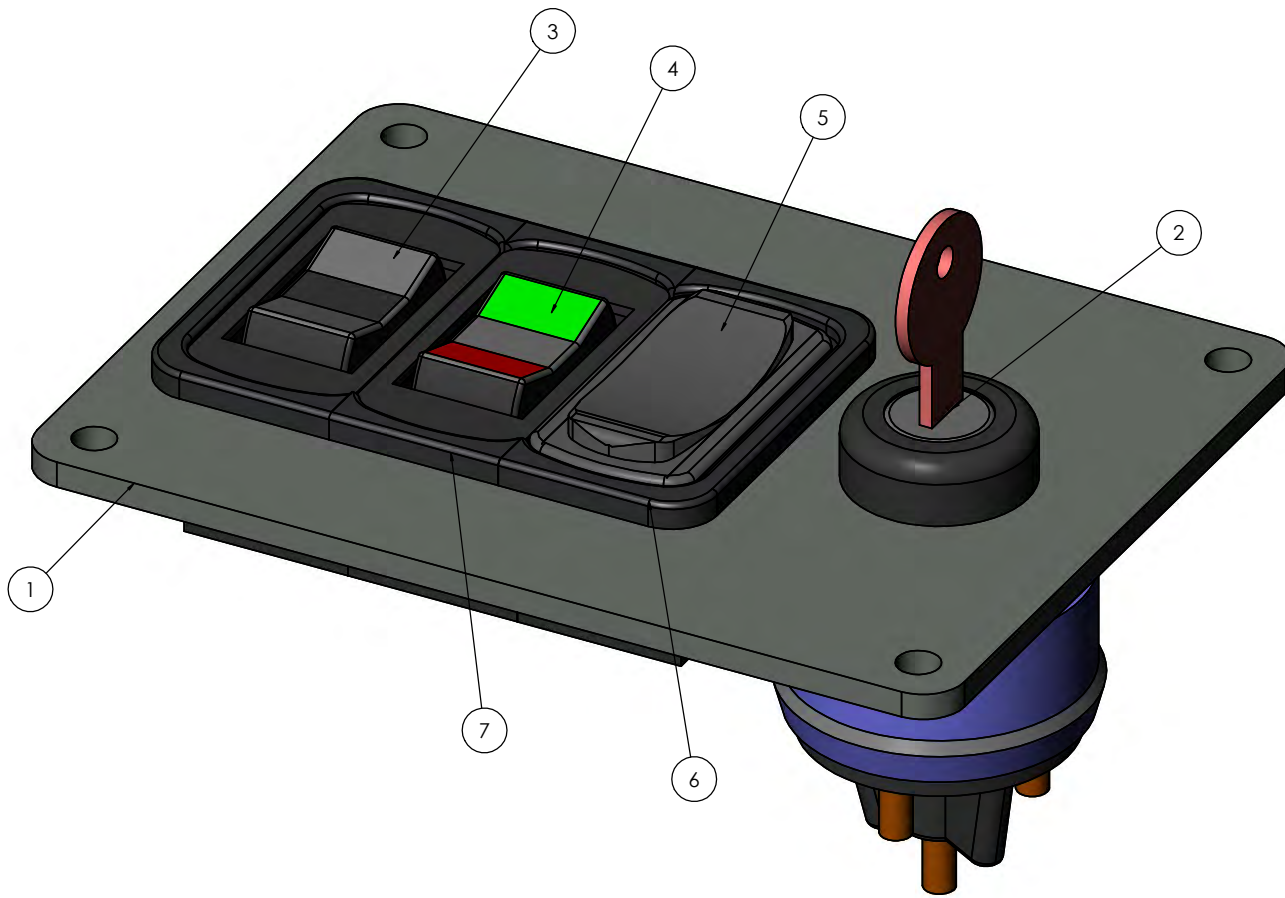

DIMENSIONS ARE IN INCHES		NAME	DATE	TICO MANUFACTURING
TOLERANCES:		DRAWN	ADW	04/10/2020
DECIMAL	.0005	CHECKED		AA CYPRESS RIDGE DR.
ANGLE	.001	APPROVED		ROCKLAND, SC 29574
FRACTIONAL	1/16			TICORACTORS.COM
ANGULAR	± 1.0°	DO NOT SCALE DRAWING		
FUNCTIONAL	± 1.0°	THE SUBJECT MATTER SHOWN AND DESCRIBED IN THIS DRAWING AND ANY OTHER INFORMATION CONTAINED HEREIN IS THE PROPERTY OF TICO MANUFACTURING AND IS TO BE KEPT IN CONFIDENCE BY ALL PERSONS TO WHOM IT IS SOLELY OR PARTIALLY DISCLOSED AND IS NOT TO BE REPRODUCED OR TRANSMITTED IN ANY FORM OR BY ANY MEANS, ELECTRONIC OR MECHANICAL, INCLUDING PHOTOCOPYING, RECORDING, OR BY ANY INFORMATION STORAGE AND RETRIEVAL SYSTEM.		
INSURER OR CONTRACT COVERS WORKING FOR NAME IS LAWYER		N/A		
DATE		N/A		
DESIGN		N/A		
SEE NOTE		N/A		
REVISION		N/A		

TICO
 TITLE: ASSEMBLY PANEL-DASH KEY IGNITION SWITCH
 SIZE: D DWG. NO. 910466-A1 REV
 SCALE: 1:1 | WEIGHT: 0.36 | SHEET 1 OF 1

910466-A1

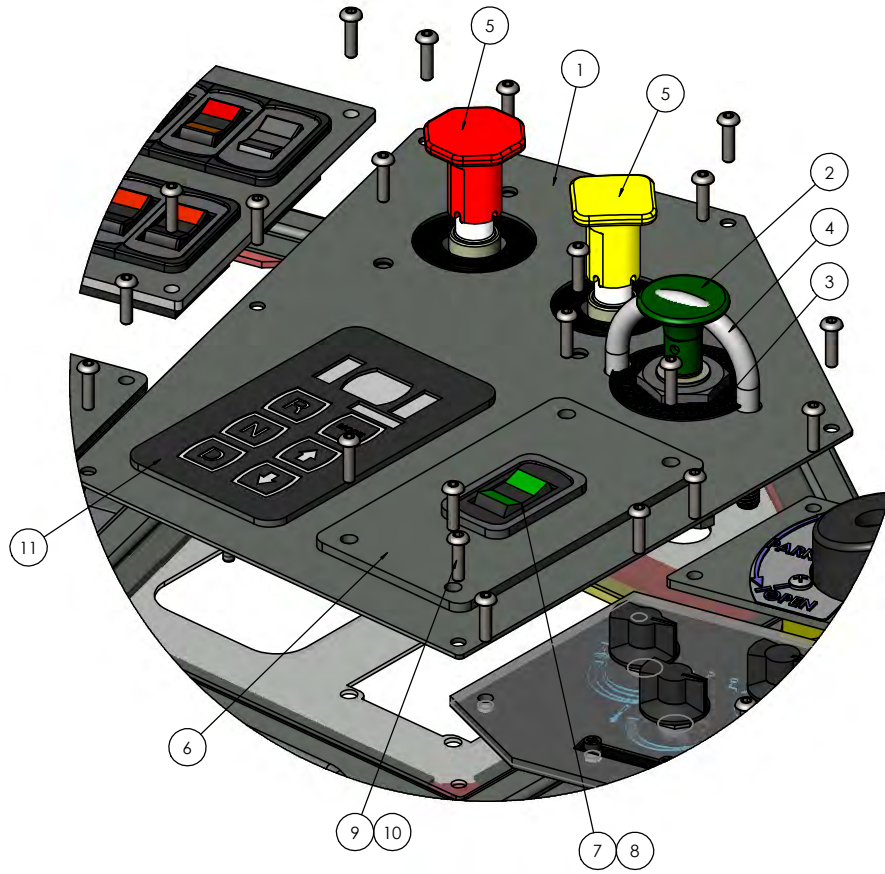

DIMENSIONS ARE IN INCHES TOLERANCES: DECIMAL: .1 & .04 FRACTIONAL: 1/16, 1/8, 3/16, 1/4, 3/8, 1/2, 5/8, 3/4, 7/8, 1		NAME: AGW DATE: 06/02/2008	TICO MANUFACTURING 16 CYPRESS RIDGE DR. REDLANDS, SC 29076 TICO@TICO.COM
APPROVED:	DO NOT SCALE DRAWING	RE SUBJECT MATTER DRAWING AND DESIGNED IN THE COMPANY AND ANY COPYING OR REPRODUCTION IN WHOLE OR IN PART IS STRICTLY PROHIBITED. VIOLATION IS PUNISHABLE BY LAW. TRADE MARKS AND SERVICE MARKS ARE THE PROPERTY OF THEIR RESPECTIVE OWNERS.	TITLE: DASH PANEL-PB SHIFTER/HEATER/MV3/ELEC
REVISIONS: REV: 1 DATE: 06/02/2008 BY: AGW	REVISIONS: REV: 1 DATE: 06/02/2008 BY: AGW	SIZE: DWG. NO. 20116-A1 ILL SCALE: 1:4 WEIGHT: 18.03 SHEET 1 OF 1	REV: 1



DIMENSIONS ARE IN INCHES		NAME	DATE	TICO MANUFACTURING
TOLERANCES:		DRAWN	ADW	04/22/2020
DECIMAL	.005	CHECKED		44 CYPRESS RIDGE DR. ROCKLAND, NC 27854 TICORACTORS.COM
FRACTIONAL	1/32	APPROVED		
ANGULAR	± 0.1°	DO NOT SCALE DRAWING		
FUNCTIONAL	± 0.005	THE SUBJECT MATTER SHOWN AND DESCRIBED IN THIS DRAWING AND ANY OTHER INFORMATION CONTAINED HEREIN IS THE PROPERTY OF TICO MANUFACTURING AND IS TO BE KEPT IN CONFIDENTIALITY. ALL RIGHTS TO ANY PATENTS, TRADEMARKS, AND/OR OTHER INTELLECTUAL PROPERTY ARE RESERVED BY TICO MANUFACTURING.		
WATERPROOFING		TICO MANUFACTURING		
REVISIONS		SCALE: 1:1 WEIGHT: 0.27 SHEET 1 OF 1		

D 20900-A1 ILL

TICO
TITLE: HEATER CONTROL ASSEMBLY

SIZE DWG. NO. 20900-A1 ILL REV
D

