

DETAIL A
SCALE 1 : 4

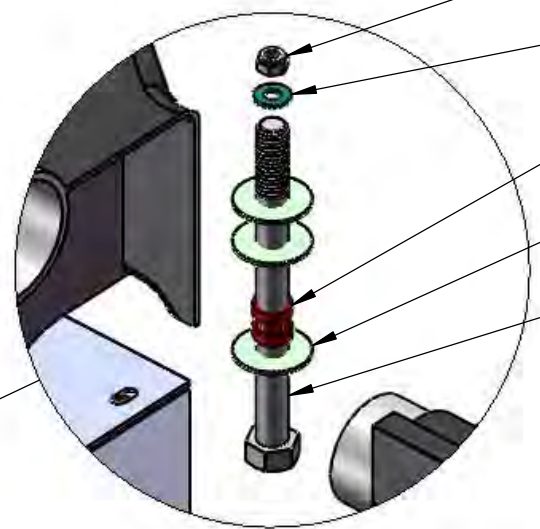

DETAIL B
SCALE 1 : 3

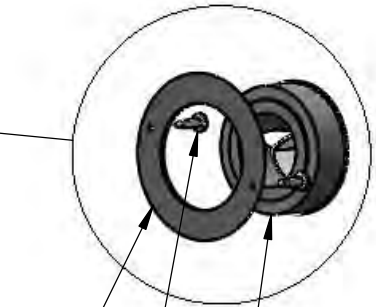

DETAIL C
SCALE 1 : 4

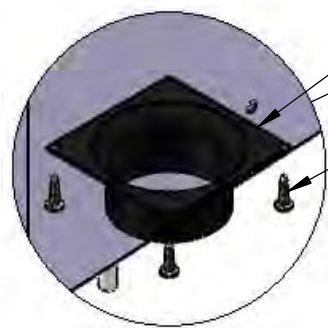

DETAIL E
SCALE 1 : 4

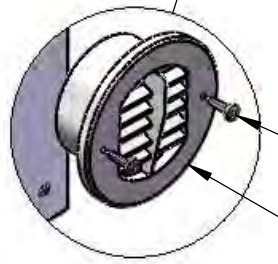

DETAIL D
SCALE 1 : 4

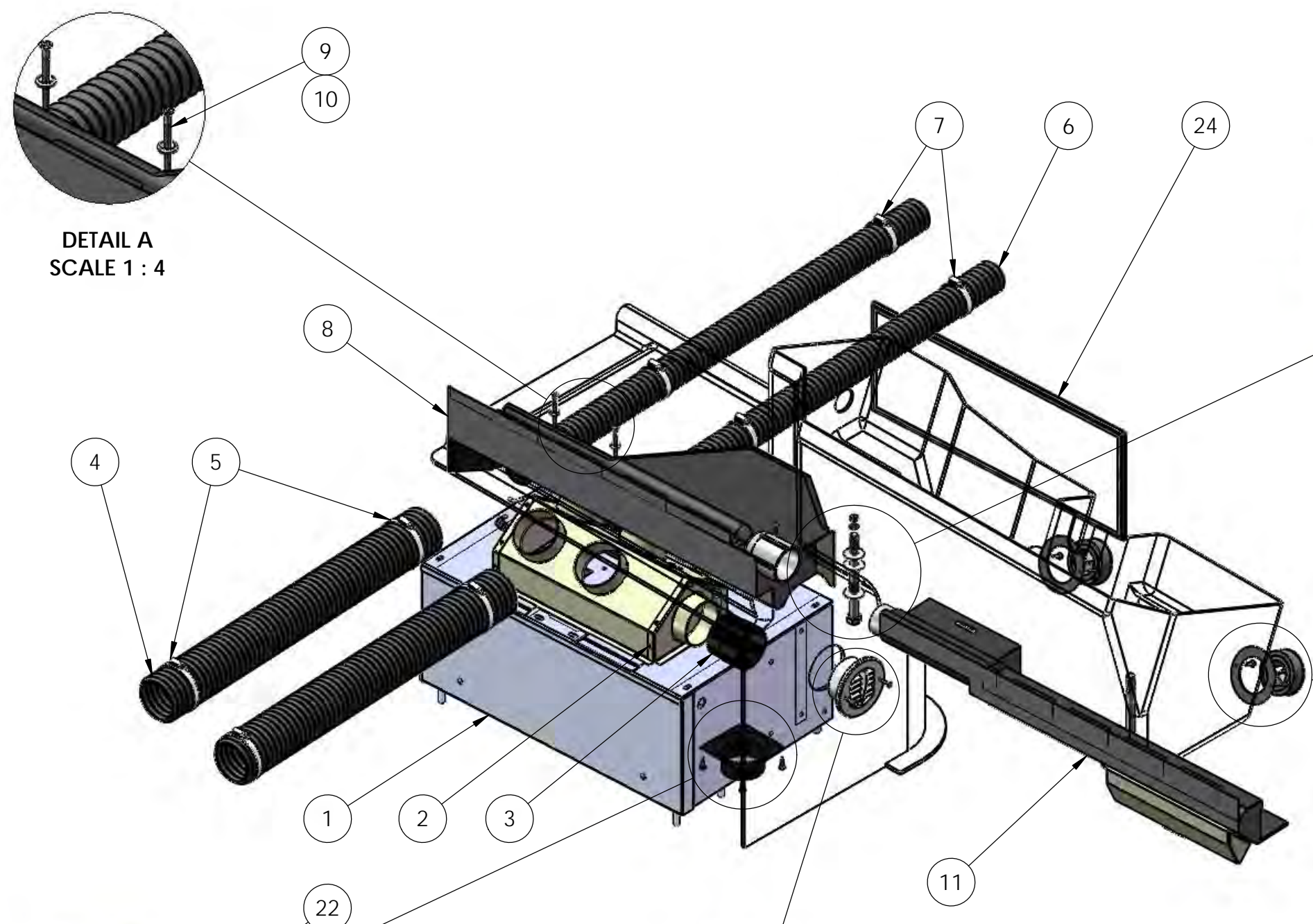

| | | | |
|--|---|--------------|--|
| DIMENSIONS ARE IN INCHES TOLERANCES: DECIMAL: X.X ± 0.1250 X.XX ± 0.0625 X.XXX ± 0.0313 ANGULAR: ± 1° FRACTIONAL ± 1/16" | DRAWN SMB 08/31/2015 | NAME DATE | TICO/TERMINAL SERVICE 66 CYPRESS RIDGE DR. RIDGELAND, SC 29936 (843) 717-2226 |
| | REVISED MPC 07/05/2016 | APPROVED | |
| | DO NOT SCALE DRAWING | | |
| | TITLE: ASSEMBLY, CAB HEATER QSB IVi | | |
| INTERPRET GEOMETRIC TOLERANCING PER: ASME 14.5M-1994 | THE SUBJECT MATTER SHOWN AND DESCRIBED IN THIS DRAWING AND ANY OTHER INFORMATION ADVANCED IN CONNECTION THEREWITH, IS PROPRIETARY PROPERTY AND IS TO BE HELD IN STRICT CONFIDENCE BY YOU. ALL RIGHTS TO ANY INVENTIONS, DESIGNS, TRADE MARKS, TRADE NAMES AND COPYRIGHTS DISCLOSED ARE RESERVED TO TICO TERMINAL SERVICES, INC. | | SIZE B |
| MATERIAL | DWG. NO. 721188-A1 | REV | SHEET 1 OF 1 |
| FINISH | | | |
| THICKNESS | | | |

| TICO PRO-SPOTTER | | | | |
|------------------|------------|---------------------------|---|--------|
| S/N: | | ASSEMBLY, HEATER, QSB IVi | | 721188 |
| ITEM | PART # | QTY/M | DESCRIPTION | |
| | 721188-A1 | REF | ASSEMBLY, HEATER, QSB IVi | |
| | 62403 | REF | SCHEMATIC, A.C. SYSTEM, ACC HI-LO PRESSURE SWITCH, FAN CLUTCH | |
| | 920099 | REF | ASSEMBLY, DASH PANEL, HEATER, ELECTRONIC CONTROL, THERMA TECH | |
| | 620596 | REF | HARNESS, WIRE, HEATER/AC, ELECTRONIC CONTROLS, ROCKER SWITCH | |
| 1 | 920057 | 1 | MODULE, HEATER, ELECTRONIC CONTROL (WITH WATER VALVE) | |
| 2 | 920059 | 1 | ASSEMBLY, PLENUM, ELECTRONIC CONTROLS | |
| 3 | 91722-16 | 1 | ADAPTER, HOSE, 3" TO 2-1/2" | |
| NOT SHOWN | 91722-6 | 2 FT | HOSE, ULTRA SMOOTH, 2-1/2" ID | |
| NOT SHOWN | 20337 | 2 | CLAMP, WORMGEAR, LINER, 2-1/2" DIAMETER HOSE | |
| 4 | 91722-26 | 2-1/2 FT | HOSE, FLEX, 3" | |
| | 91722-26 | 1-3/4 FT | HOSE, FLEX, 3" | |
| | 91722-26 | 1 FT | HOSE, FLEX, 3" | |
| 5 | 42299 | 6 | CLAMP, WORMGEAR, LINER, HOSE, 3" DIAMETER | |
| 6 | 91722-4 | 6 FT | HOSE, FLEX, 2" | |
| | 91722-4 | 5 FT | HOSE, FLEX, 2" | |
| 7 | 42157 | 4 | CLAMP, WORMGEAR, LINER, HOSE, 2" DIAMETER | |
| 8 | 91783 | 1 | DEFROSTER, MANIFOLD, LEFT-HAND | |
| 9 | 800428 | 2 | SCREW, FLAT HEAD, PHILLIPS, #12 X 2-1/2 LONG | |
| 10 | 800431 | 2 | WASHER, FINISHING, NICKEL PLATED, #12 | |
| 11 | 91828 | 1 | DEFROSTER, MANIFOLD, RIGHT-HAND | |
| 12 | 82392 | 2 | BOLT, HEX HEAD, 1/4-20 X 1-1/2 LONG | |
| 13 | 80129 | 6 | WASHER, FENDER, 1/4-20 X 1-1/4 LONG | |
| 14 | 80303 | 3 | GROMMET, RUBBER, 1/2 X 5/8 X 5/16 HOLE | |
| 15 | 85089 | 2 | WASHER, FLAT, 1/4 | |
| 16 | 85023 | 2 | LOCKNUT, NYLON, 1/4-20 | |
| 17 | 91722-13 | 2 | LOUVER, 2-1/2" (NO ADAPTER BALL) | |
| NOT SHOWN | 91722-14 | 2 | ADAPTER, BALL LOUVER, HOSE, 2" | |
| 18 | 91722-15 | 2 | RING, LOUVER TRIM | |
| 19 | 800429 | 2 | SCREW, SHEET METAL, PAN HEAD, PHILLIPS, STAINLESS STEEL, #10 X 1/2 LONG | |
| 20 | 91722-18 | 1 | LOUVER, DOWNDRAFT, FIXED, 3" | |
| 21 | 800430 | 4 | SCREW, SHEET METAL, PAN HEAD, PHILLIPS, STAINLESS STEEL, #10 X 3/4 LONG | |
| 22 | 91722-17 | 1 | ADAPTER, HOSE, FLANGED, 3" | |
| 23 | 800429 | 2 | SCREW, SHEET METAL, PAN HEAD, PHILLIPS, STAINLESS STEEL, #10 X 1/2 LONG | |
| 24 | 920011 | 1 | FILTER, HEATER/AC, PERMATRON, 20 1/2 X 8 | |
| NOT SHOWN | 42149 | 2 | CLAMP, WORMGEAR, LINER, 5/8" HOSE | |
| NOT SHOWN | 12067 | 1 | BRACKET, STANDOFF (HEATER LINES) | |
| REV | DATE | BY | | SHEET |
| A | 07/05/2016 | MPC | | 1 OF 1 |