

3 4 5  
2X

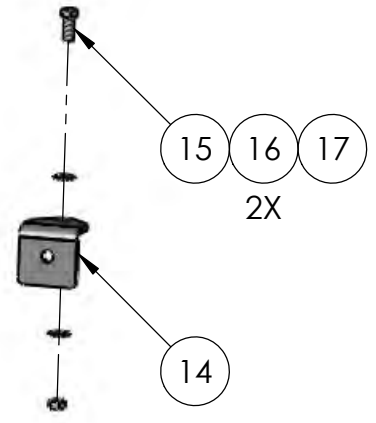

15 16 17  
2X

DETAIL A  
SCALE 1 : 1

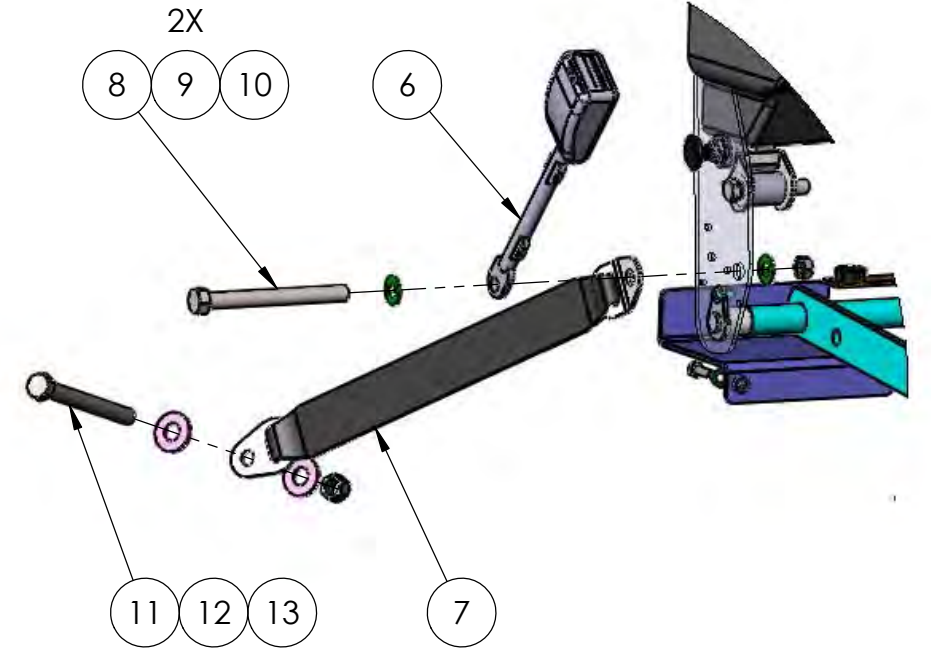
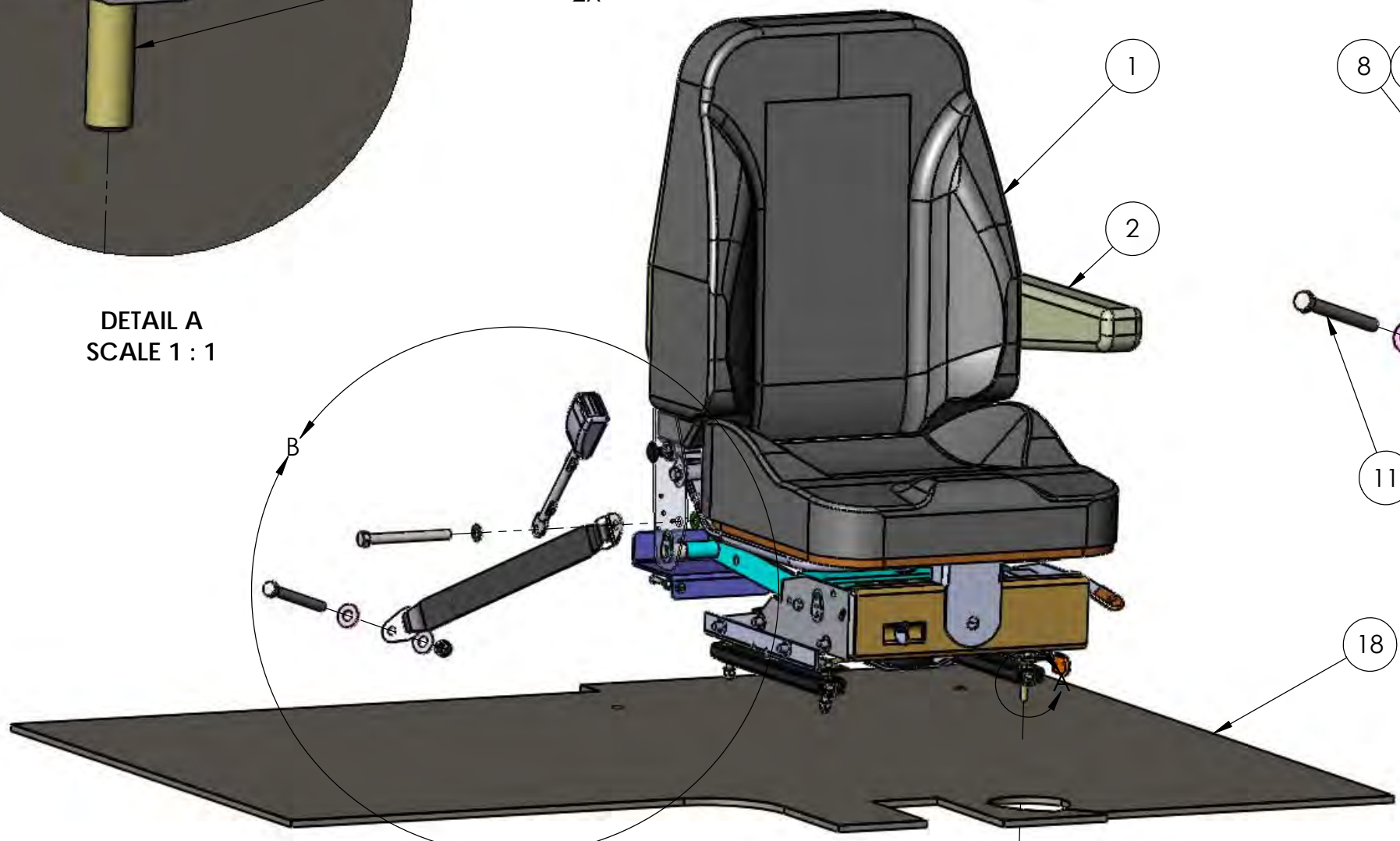

2X  
8 9 10 6  
11 12 13  
2X  
7

DETAIL B  
SCALE 1 : 6

DIMENSIONS ARE IN INCHES		NAME	DATE	 TICO/TERMINAL SERVICE 66 CYPRESS RIDGE DR. RIDGELAND, SC 29936 (843) 717-2226	
TOLERANCES:		DRAWN	SMB 03/11/2015		
DECIMAL:		REVISED	MPC 07/07/2016		
X.X ± 0.06 X.XX ± 0.03 X.XXX ± 0.005		APPROVED			
ANGULAR: ± 0.5°		DO NOT SCALE DRAWING		TITLE:	
FRACTIONAL ± 1/32"				SEAT, BOSTROM	
INTERPRET GEOMETRIC TOLERANCING PER: ASME 14.5M-1994		THE SUBJECT MATTER SHOWN AND DESCRIBED IN THIS DRAWING AND ANY OTHER INFORMATION ADVANCED IN CONNECTION THEREWITH, IS PROPRIETARY PROPERTY AND IS TO BE HELD IN STRICT CONFIDENCE BY YOU. ALL RIGHTS TO ANY INVENTIONS, DESIGNS, TRADE MARKS, TRADE NAMES AND COPYRIGHTS DISCLOSED ARE RESERVED TO TICO TERMINAL SERVICES, INC.		SIZE	
MATERIAL				DWG. NO.	REV
FINISH				721152-A1	
THICKNESS					
				SHEET 1 OF 1	

