

**SURGE TANK &
HOSES
PAGE 3**

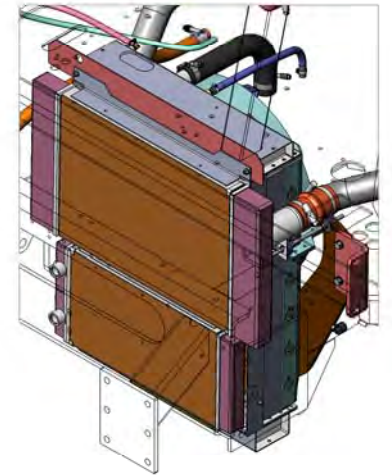

**RADIATOR &
SHROUD
PAGE 2**

DIMENSIONS ARE IN INCHES		NAME	DATE
TOLERANCES:		DRAWN	MAL
DECIMAL:		CHECKED	
XX	± 0.06	APPROVED	
XXX	± 0.03	DO NOT SCALE DRAWING	
XXXX	± 0.005	THE SUBJECT MATTER SHOWN AND DESCRIBED IN THIS DRAWING AND ANY OTHER INFORMATION ADVANCED IN CONNECTION THEREWITH IS PROPRIETARY PROPERTY AND IS TO BE HELD IN STRICT CONFIDENCE BY YOU. ALL RIGHTS TO ANY INVENTIONS, DESIGN, TRADE MARKS, TRADE NAMES AND COPYRIGHTS DECLARED ARE RESERVED TO TICO TERMINAL SERVICE, INC.	
ANGULAR:	± 0.5°	TICO/TERMINAL SERVICE 66 CYPRESS RIDGE DR. RIDGELAND, SC 29936 (843) 717-2226	
FRACTIONAL:	± 1/32"	TITLE: COOLING SYSTEM, 2015-ISB	
INTERPRET GEOMETRIC TOLERANCING PER: ASME Y14.5M-1994	SEE NOTE	SIZE	DWG. NO.
MATERIAL	N/A	C	721119-A1
FINISH		SCALE: 1:32	WEIGHT: 3360.42 SHEET 1 OF 3
THICKNESS	N/A	REV	

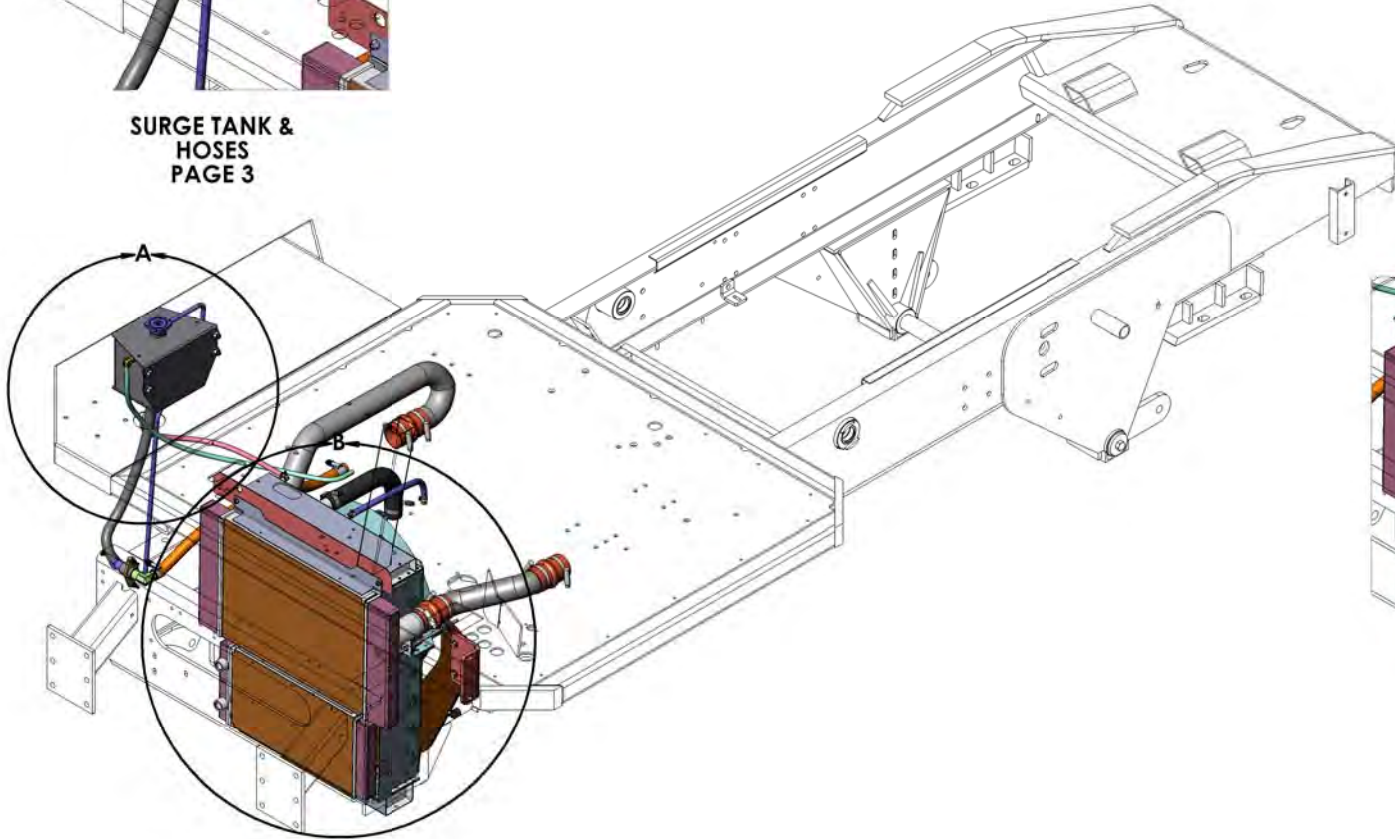
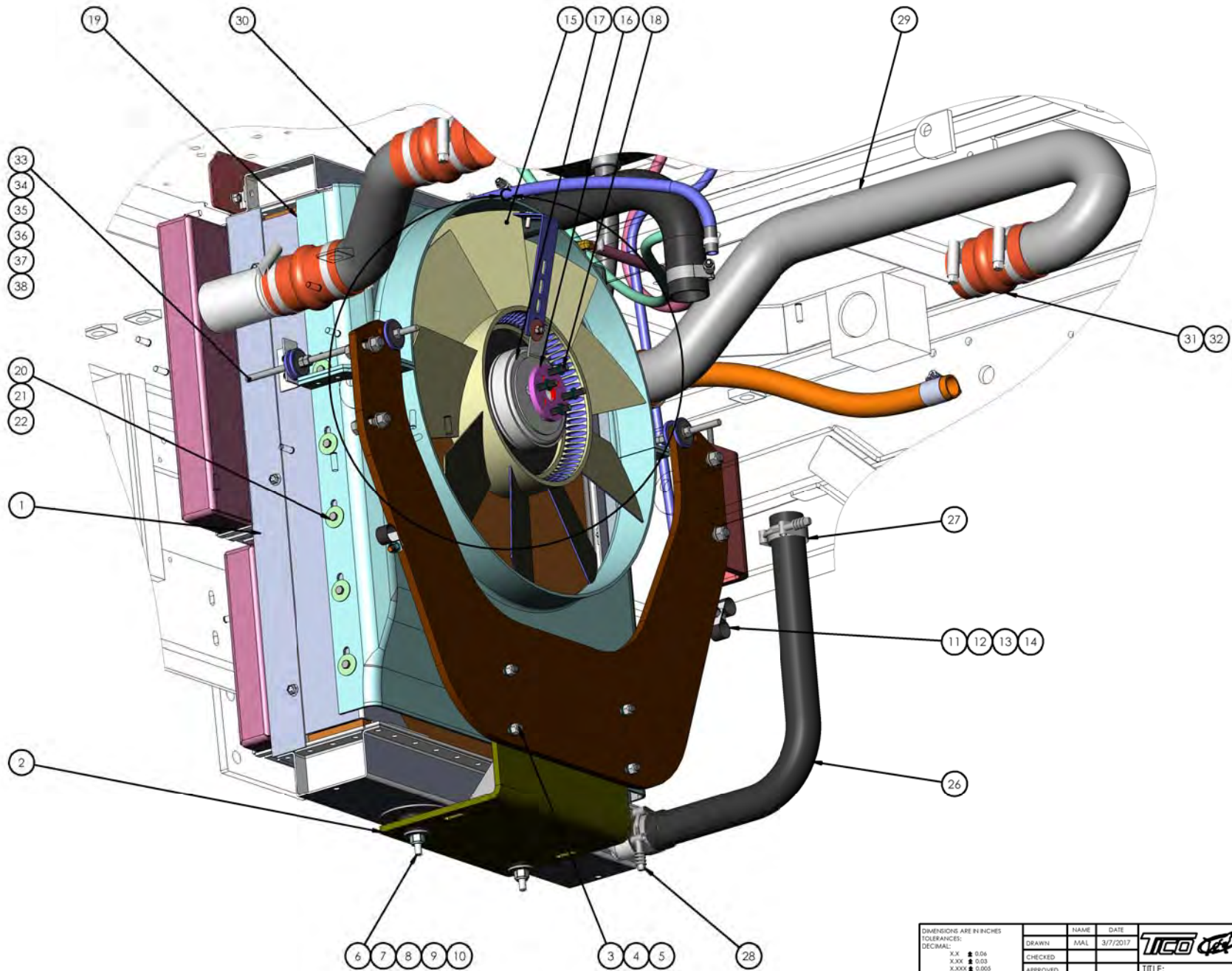

DIMENSIONS ARE IN INCHES		NAME	DATE
TOLERANCES:		DRAWN	MAL
DECIMAL:		CHECKED	
XX	± 0.06	APPROVED	
XXX	± 0.03	DO NOT SCALE DRAWING	
XXXX	± 0.005	THE SUBJECT MATTER SHOWN AND DESCRIBED IN THIS DRAWING AND ANY OTHER INFORMATION ADVANCED IN CONNECTION THEREWITH IS PROPRIETARY PROPERTY AND IS TO BE HELD IN STRICT CONFIDENCE BY YOU. ALL RIGHTS TO ANY INVENTIONS, DESIGN, TRADE MARK, TRADE NAME AND COPYRIGHTS DECLARED ARE RESERVED TO TICO TERMINAL SERVICES, INC.	
ANGULAR:	± 0.5°	TICO/TERRMINAL SERVICE 66 CYPRESS RIDGE DR. RIDGELAND, SC 29936 (843) 717-2226	
FRACTIONAL:	± 1/32"	TITLE: COOLING SYSTEM, 2015-ISB	
PREPARE GEOMETRIC TOLERANCING PER: ASME Y14.5M-1994	SIZE DWG. NO. REV		
MATERIAL	C 721119-A1		
FINISH	SCALE: 1:32 WEIGHT: 3360.4 SHEET 2 OF 3		
SEE NOTE			
FINISHES			
N/A			

8 7 6 5 4 3 2 1

F
E
D
C
B
A

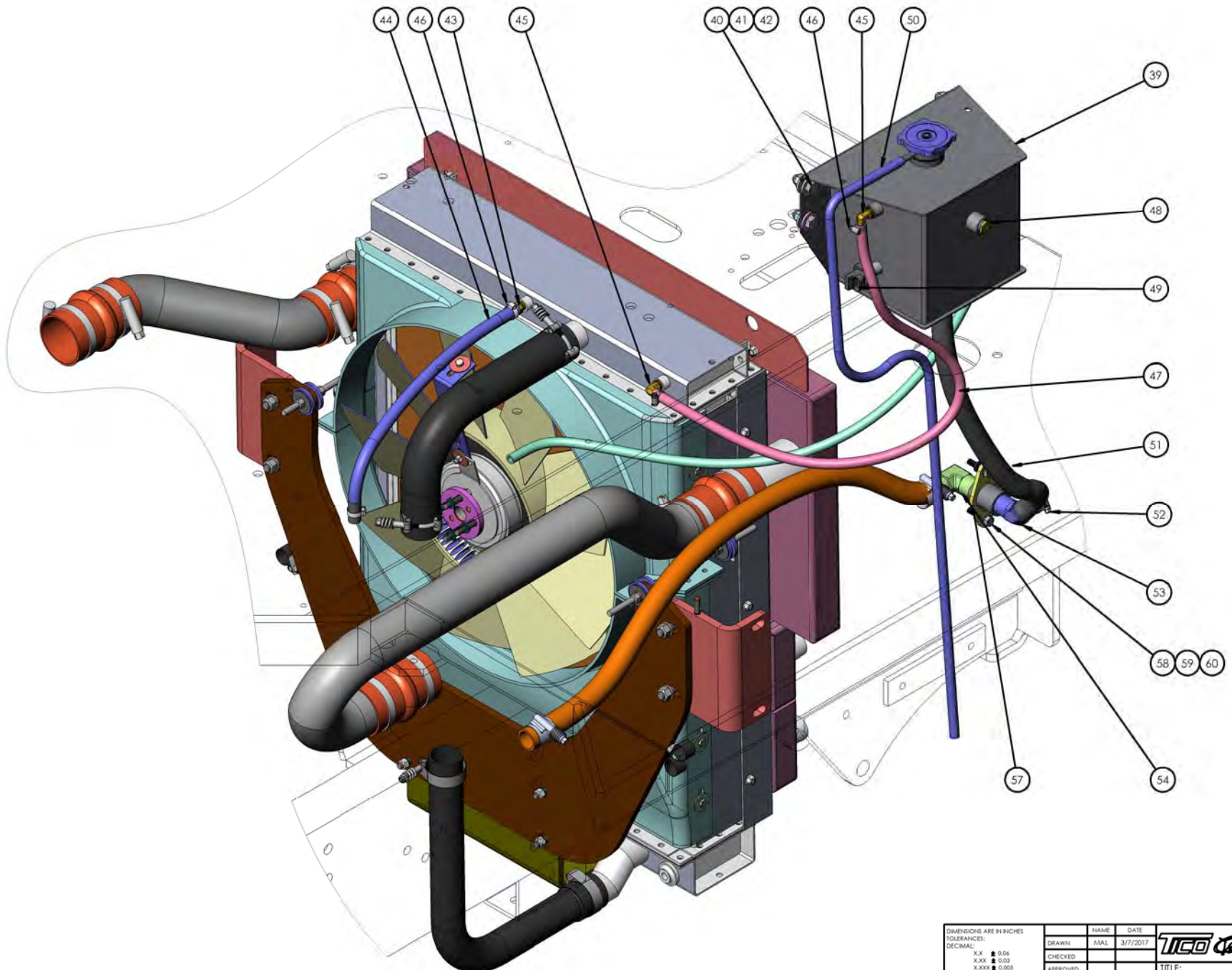

DIMENSIONS ARE IN INCHES		NAME	DATE
TOLERANCES:		DRAWN	MAL
DECIMAL:		CHECKED	
XX	± 0.06	APPROVED	
XXX	± 0.03	DO NOT SCALE DRAWING	
XXXX	± 0.005	THE SUBJECT MATTER SHOWN AND DESCRIBED IN THIS DRAWING AND ANY OTHER INFORMATION ADVANCED IN CONNECTION THEREWITH IS PROPRIETARY PROPERTY AND IS TO BE HELD IN STRICT CONFIDENCE BY YOU. ALL RIGHTS TO ANY INVENTIONS, DESIGN, TRADE MARKS, TRADE NAMES AND COPYRIGHTS DECLARED ARE RESERVED TO TICO TERMINAL SERVICES, INC.	
ANGULAR:	± 0.5°	TICO/TERRMINAL SERVICE 66 CYPRESS RIDGE DR. RIDGELAND, SC 29936 (843) 717-2226	
FRACTIONAL:	± 1/32"	TITLE: COOLING SYSTEM, 2015-ISB	
INTERPRET GEOMETRIC TOLERANCING PER: ASME Y14.5M-1994	SIZE DWG. NO. REV		
MATERIAL: N/A	C 721119-A1		
FINISH: SEE NOTE	SCALE: 1:32 WEIGHT: 3360.4 SHEET 3 OF 3		
DRAWN: N/A			

8 7 6 5 4 3 2 1

TICO PRO-SPOTTER

COOLING SYSTEM, QSB-III, RADIATOR,CAC,CLUTCH FAN, RUBBER ISOLATORS

721119

ITEM	PART #	QTY/M	DESCRIPTION
	721119-A1	REF	COOLING SYSTEM, QSB-3 HIGHMOUNT
1	620586	1	RADIATOR ASSY - W/AC CONDENSER MTG - 1/2" STUDS,BAR/PLATE
2	12737	1	RADIATOR MOUNT, RUBBER ISOLATORS, QSB3
3	82405	4	BOLT, HEX 3/8-16 x 1-3/4" Lg BRKT to ENGINE MT
4	85091	8	WASHER, FLAT 3/8
5	85036	4	LOCKNUT - 3/8-16
6	62254	2	ISOLATOR - RADIATOR MOUNT
7	80346	4	WASHER, FENDER 3/8" ID x 1 1/2" OD
8	62110	2	WASHER - FRONT ENGINE MOUNT - BOTTOM
9	62332	2	WASHER - RADIATOR MOUNT TOP
10	85027	2	LOCKNUT, NYLON 1/2-13
11	85025	2	LOCKNUT, 3/8-16
12	85091	8	WASHER, FLAT 3/8
13	85014	2	NUT, HEX 3/8-16
14	40593	2	CLAMP, P 1.0
15	60908	1	FAN,ENG 22" 9 BLADE COMP 3.75 PW CLUTCH
16	62328	1	CAPTURE PLATE
17	60423	1	CLUTCH FAN ASSEMBLY
18	80373	4	BOLT - FLANGE CERRATED FULL THD 10mmX45mm LONG GRD 10.9
19	60988	1	FAN SHROUD
20	82370	8	BOLT, HEX 1/4-20 X 1" LG SHROUD SIDES
21	80129	12	WASHER, FENDER 1/4" ID x 1 1/4" OD
22	85034	12	LOCKNUT 1/4
23	40593	2	P-CLAMP
24	60607	1	HOSE, RADIATOR INLET - 2"
25	420304	2	CLAMP, "T" BOLT - 2"-2 5/16"
26	60890	1	HOSE, RADIATOR OUTLET - 2" X 25" LG
27	420310	1	CLAMP, "T" BOLT - 2 1/8"-2 7/16"
28	420305	1	CLAMP, "T" BOLT - 2 1/4"-2 9/16"
29	60995	1	TUBE, CAC OUTLET, QSB3 CRADLE
30	60996	1	TUBE, CAC INLET, QSB3 CRADLE
31	61660	4	HOSE, HUMP CAC 3" DIA
32	40185	8	CLAMP, SPRING HOSE
REV	DATE	BY	SHEET
B	03/07/2017	MAL	1 OF 2

