

DIMENSIONS ARE IN INCHES TOLERANCES:		NAME	DATE
DECIMAL	XXX.X	ACGW	06/03/2020
FRACTIONAL	1/16"	CHECKED	
		APPROVED	
DO NOT SCALE DRAWING			
ALL DIMENSIONS UNLESS OTHERWISE SPECIFIED IN THE DRAWING AND ANY CONFLICTS SHALL BE RESOLVED BY CONSULTING THE ORIGINAL DRAWING AND ANY REVISIONS. DIMENSIONS SHALL BE TO THE CENTER UNLESS OTHERWISE SPECIFIED. TRADE NAMES AND LOGOS SHALL BE SHOWN AS SUPPLIED BY THE MANUFACTURER. DIMENSIONS SHALL BE TO THE CENTER UNLESS OTHERWISE SPECIFIED.			
DATE	N/A	REV	
DESCRIPTION	SEE NOTE	REV	
REVISIONS	N/A	REV	

TICO MANUFACTURING
 14 CYPRESS RIDGE DR.
 ROCKFORD, SC 29136
 803.777.0226
 TITLE: DASH ASSY- QSB-RDS, KPH -
 12V-PUSH BUTTN- KEY
 SIZE: DWG. NO. 72058-C1
D SCALE: 1:4 WEIGHT: 19.69 SHEET 1 OF 1

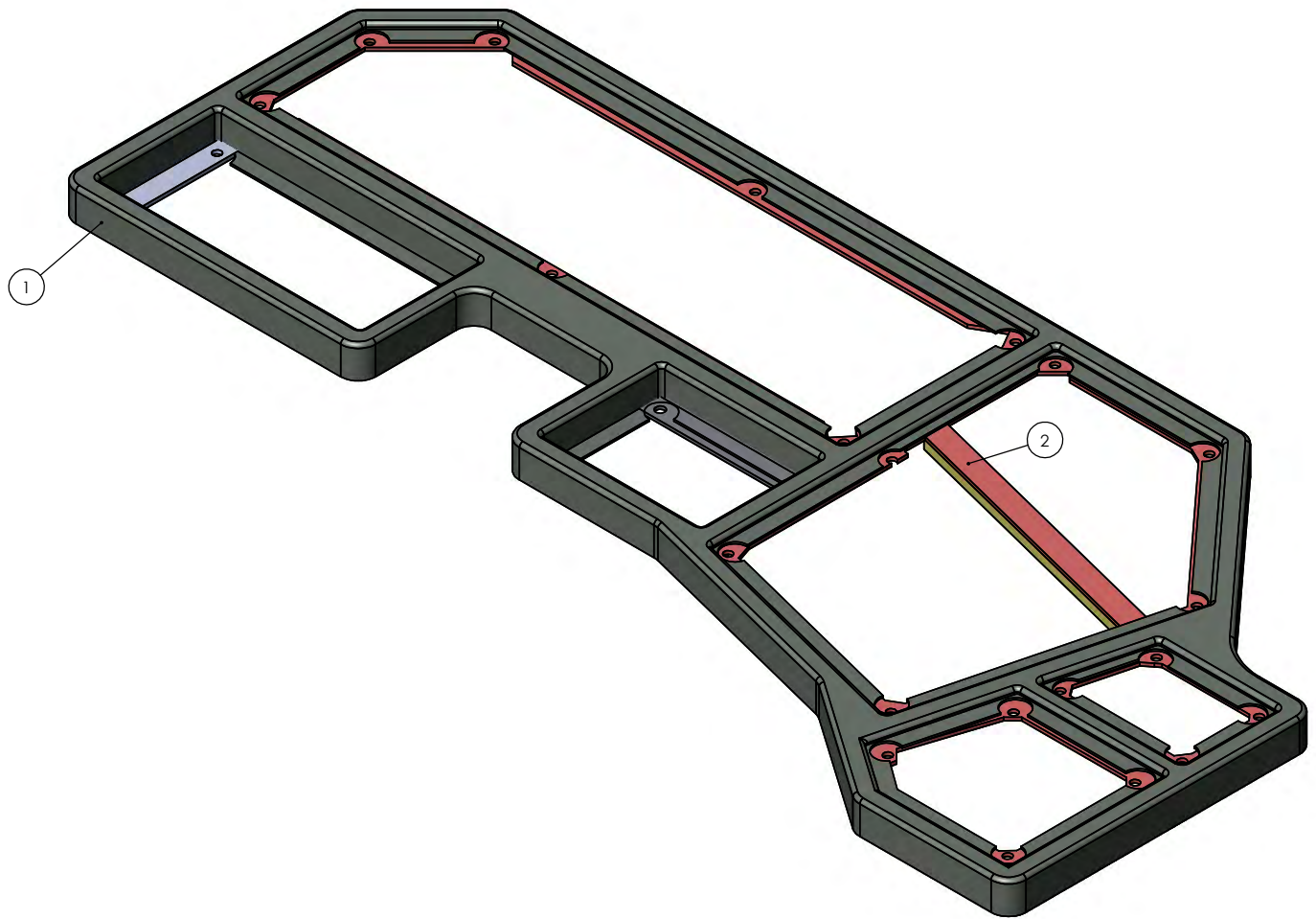

DIMENSIONS ARE IN INCHES		NAME	DATE	TICO MANUFACTURING	
TOLERANCES:		DRAWN	ADW	06/22/2020	44 CYPRESS RIDGE DR.
DECIMAL	.005	CHECKED			ROCKLAND, NC 29154
FRACTIONAL	1/32	APPROVED			TICORACTORS.COM
ANGULAR	±0.1°	DO NOT SCALE DRAWING			
INSURE GEOMETRIC TOLERANCING PER ASME Y14.5M					
THE SUBJECT MATTER SHOWN AND DESCRIBED IN THIS DRAWING AND ANY OTHER INFORMATION CONTAINED IN CONNECTION HEREWITH IS TO BE REPRODUCED IN WHOLE OR IN PART WITHOUT THE WRITTEN CONSENT OF TICO MANUFACTURING AND CONFORMS TO THE DRAWING AND ANY INFORMATION CONTAINED THEREIN. ALL RIGHTS TO ANY PATENTS, TRADEMARKS, AND COPYRIGHTS NOTICED ARE RESERVED BY TICO MANUFACTURING, INC.					
TITLE: DASH COVER ASSEMBLY ISB 10		SIZE	DWG. NO.	REV	
		D	91646-A1 ILL		
SCALE: 1:4		WEIGHT: 7.29	SHEET 1 OF 1		

D 91646-A1 ILL 10/1

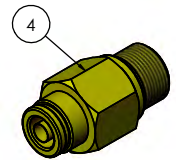
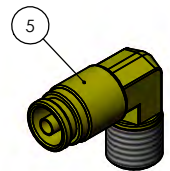
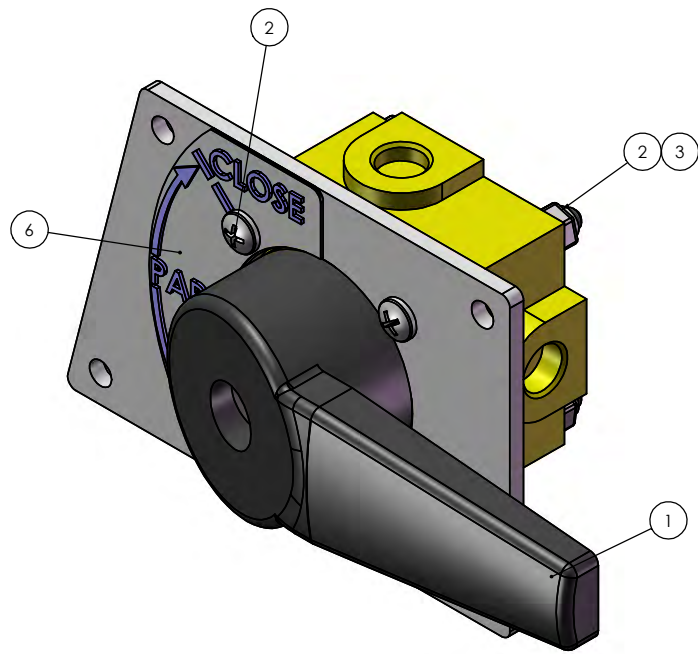

DIMENSIONS ARE IN INCHES		NAME	DATE	TICO MANUFACTURING
TOLERANCES:	DECIMAL	DRAWN	ADW	06/22/2020
	.005	CHECKED		44 CYPRESS RIDGE DR.
	.010	APPROVED		ROCKLAND, NC 27854
	.015			TICORACTORS.COM
	.030			
	.060			
	.125			
ANGULAR:	± 1.0°	DO NOT SCALE DRAWING		
FUNCTIONAL:	± 1.0°	THE SUBJECT MATTER SHOWN AND		
		DESCRIBED IN THIS DRAWING AND ANY		
		OTHER REFERENCE IS UNLESS IN		
		CONNECTION OTHERWISE TO BE		
		RECORDED PROTECTIVE EVIDENCE		
		ALL RIGHTS TO ANY INVENTIONS		
		HEREIN, INCLUDING PATENT RIGHTS		
		MAINTAINED AND OTHERWISE DISCLOSED		
		ARE RESERVED BY TICO MANUFACTURING		
		OR ITS AFFILIATES.		
TICO		TITLE:		ASSEMBLY, PANEL DASH
DOOR VALVE		SIZE:		D
DWG. NO.:		REV:		20183-A1 ILL
SCALE: 1:1		WEIGHT:		SHEET 1 OF 1

D 20183-A1 ILL

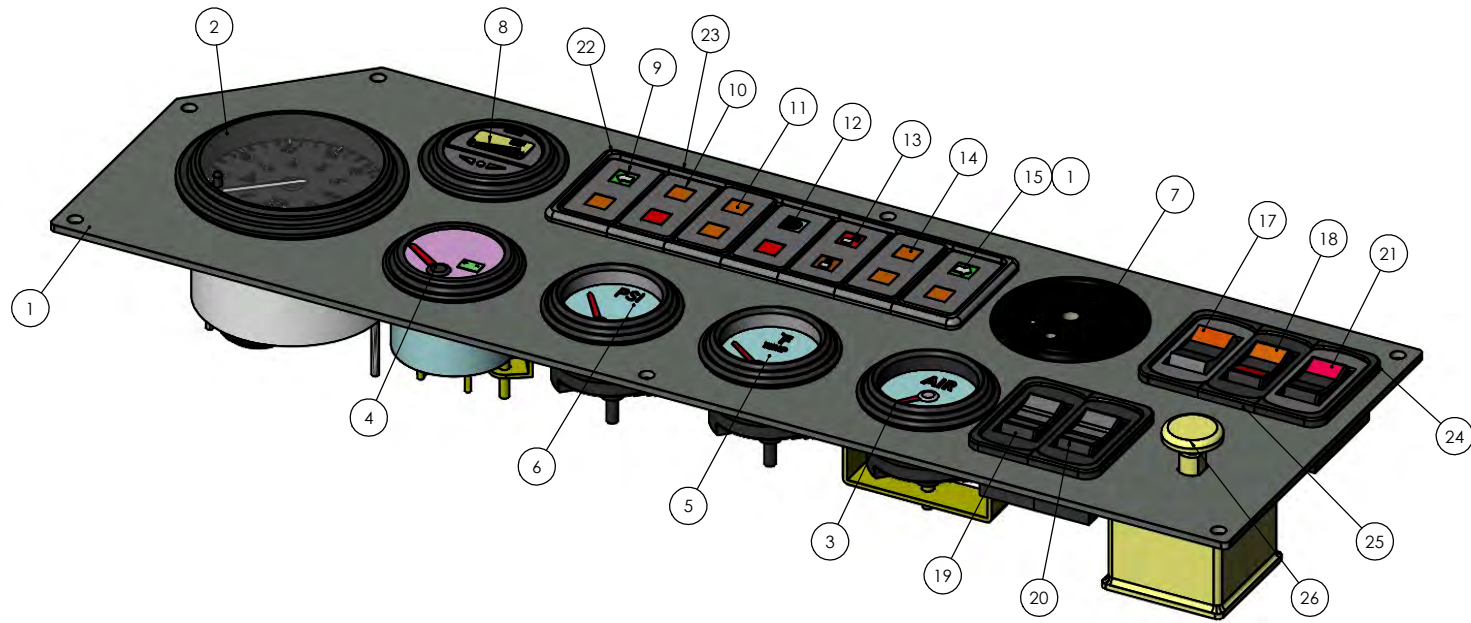

DIMENSIONS ARE IN INCHES		NAME	DATE	TICO MANUFACTURING
TOLERANCES:	DECIMAL	DRAWN	ADW	06/22/2020
	.005	CHECKED		44 CYPRESS RIDGE DR.
	.010	APPROVED		ROCKLAND, NC 27854
	.015			TICORACTORS.COM
	.030			
ANGULAR:	± 1.0°	DO NOT SCALE DRAWING		
FRACTONAL:	± .005	THE SUBJECT MATTER SHOWN AND		
		DESCRIBED IN THIS DRAWING AND ANY		
		OTHER REFERENCE IS ADVANCED BY		
		CONTRACTOR INSTRUMENTS, U.S.A.		
		INSTRUMENTS TO BE USED TO BE		
		REPRODUCED IN ANY MANNER WITHOUT		
		WRITTEN PERMISSION FROM TICO		
		MANUFACTURING. TICO		
		MAKES NO WARRANTY OR		
		ASSUMES NO LIABILITY FOR		
		DAMAGE OR CONSEQUENCES		
		RESULTING FROM THE USE OF		
		THIS DRAWING.		
DATE:	N/A			
DESIGNER:	SEE NOTE			
DRAWN:	N/A			
CHECKED:	N/A			
APPROVED:	N/A			
TITLE:		ASSY PANEL DASH GAUGE -		
SIZE:		2013-18 MPH SPEEDOM INT		
DWG. NO.:		WIPER		
REV:				
SCALE:		1:2		
WEIGHT:		2.23		
SHEET:		1 OF 1		

20266-A1 ILL

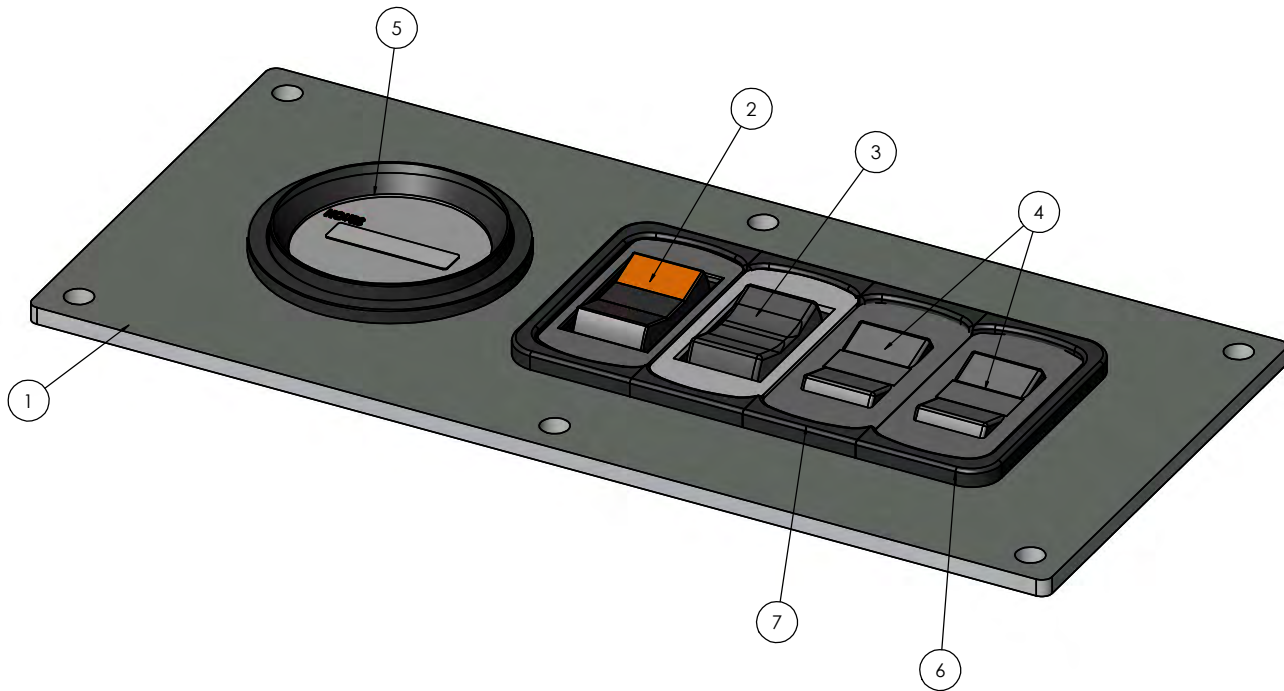

DIMENSIONS ARE IN INCHES		NAME	DATE
TOLERANCES UNLESS OTHERWISE SPECIFIED		DRAWN	AGW 04/09/2020
GENERAL	XX ± 0.04	CHECKED	
	XXX ± 0.05		
ANGULAR	± 0.05	APPROVED	
RECTILINEAR	± 0.05		
	± 0.05		
DO NOT SCALE DRAWING			
INTERFERE GEOMETRIC TOOLERANCING PER ASME Y14.5M			
THE SUBJECT MATTER SHOWN AND DESCRIBED IN THE DRAWING AND ANY OTHER INFORMATION ADVANCED BY TECHNICAL PERSONNEL IS TO BE HELD STRICTLY CONFIDENTIAL TO THE QUALITY MANAGER SERVICE. NAMES AND COPYRIGHTS DISCLOSED ARE RESERVED BY THE DRAWING MANAGER.			
SCALE:	1:1	WEIGHT:	0.48
TICKETS:		SHEET:	1 OF 1

TICO TICO MANUFACTURING
 64 CYPRESS RIDGE DR
 ROCKY HILL, CT 06067
 TICO@TICO-CT.COM

TITLE: **ASSY PANEL
 HOURMETER/DIAGNOSTIC -
 ISB**

SIZE: **D** DWG. NO.: **91780-A1** REV:

SCALE: 1:1 | WEIGHT: 0.48 | SHEET 1 OF 1

91780-A1

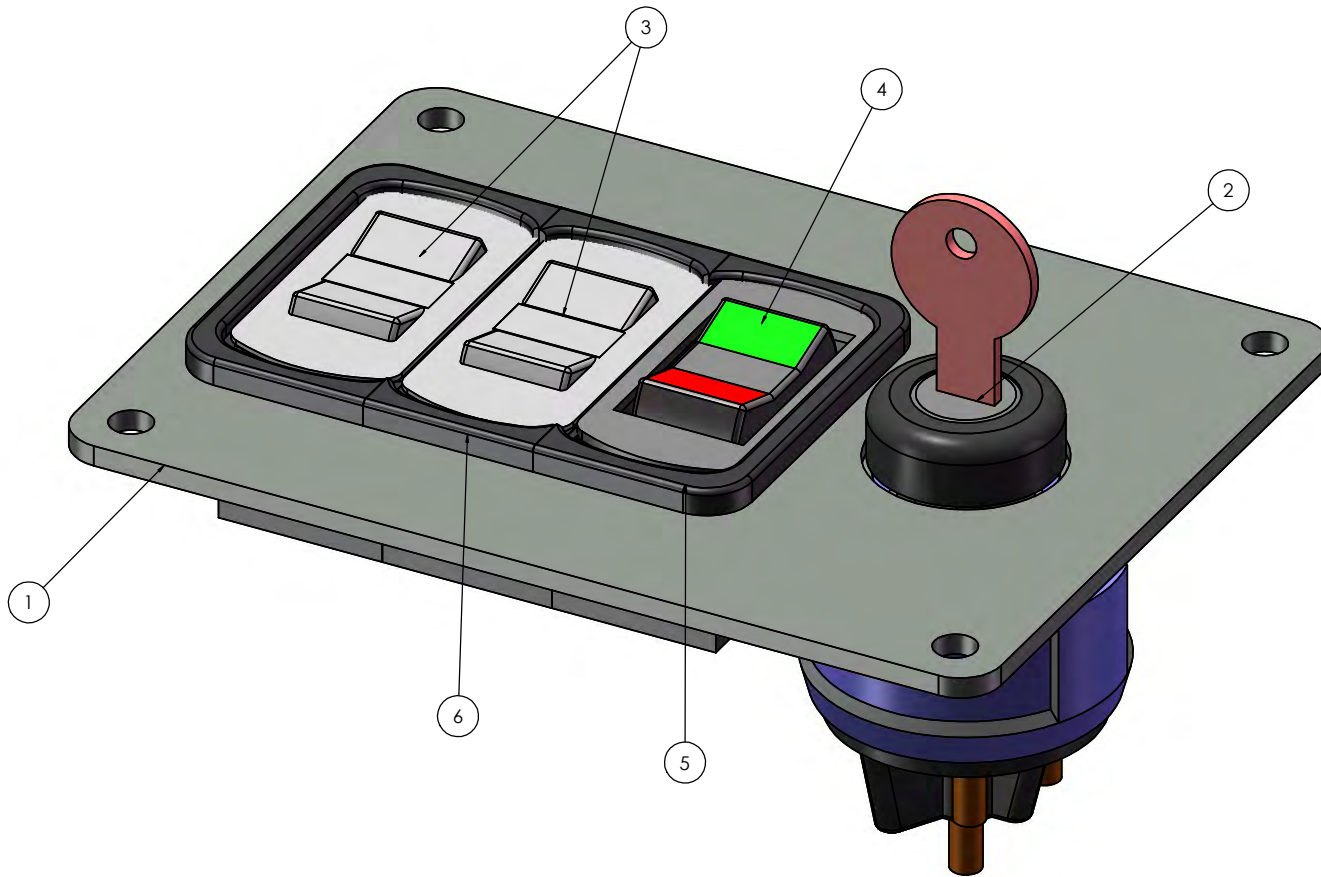

DIMENSIONS ARE IN INCHES TOLERANCES:		NAME	DATE	 TICO MANUFACTURING 14 CYPRESS BOULEVARD, SUITE 200 TICOFACTORY.COM
DECIMAL:	XX.XX	AGW	04/09/2020	
FRACTIONAL:	XX/XX			
ANGULAR:	XX°XX'			
HEAVY METAL DRAWING: DRAWING PER ASME 14.5M 1994	DO NOT SCALE DRAWING	TITLE: ASSEMBLY, DASH PANEL IGNITION SWITCH		
DATE:	REV: DWG. NO. 90405-A1	SIZE: D SCALE: 1:1 WEIGHT: SHEET 1 OF 1		
ISSUE:				
REVISIONS:				

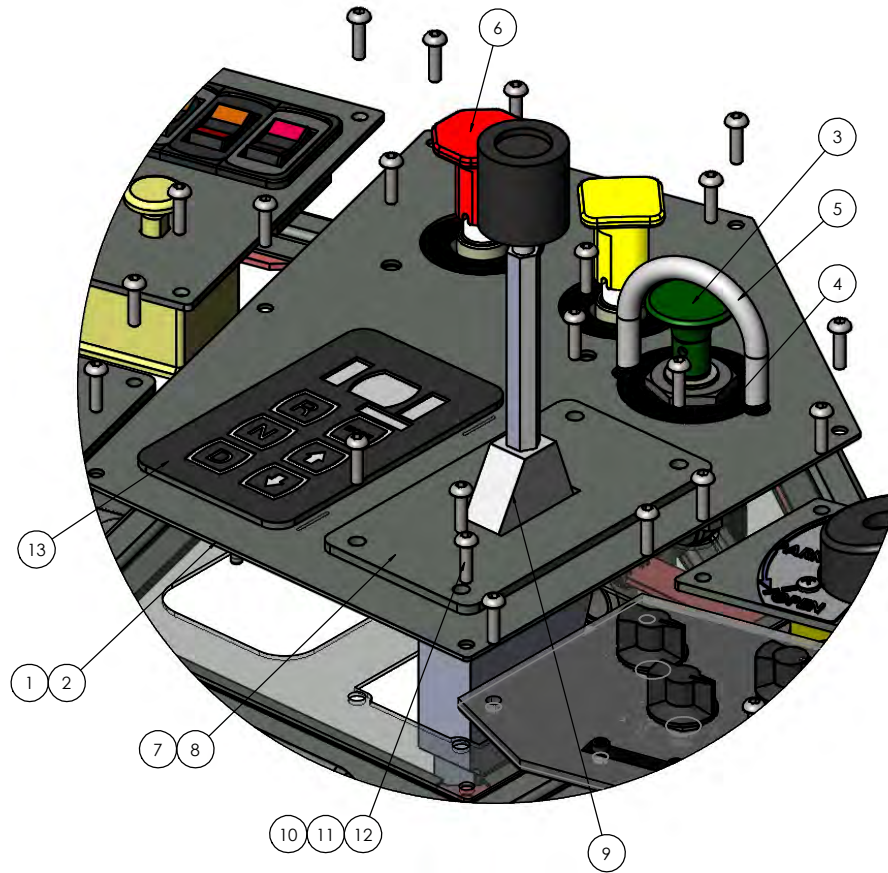

DRAWINGS ARE IN INCHES		NAME	DATE	TICO MANUFACTURING 66 CYPRESS RIDGE DR. ROSELAND, NC 27068 TICORFACTORS.COM
TOLERANCES:	DRAWN	AGW	04/22/2020	
FRACTIONAL	XXX	XXX	XXX	TICO THE SUBJECT MATTER SHOWN AND DESCRIBED IN THIS DRAWING AND ANY THEREIN IS THE PROPERTY OF TICO MANUFACTURING, INC. AND IS TO BE KEPT IN CONFIDENCE. ALL RIGHTS TO ANY PATENTS, TRADEMARKS, OR OTHER INTELLECTUAL PROPERTY ARE RESERVED TO TICO MANUFACTURING, INC.
DECIMAL	0.005	0.005	0.005	
ANGULAR	0.1°	0.1°	0.1°	APPROVED: _____ DO NOT SCALE DRAWING
DO NOT SCALE DRAWING				TITLE: DASH PANEL-P8 SHIFTER/HEATER/MV3/ELEC
SIZE	DWG. NO.	REV		
D	20196-A1			
SCALE: 1:4	WEIGHT: 23.22	SHEET 1 OF 1		



DIMENSIONS ARE IN INCHES		NAME	DATE	TICO MANUFACTURING	
TOLERANCES:		DRAWN	ADW	04/22/2020	44 CYPRESS RIDGE DR.
DECIMAL	.005	CHECKED			ROCKLAND, NC 27854
FRACTIONAL	1/32	APPROVED			TICORACTORS.COM
ANGULAR	± 0.1°	DO NOT SCALE DRAWING			
FUNCTIONAL	± 0.005	THE SUBJECT MATTER SHOWN AND			
INSURE GEOMETRIC TOLERANCING		DESCRIBED IN THIS DRAWING AND ANY			
PER ASME Y14.5M		OTHER REFERENCE IS INVOLVED IN			
UNLESS OTHERWISE SPECIFIED		CONSTRUCTION REQUIREMENTS TO BE			
ALL DIMENSIONS TO BE		FURNISHED TO THE CONTRACTOR BY THE			
DRAWING SHALL BE CONSIDERED		OWNER AND CONTRACTOR ACCEPTS			
AS SHOWN BY THIS DRAWING		REVISIONS			
		SIZE		DWG. NO.	REV
		D		20900-A1 ILL	
		SCALE: 1:1		WEIGHT: 0.27	SHEET 1 OF 1

D 20900-A1 ILL

