

**CHASSIS PDC & COVER
PAGE 3**

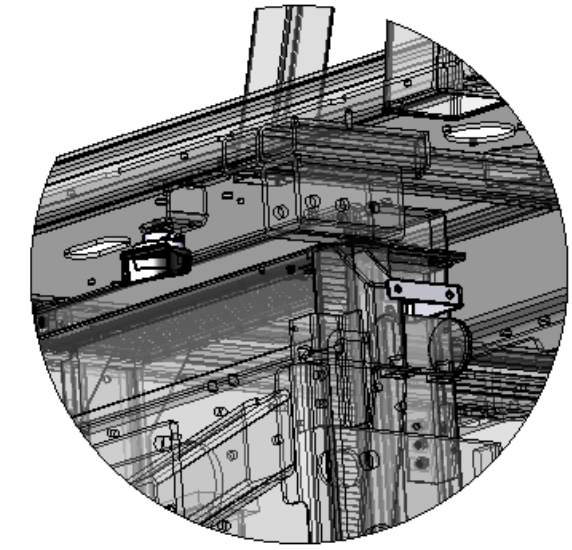

**HORN & WIRING BRACKET
PAGE 3**

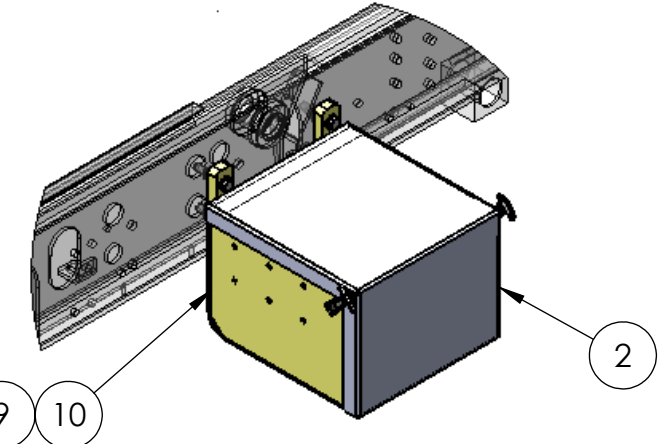
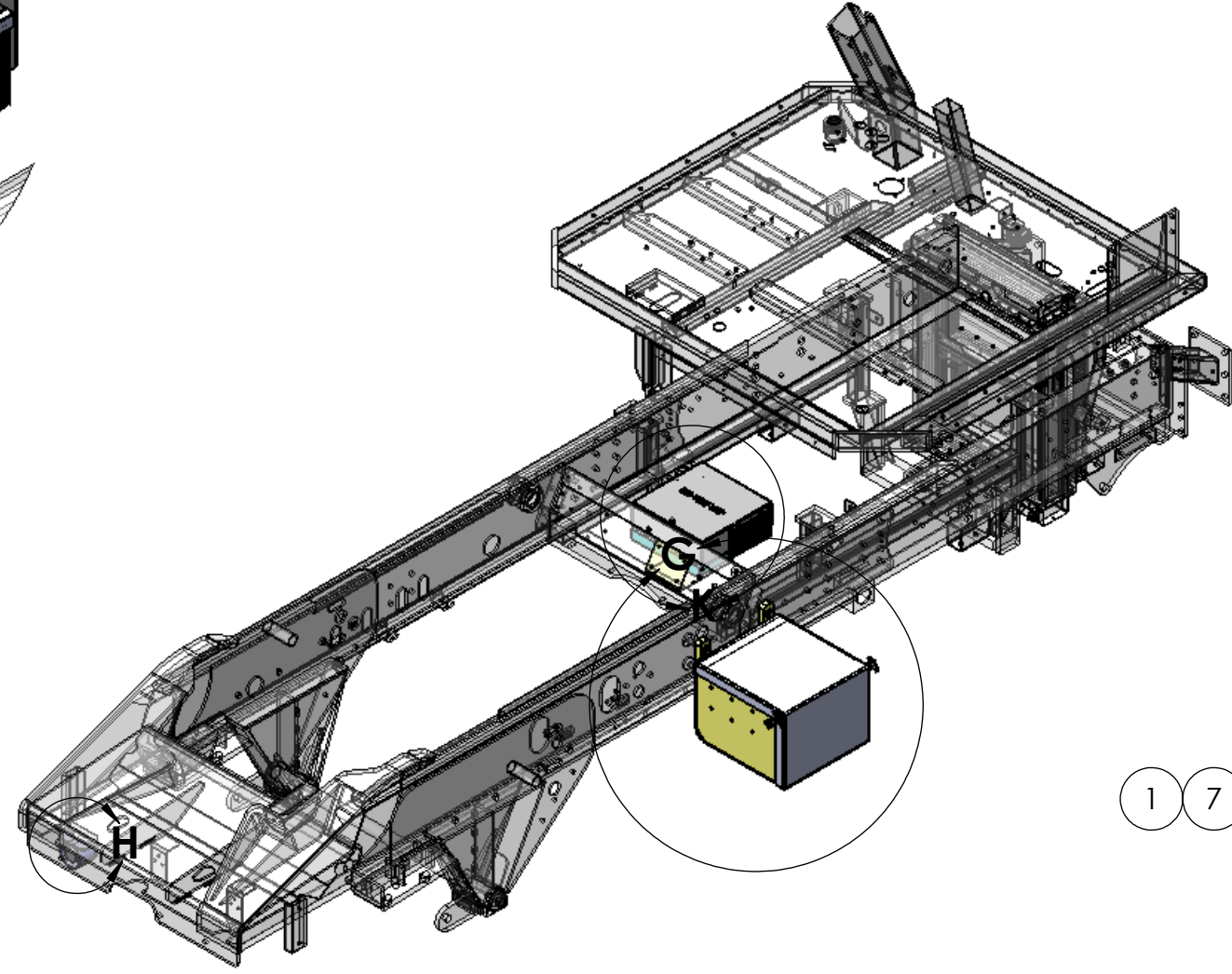

1 7 8 9 10
2X

**BATTERY BOX
PAGE 2**

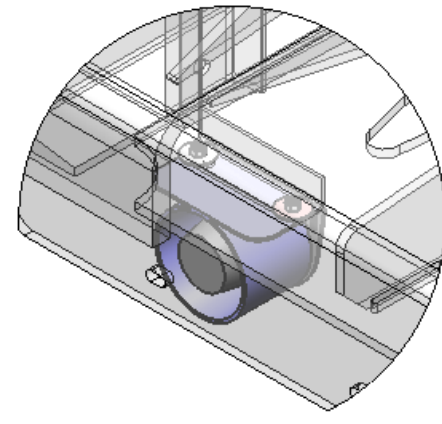

**BACKUP ALARM
PAGE 2**

DIMENSIONS ARE IN INCHES		NAME	DATE	 TICO/TERMINAL SERVICE 66 CYPRESS RIDGE DR. RIDGELAND, SC 29936 (843) 717-2226	
TOLERANCES:		DRAWN	MPC		5/4/2017
DECIMAL:		CHECKED			
X.X ± 0.06		APPROVED			
X.XX ± 0.03		DO NOT SCALE DRAWING			
X.XXX ± 0.005		TITLE: ASSEMBLY, BATTERY & WIRING			
ANGULAR: ± 0.5°		SIZE B DWG. NO. 721069-A1 REV			
FRACTIONAL: ± 1/32"		SCALE: 1:48 WEIGHT: SHEET 1 OF 3			
INTERPRET GEOMETRIC TOLERANCING PER: ASME 14.5M-1994		THE SUBJECT MATTER SHOWN AND DESCRIBED IN THIS DRAWING AND ANY OTHER INFORMATION ADVANCED IN CONNECTION THEREWITH, IS PROPRIETARY PROPERTY AND IS TO BE HELD IN STRICT CONFIDENCE BY YOU. ALL RIGHTS TO ANY INVENTIONS, DESIGNS, TRADE MARKS, TRADE NAMES AND COPYRIGHTS DISCLOSED ARE RESERVED TO TICO TERMINAL SERVICES, INC.			
MATERIAL					
FINISH					
THICKNESS					

8 7 6 5 4 3 2 1

D
C
B
A

D
C
B
A

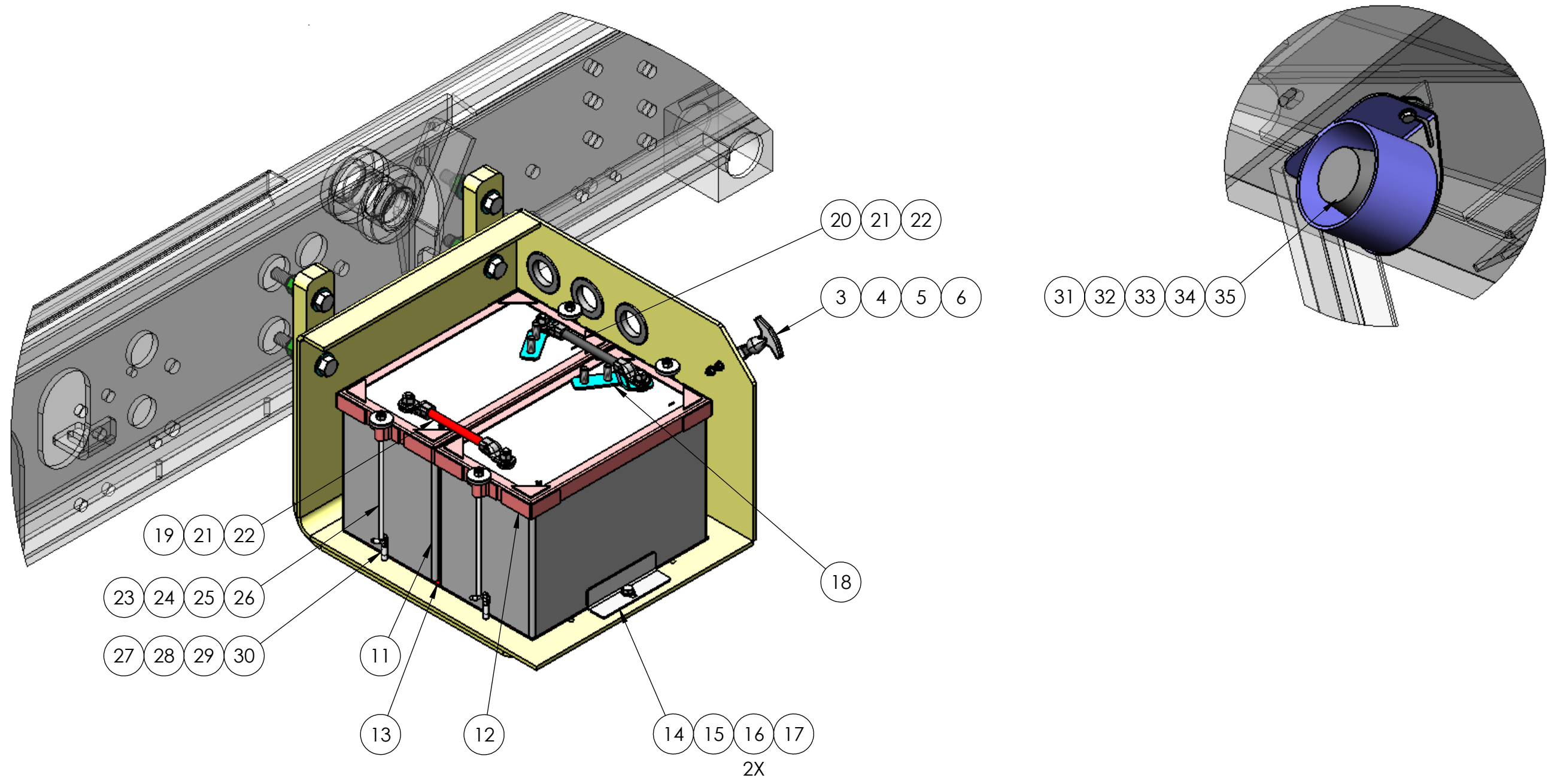

DIMENSIONS ARE IN INCHES TOLERANCES: DECIMAL: X.X ± 0.06 X.XX ± 0.03 X.XXX ± 0.005 ANGULAR: ± 0.5° FRACTIONAL ± 1/32"	NAME	DATE	 TICO/TERMINAL SERVICE 66 CYPRESS RIDGE DR. RIDGELAND, SC 29936 (843) 717-2226	
	DRAWN	MPC		5/4/2017
	CHECKED			
	APPROVED			
INTERPRET GEOMETRIC TOLERANCING PER: ASME 14.5M-1994	DO NOT SCALE DRAWING		TITLE: ASSEMBLY, BATTERY & WIRING	
FINISH	THE SUBJECT MATTER SHOWN AND DESCRIBED IN THIS DRAWING AND ANY OTHER INFORMATION ADVANCED IN CONNECTION THEREWITH, IS PROPRIETARY PROPERTY AND IS TO BE HELD IN STRICT CONFIDENCE BY YOU. ALL RIGHTS TO ANY INVENTIONS, DESIGNS, TRADE MARKS, TRADE NAMES AND COPYRIGHTS DISCLOSED ARE RESERVED TO TICO TERMINAL SERVICES, INC.		SIZE B DWG. NO. 721069-A1 REV	
THICKNESS	SCALE: 1:48	WEIGHT:	SHEET 2 OF 3	

8 7 6 5 4 3 2 1

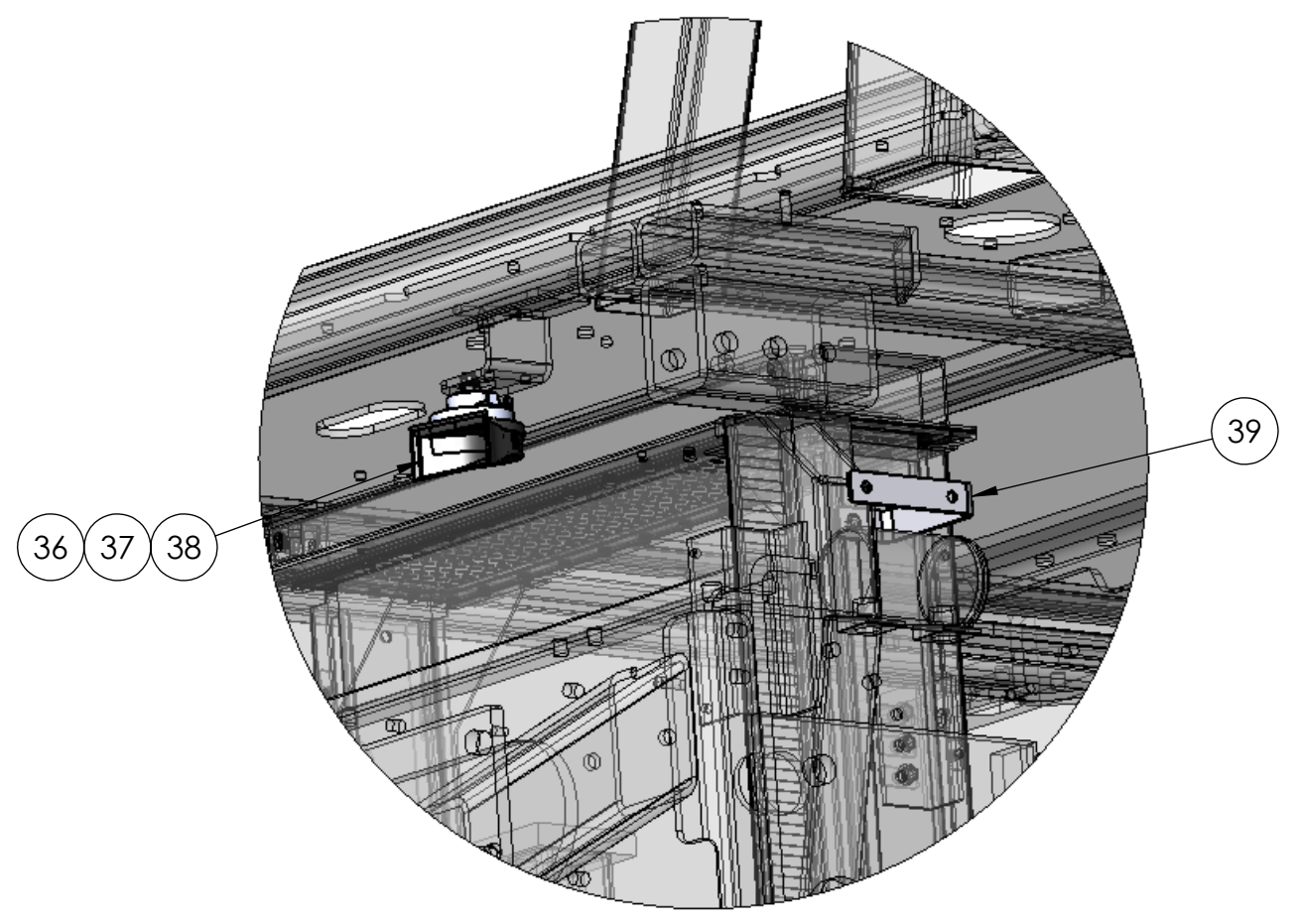
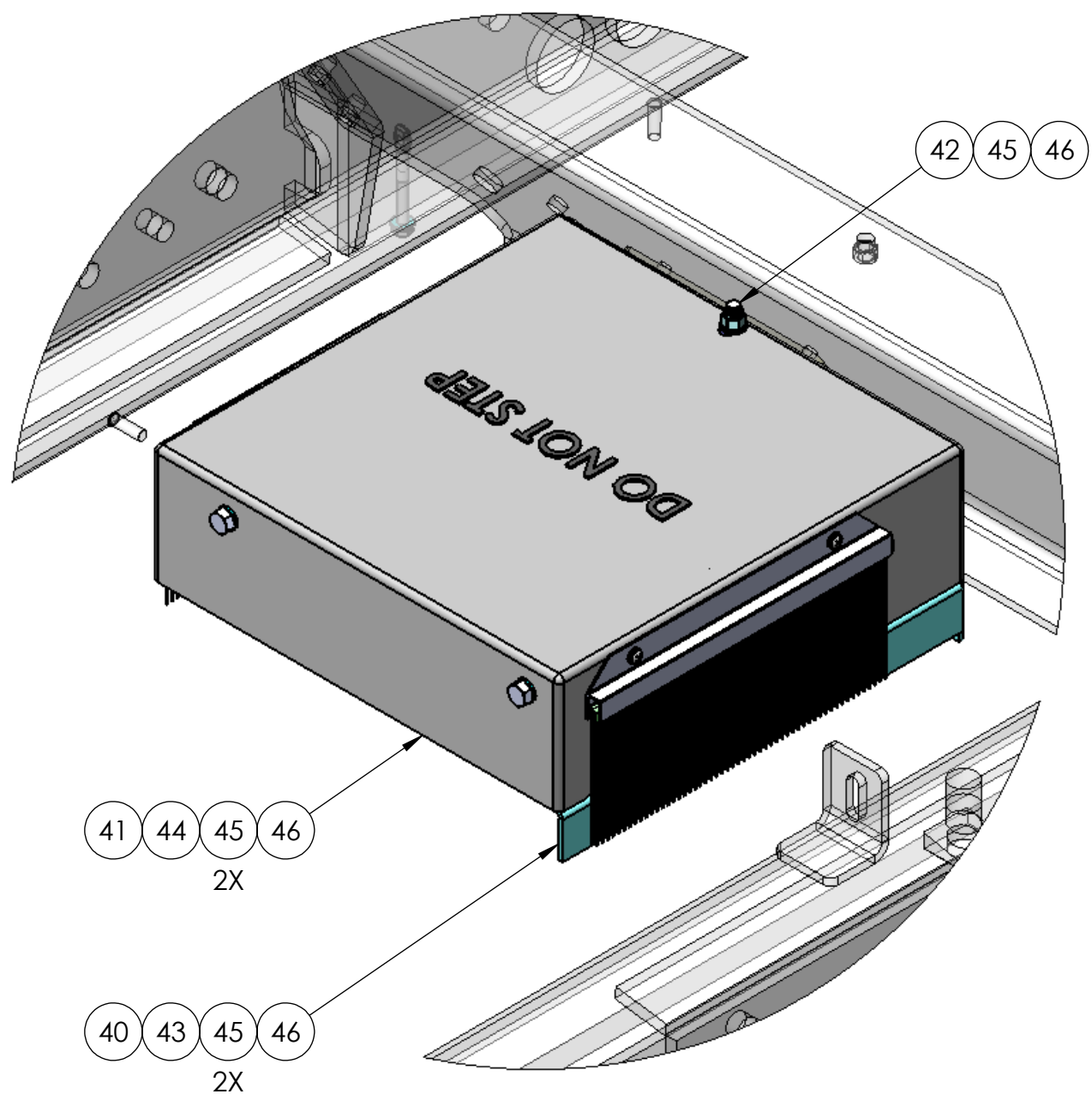

DIMENSIONS ARE IN INCHES TOLERANCES: DECIMAL: X.X ± 0.06 X.XX ± 0.03 X.XXX ± 0.005 ANGULAR: ± 0.5° FRACTIONAL ± 1/32"	NAME	DATE	 TICO/TERMINAL SERVICE 66 CYPRESS RIDGE DR. RIDGELAND, SC 29936 (843) 717-2226	
	DRAWN	MPC		5/4/2017
	CHECKED			
	APPROVED			
INTERPRET GEOMETRIC TOLERANCING PER: ASME 14.5M-1994	DO NOT SCALE DRAWING		TITLE: ASSEMBLY, BATTERY & WIRING	
MATERIAL FINISH THICKNESS	THE SUBJECT MATTER SHOWN AND DESCRIBED IN THIS DRAWING AND ANY OTHER INFORMATION ADVANCED IN CONNECTION THEREWITH, IS PROPRIETARY PROPERTY AND IS TO BE HELD IN STRICT CONFIDENCE BY YOU. ALL RIGHTS TO ANY INVENTIONS, DESIGNS, TRADE MARKS, TRADE NAMES AND COPYRIGHTS DISCLOSED ARE RESERVED TO TICO TERMINAL SERVICES, INC.		SIZE B DWG. NO. 721069-A1 REV	
	SCALE: 1:48	WEIGHT:	SHEET 3 OF 3	

