

**CHASSIS PDC & COVER
PAGE 3**

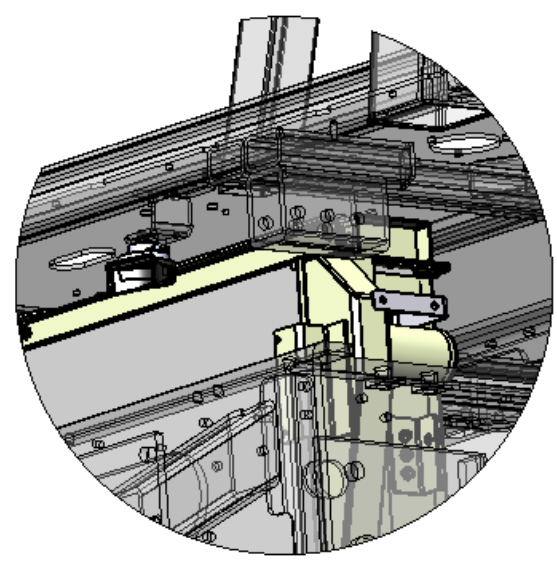

**HORN & WIRING BRACKET
PAGE 3**

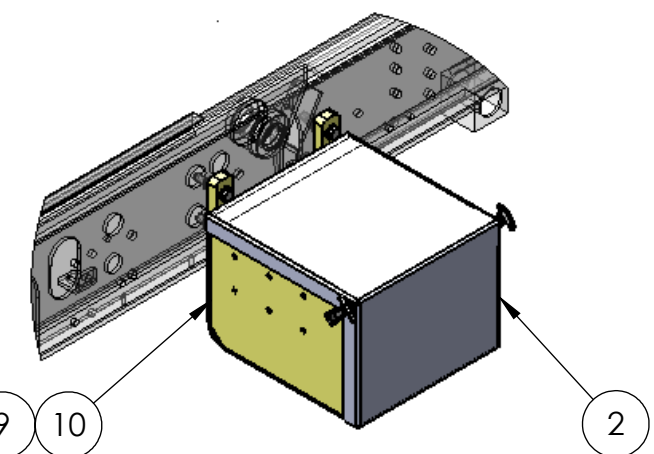
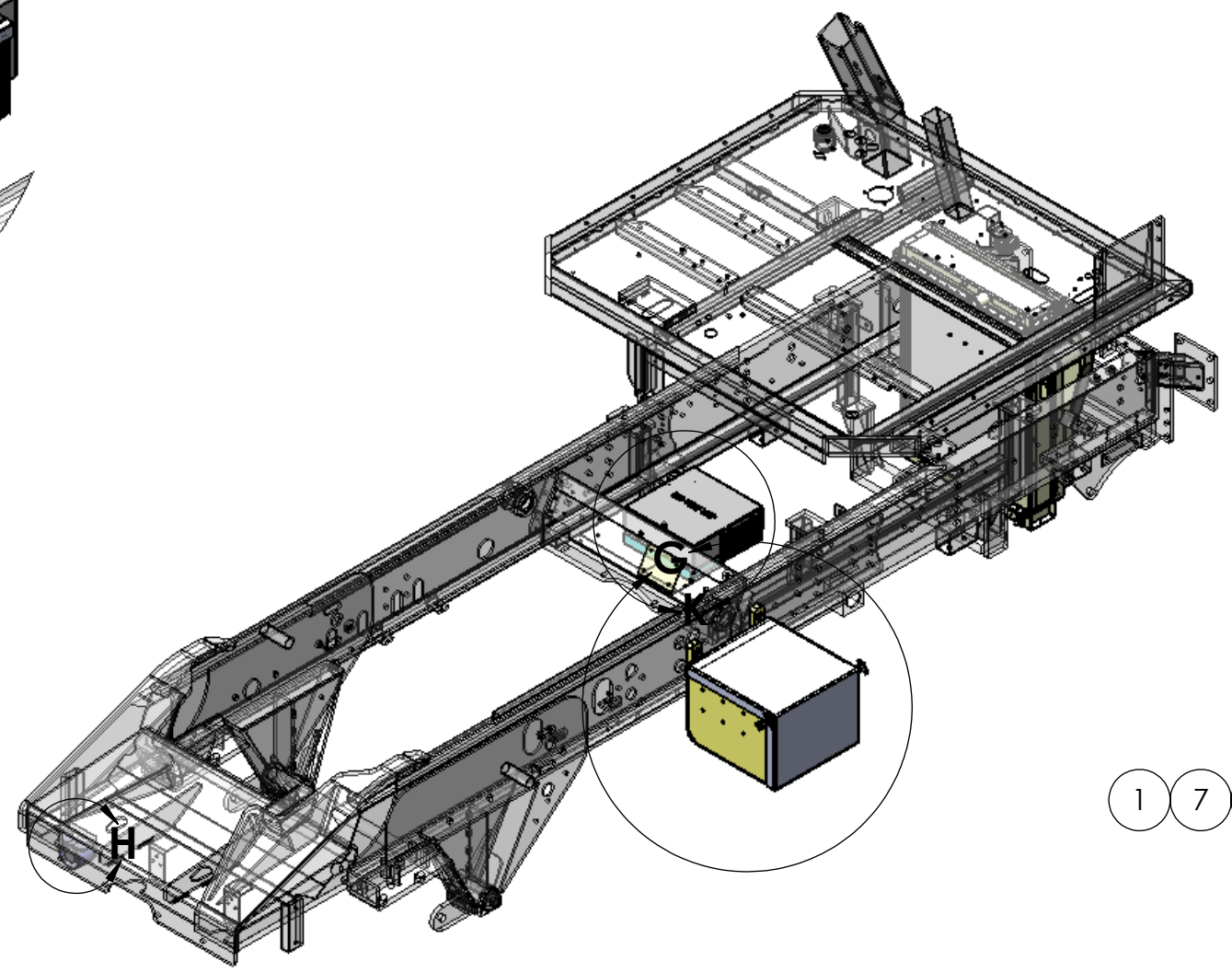

1 7 8 9 10
2X

**BATTERY BOX
PAGE 2**

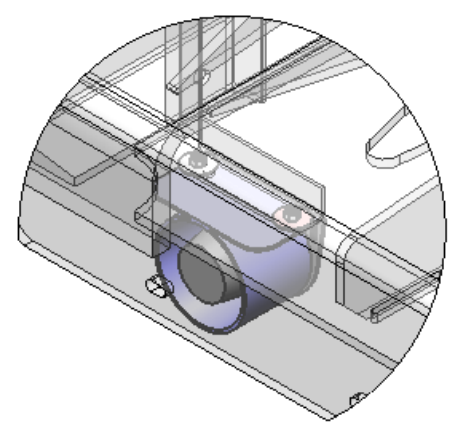



**BACKUP ALARM
PAGE 2**

DIMENSIONS ARE IN INCHES		NAME	DATE	 TICO/TERMINAL SERVICE 66 CYPRESS RIDGE DR. RIDGELAND, SC 29936 (843) 717-2226	
TOLERANCES:		DRAWN	MPC		4/21/2017
DECIMAL:		CHECKED			
X.X ± 0.06 X.XX ± 0.03 X.XXX ± 0.005		APPROVED			
ANGULAR: ± 0.5°		DO NOT SCALE DRAWING			
FRACTIONAL: ± 1/32"		THE SUBJECT MATTER SHOWN AND DESCRIBED IN THIS DRAWING AND ANY OTHER INFORMATION ADVANCED IN CONNECTION THEREWITH, IS PROPRIETARY PROPERTY AND IS TO BE HELD IN STRICT CONFIDENCE BY YOU. ALL RIGHTS TO ANY INVENTIONS, DESIGNS, TRADE MARKS, TRADE NAMES AND COPYRIGHTS DISCLOSED ARE RESERVED TO TICO TERMINAL SERVICES, INC.			
INTERPRET GEOMETRIC TOLERANCING PER: ASME 14.5M-1994		TITLE:		ASSEMBLY, BATTERY & WIRING	
MATERIAL		SIZE	DWG. NO.	REV	
FINISH		B	721046-A1		
THICKNESS		SCALE: 1:48	WEIGHT:	SHEET 1 OF 3	

8 7 6 5 4 3 2 1

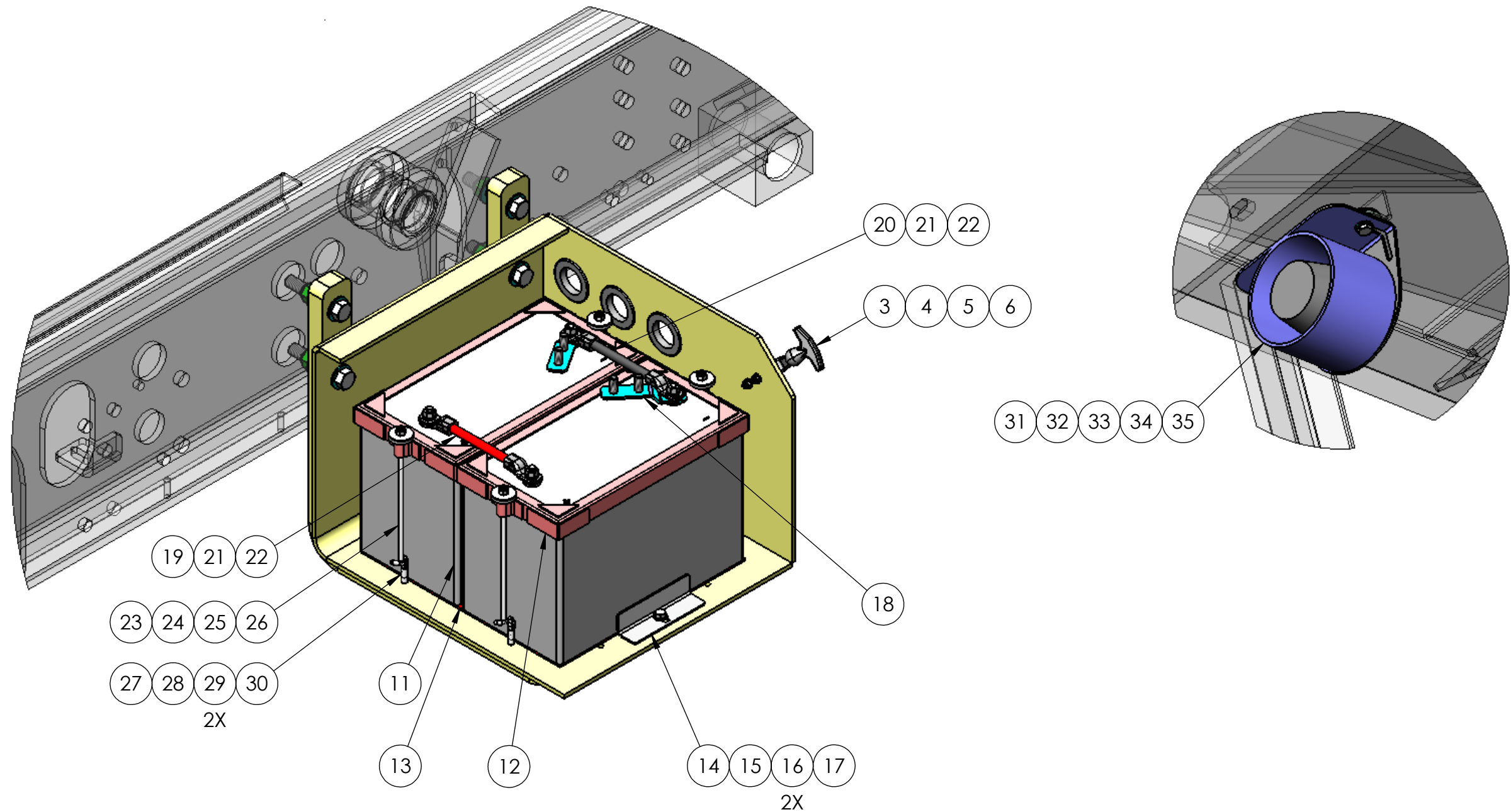
D
C
B
A



DIMENSIONS ARE IN INCHES		NAME	DATE	 TICO/TERMINAL SERVICE 66 CYPRESS RIDGE DR. RIDGELAND, SC 29936 (843) 717-2226	
TOLERANCES:		DRAWN	MPC		4/21/2017
DECIMAL:		CHECKED			
X.X ± 0.06 X.XX ± 0.03 X.XXX ± 0.005		APPROVED			
ANGULAR: ± 0.5°		DO NOT SCALE DRAWING			
FRACTIONAL: ± 1/32"		INTERPRET GEOMETRIC TOLERANCING PER: ASME 14.5M-1994			
MATERIAL		THE SUBJECT MATTER SHOWN AND DESCRIBED IN THIS DRAWING AND ANY OTHER INFORMATION ADVANCED IN CONNECTION THEREWITH, IS PROPRIETARY PROPERTY AND IS TO BE HELD IN STRICT CONFIDENCE BY YOU. ALL RIGHTS TO ANY INVENTIONS, DESIGNS, TRADE MARKS, TRADE NAMES AND COPYRIGHTS DISCLOSED ARE RESERVED TO TICO TERMINAL SERVICES, INC.			
FINISH		SIZE	DWG. NO.	REV	
THICKNESS		B	721046-A1		
		SCALE: 1:48	WEIGHT:	SHEET 2 OF 3	

8 7 6 5 4 3 2 1

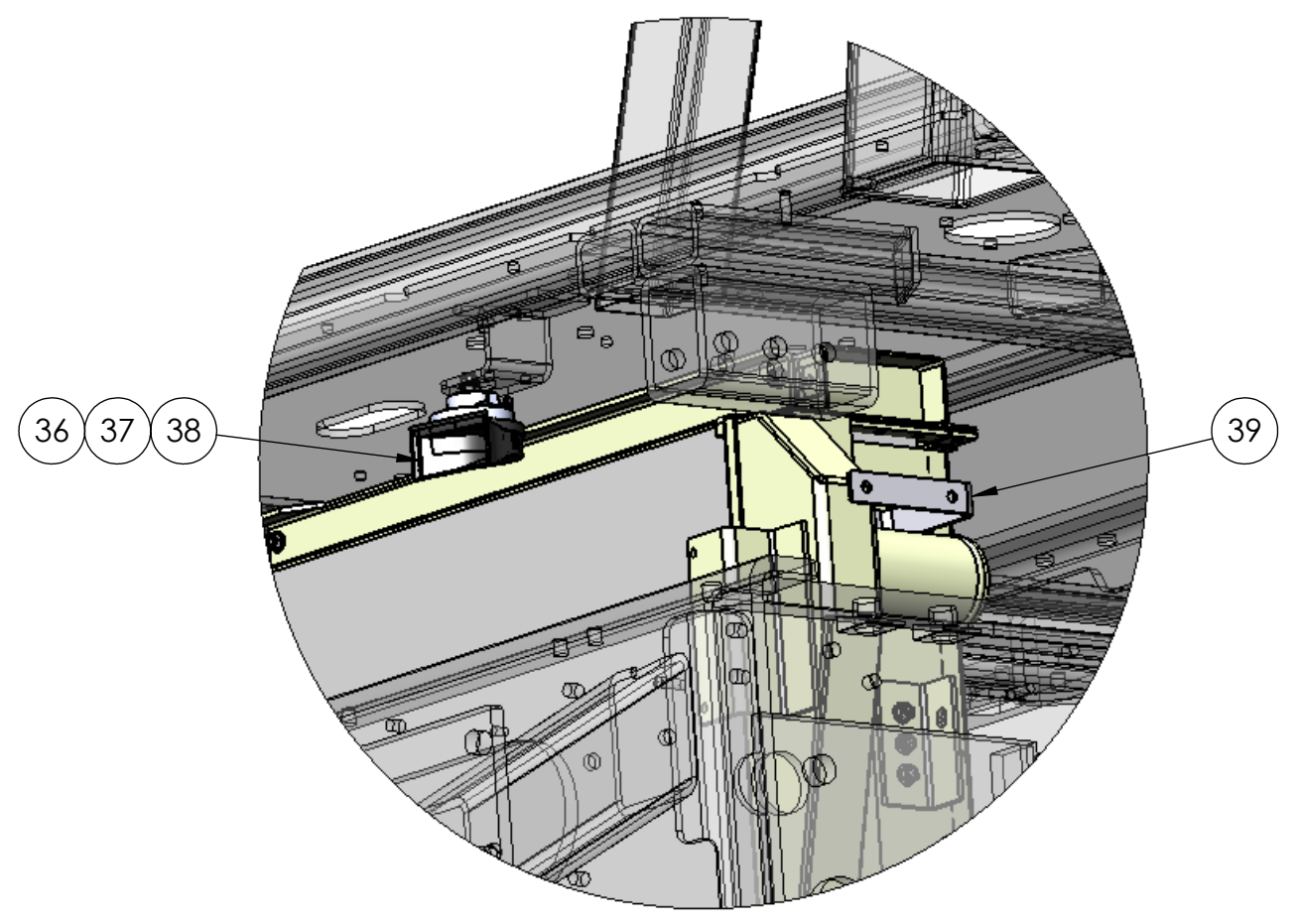
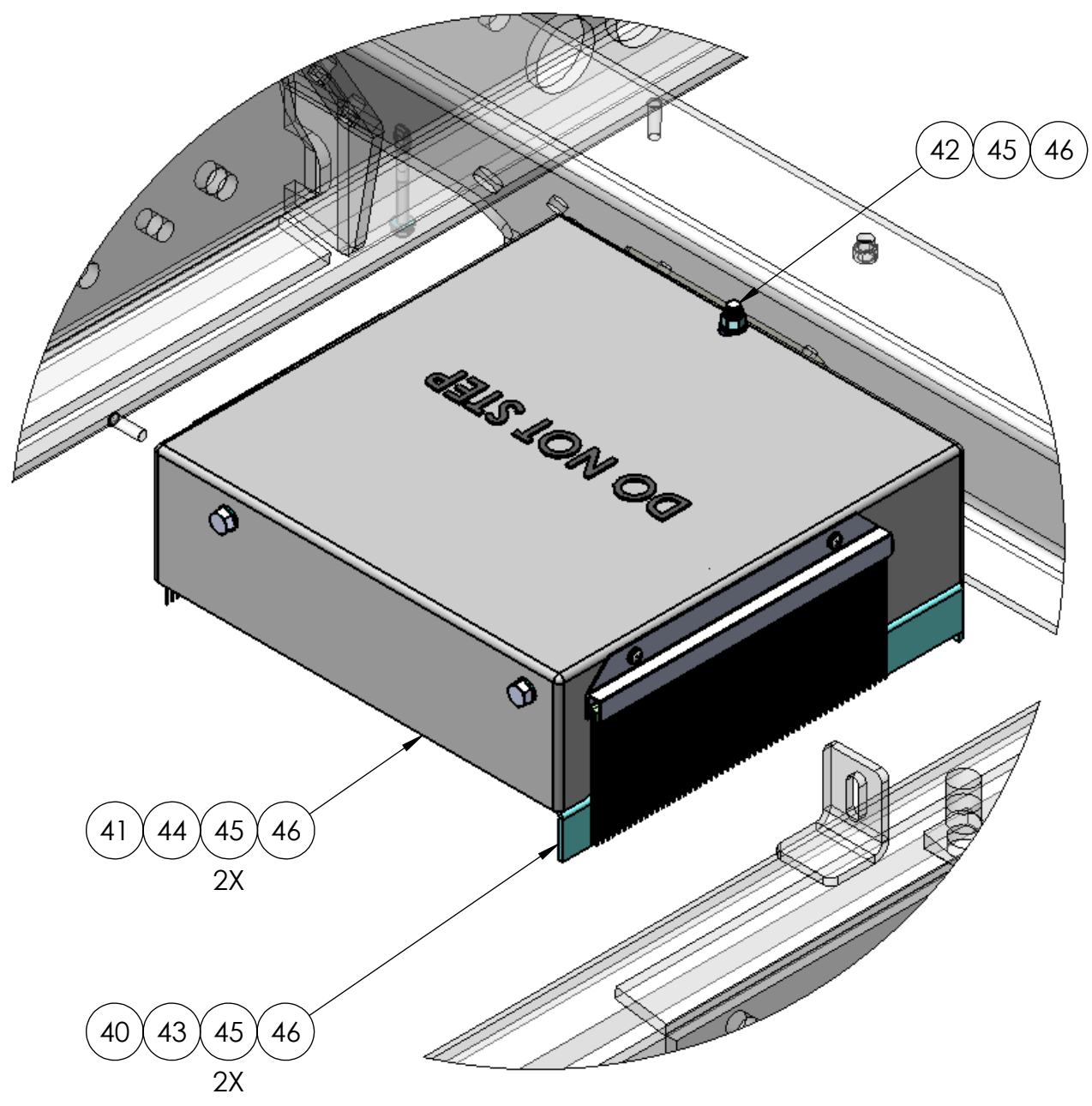

DIMENSIONS ARE IN INCHES		NAME	DATE	 TICO/TERMINAL SERVICE 66 CYPRESS RIDGE DR. RIDGELAND, SC 29936 (843) 717-2226
TOLERANCES:		DRAWN	MPC 4/21/2017	
DECIMAL:		CHECKED		
X.X ± 0.06 X.XX ± 0.03 X.XXX ± 0.005		APPROVED		
ANGULAR: ± 0.5°		DO NOT SCALE DRAWING		
FRACTIONAL ± 1/32"		TITLE: ASSEMBLY, BATTERY & WIRING		
INTERPRET GEOMETRIC TOLERANCING PER: ASME 14.5M-1994		SIZE B		DWG. NO. 721046-A1
MATERIAL		REV		
FINISH		SCALE: 1:48		WEIGHT:
THICKNESS		SHEET 3 OF 3		

