

| | | | | |
|--------------------------|----------|---|-----------|--|
| DIMENSIONS ARE IN INCHES | | NAME | DATE | TICO MANUFACTURING 44 CYPRESS RIDGE DR. RICHLAND, SC 29726 (843) 717-2226 |
| TOLERANCES: | | DRAWN | ADW | |
| DECIMAL | .0005 | BY | 8/104 | CHECKED |
| FRACTIONAL | 1/16" | XXX | 8/103 | |
| ANGULAR | ± 0.1° | XXX | 8/103 | APPROVED |
| FRACTIONAL | ± 1/32" | XXX | 8/103 | |
| DO NOT SCALE DRAWING | | THE SUBJECT MATTER SHOWN AND DESCRIBED IN THIS DRAWING AND ANY OTHER REPRESENTATION DERIVED FROM CONNECTION INFORMATION IS TO BE USED ONLY FOR THE PURPOSES OF THIS DRAWING. NO WARRANTIES, EXPRESS OR IMPLIED, ARE MADE BY TICO MANUFACTURING FOR THE ACCURACY OF THIS DRAWING. ALL RIGHTS TO ANY PATENTS, TRADE MARKS, AND COPYRIGHTS NOTICED ARE RESERVED BY TICO MANUFACTURING. | | |
| DATE | N/A | SIZE | DWG. NO. | REV |
| ISSUE | SEE NOTE | D | 720955-A1 | |
| REVISION | N/A | SCALE | 1:4 | WEIGHT: 19.69 |
| | | | | SHEET 1 OF 1 |

720955-A1

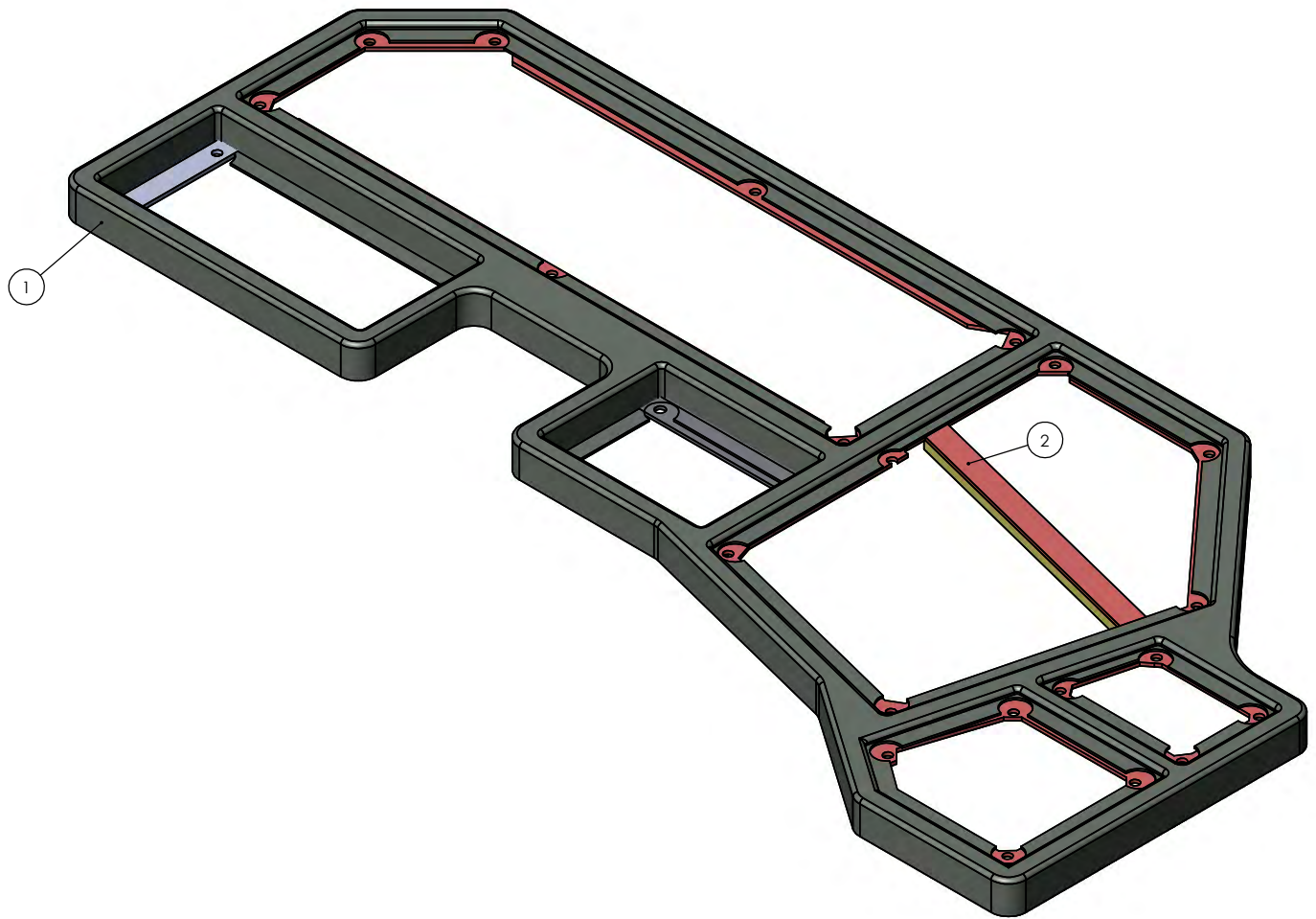

| | | | | | |
|--|--------|---|--------------|--------------------|----------------------|
| DIMENSIONS ARE IN INCHES | | NAME | DATE | TICO MANUFACTURING | |
| TOLERANCES: | | DRAWN | ADW | 06/22/2020 | 66 CYPRESS RIDGE DR. |
| DECIMAL | .005 | CHECKED | | | ROCKLAND, NC 29154 |
| FRACTIONAL | 1/32 | APPROVED | | | TICORACTORS.COM |
| ANGULAR | ± 0.1° | DO NOT SCALE DRAWING | | | |
| INSURE GEOMETRIC TOLERANCING PER ASME Y14.5M | | THE SUBJECT MATTER SHOWN AND DESCRIBED IN THIS DRAWING AND ANY OTHER INFORMATION CONTAINED IN CONNECTION HEREWITH IS TO BE REPRODUCED IN WHOLE OR IN PART WITHOUT THE WRITTEN CONSENT OF TICO MANUFACTURING AND CONFORMS TO THE DIMENSIONS AND CONSTRUCTION SPECIFICATIONS THEREON. | | | |
| DATE | | SIZE | DWG. NO. | REV | |
| DRAWN | | D | 91646-A1 ILL | | |
| CHECKED | | SCALE: 1:4 | WEIGHT: 7.29 | SHEET 1 OF 1 | |

D 91646-A1 ILL

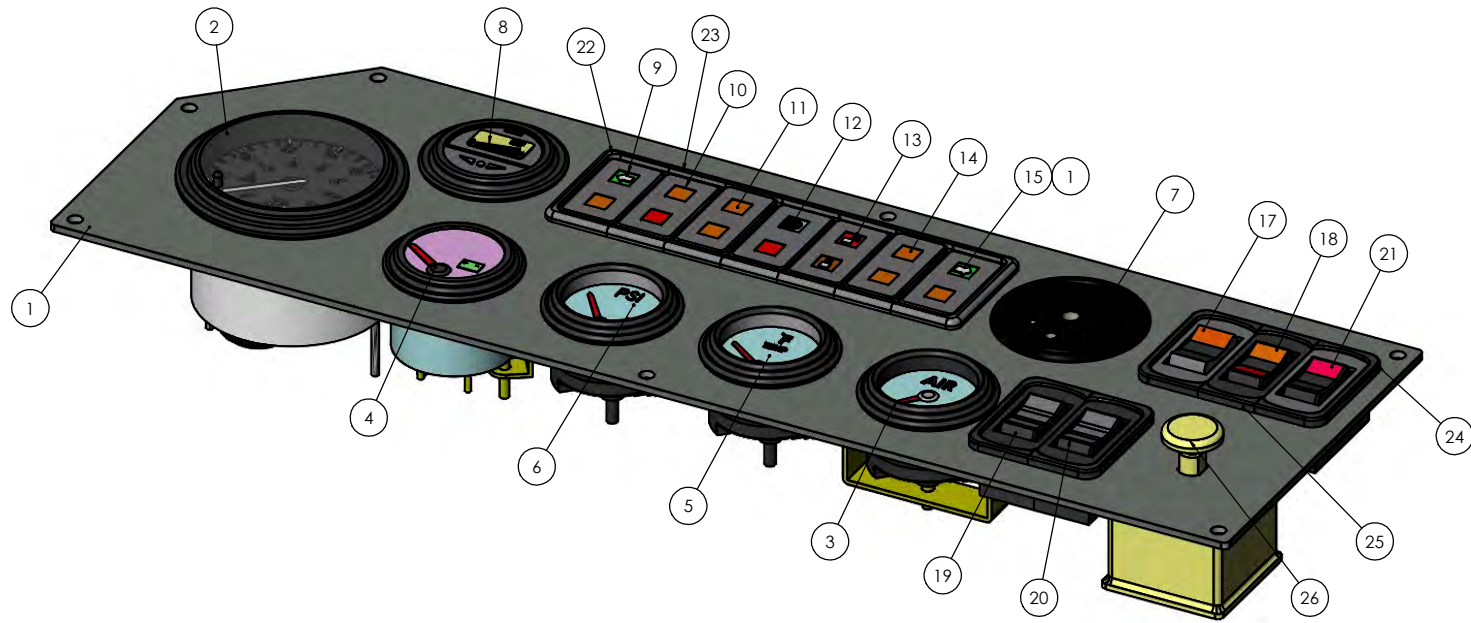

| | | | | |
|------------------------------|--------|----------------------|------|----------------------|
| DIMENSIONS ARE IN INCHES | | NAME | DATE | TICO MANUFACTURING |
| TOLERANCES: | | DRAWN | AGW | 04/22/2020 |
| DECIMAL | ± .005 | CHECKED | | 44 CYPRESS RIDGE DR. |
| FRACTIONAL | ± .005 | APPROVED | | ROCKLAND, SC 29574 |
| ANGULAR | ± .1° | DO NOT SCALE DRAWING | | TICORACTORS.COM |
| FUNCTIONAL | ± .005 | | | |
| INSURE GEOMETRIC TOLERANCING | | | | |
| PER ASME Y14.5M | | | | |
| DATA | | | | |
| DATE | | | | |
| REV | | | | |
| SEE NOTE | | | | |
| REVISION | | | | |
| | | | | |

TICO
 TITLE: ASSY PANEL DASH GAUGE - 2013-18 MPH SPEEDO INT WIPER
 SIZE DWG. NO. 20266-A1 ILL REV
 SCALE: 1:2 WEIGHT: 2.23 SHEET 1 OF 1

D 20266-A1 ILL

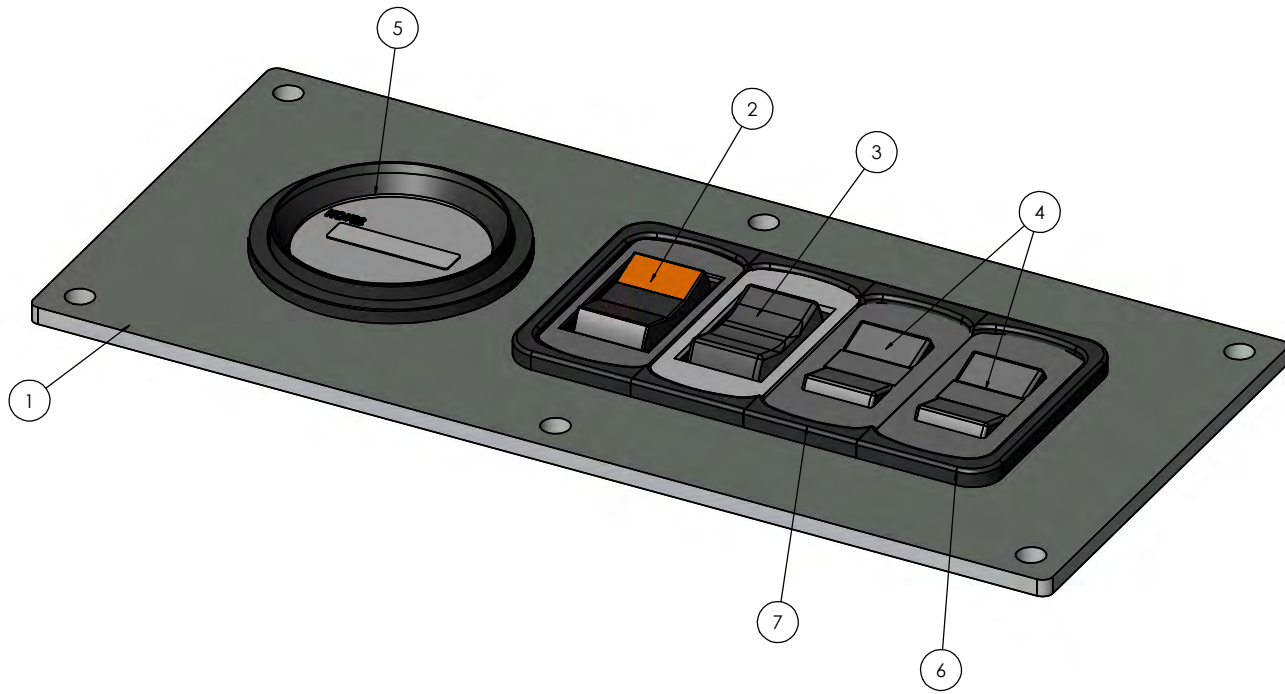

| | | | | |
|--|--------------|------------------------------|------|----------------------|
| DIMENSIONS ARE IN INCHES | | NAME | DATE | TICO MANUFACTURING |
| TOLERANCES: | | DRAWN | ADW | 04/09/2020 |
| DECIMAL | ± .005 | CHECKED | | 44 CYPRESS RIDGE DR. |
| XXX ± .010 | | APPROVED | | ROCKLAND, SC 29554 |
| XXX ± .020 | | | | TICORACTORS.COM |
| FRACTIONAL | ± .010 | DO NOT SCALE DRAWING | | |
| ANGULAR | ± 0.1° | THE SUBJECT MATTER SHOWN AND | | |
| UNLESS OTHERWISE SPECIFIED, ALL DIMENSIONS ARE TO BE | | | | |
| TOLERANCES UNLESS OTHERWISE SPECIFIED. | | | | |
| ALL RIGHTS TO ANY PATENTS, TRADE | | | | |
| MARKS, AND OTHER INTELLECTUAL | | | | |
| PROPERTY ARE RESERVED BY TICO MANUFACTURING, INC. | | | | |
| TITLE | | ASSY PANEL | | |
| HOURMETER/DIAGNOSTIC - | | ISB | | |
| SIZE | DWG. NO. | REV | | |
| D | 91780-A1 | | | |
| SCALE: 1:1 | WEIGHT: 0.48 | SHEET 1 OF 1 | | |

91780-A1

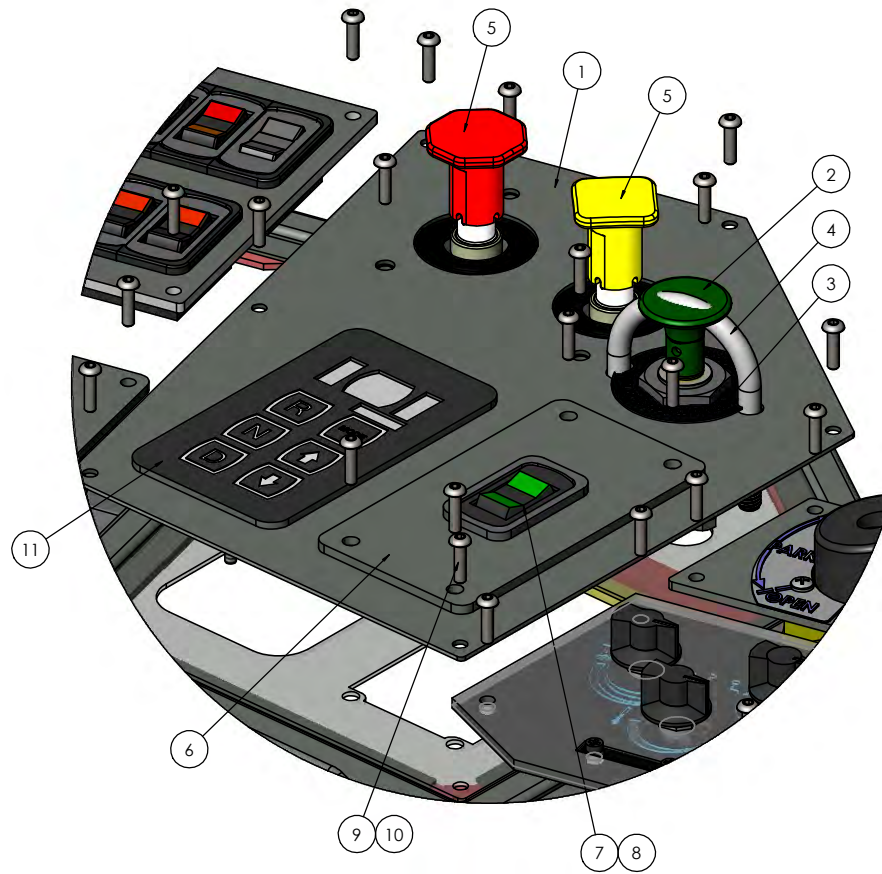

| | | | | |
|--------------------------|---------|----------|------|----------------------|
| DIMENSIONS ARE IN INCHES | | NAME | DATE | TICO MANUFACTURING |
| TOLERANCES: | DECIMAL | DRAWN | ADW | 6/16/2020 |
| | .0005 | CHECKED | | 66 CYPRESS RIDGE DR. |
| | .001 | APPROVED | | ROCKLAND, SC 29574 |
| | .002 | | | TICORACTORS.COM |
| | .005 | | | |
| | .010 | | | |
| | .015 | | | |
| | .020 | | | |
| | .030 | | | |
| | .040 | | | |
| | .050 | | | |
| | .060 | | | |
| | .070 | | | |
| | .080 | | | |
| | .090 | | | |
| | .100 | | | |
| | .125 | | | |
| | .150 | | | |
| | .175 | | | |
| | .200 | | | |
| | .250 | | | |
| | .300 | | | |
| | .375 | | | |
| | .450 | | | |
| | .500 | | | |
| | .625 | | | |
| | .750 | | | |
| | .875 | | | |
| | 1.000 | | | |
| | 1.250 | | | |
| | 1.500 | | | |
| | 1.750 | | | |
| | 2.000 | | | |
| | 2.500 | | | |
| | 3.000 | | | |
| | 3.500 | | | |
| | 4.000 | | | |
| | 4.500 | | | |
| | 5.000 | | | |
| | 5.500 | | | |
| | 6.000 | | | |
| | 6.500 | | | |
| | 7.000 | | | |
| | 7.500 | | | |
| | 8.000 | | | |
| | 8.500 | | | |
| | 9.000 | | | |
| | 9.500 | | | |
| | 10.000 | | | |
| | 10.500 | | | |
| | 11.000 | | | |
| | 11.500 | | | |
| | 12.000 | | | |
| | 12.500 | | | |
| | 13.000 | | | |
| | 13.500 | | | |
| | 14.000 | | | |
| | 14.500 | | | |
| | 15.000 | | | |
| | 15.500 | | | |
| | 16.000 | | | |
| | 16.500 | | | |
| | 17.000 | | | |
| | 17.500 | | | |
| | 18.000 | | | |
| | 18.500 | | | |
| | 19.000 | | | |
| | 19.500 | | | |
| | 20.000 | | | |
| | 20.500 | | | |
| | 21.000 | | | |
| | 21.500 | | | |
| | 22.000 | | | |
| | 22.500 | | | |
| | 23.000 | | | |
| | 23.500 | | | |
| | 24.000 | | | |
| | 24.500 | | | |
| | 25.000 | | | |
| | 25.500 | | | |
| | 26.000 | | | |
| | 26.500 | | | |
| | 27.000 | | | |
| | 27.500 | | | |
| | 28.000 | | | |
| | 28.500 | | | |
| | 29.000 | | | |
| | 29.500 | | | |
| | 30.000 | | | |
| | 30.500 | | | |
| | 31.000 | | | |
| | 31.500 | | | |
| | 32.000 | | | |
| | 32.500 | | | |
| | 33.000 | | | |
| | 33.500 | | | |
| | 34.000 | | | |
| | 34.500 | | | |
| | 35.000 | | | |
| | 35.500 | | | |
| | 36.000 | | | |
| | 36.500 | | | |
| | 37.000 | | | |
| | 37.500 | | | |
| | 38.000 | | | |
| | 38.500 | | | |
| | 39.000 | | | |
| | 39.500 | | | |
| | 40.000 | | | |
| | 40.500 | | | |
| | 41.000 | | | |
| | 41.500 | | | |
| | 42.000 | | | |
| | 42.500 | | | |
| | 43.000 | | | |
| | 43.500 | | | |
| | 44.000 | | | |
| | 44.500 | | | |
| | 45.000 | | | |
| | 45.500 | | | |
| | 46.000 | | | |
| | 46.500 | | | |
| | 47.000 | | | |
| | 47.500 | | | |
| | 48.000 | | | |
| | 48.500 | | | |
| | 49.000 | | | |
| | 49.500 | | | |
| | 50.000 | | | |
| | 50.500 | | | |
| | 51.000 | | | |
| | 51.500 | | | |
| | 52.000 | | | |
| | 52.500 | | | |
| | 53.000 | | | |
| | 53.500 | | | |
| | 54.000 | | | |
| | 54.500 | | | |
| | 55.000 | | | |
| | 55.500 | | | |
| | 56.000 | | | |
| | 56.500 | | | |
| | 57.000 | | | |
| | 57.500 | | | |
| | 58.000 | | | |
| | 58.500 | | | |
| | 59.000 | | | |
| | 59.500 | | | |
| | 60.000 | | | |
| | 60.500 | | | |
| | 61.000 | | | |
| | 61.500 | | | |
| | 62.000 | | | |
| | 62.500 | | | |
| | 63.000 | | | |
| | 63.500 | | | |
| | 64.000 | | | |
| | 64.500 | | | |
| | 65.000 | | | |
| | 65.500 | | | |
| | 66.000 | | | |
| | 66.500 | | | |
| | 67.000 | | | |
| | 67.500 | | | |
| | 68.000 | | | |
| | 68.500 | | | |
| | 69.000 | | | |
| | 69.500 | | | |
| | 70.000 | | | |
| | 70.500 | | | |
| | 71.000 | | | |
| | 71.500 | | | |
| | 72.000 | | | |
| | 72.500 | | | |
| | 73.000 | | | |
| | 73.500 | | | |
| | 74.000 | | | |
| | 74.500 | | | |
| | 75.000 | | | |
| | 75.500 | | | |
| | 76.000 | | | |
| | 76.500 | | | |
| | 77.000 | | | |
| | 77.500 | | | |
| | 78.000 | | | |
| | 78.500 | | | |
| | 79.000 | | | |
| | 79.500 | | | |
| | 80.000 | | | |
| | 80.500 | | | |
| | 81.000 | | | |
| | 81.500 | | | |
| | 82.000 | | | |
| | 82.500 | | | |
| | 83.000 | | | |
| | 83.500 | | | |
| | 84.000 | | | |
| | 84.500 | | | |
| | 85.000 | | | |
| | 85.500 | | | |
| | 86.000 | | | |
| | 86.500 | | | |
| | 87.000 | | | |
| | 87.500 | | | |
| | 88.000 | | | |
| | 88.500 | | | |
| | 89.000 | | | |
| | 89.500 | | | |
| | 90.000 | | | |
| | 90.500 | | | |
| | 91.000 | | | |
| | 91.500 | | | |
| | 92.000 | | | |
| | 92.500 | | | |
| | 93.000 | | | |
| | 93.500 | | | |
| | 94.000 | | | |
| | 94.500 | | | |
| | 95.000 | | | |
| | 95.500 | | | |
| | 96.000 | | | |
| | 96.500 | | | |
| | 97.000 | | | |
| | 97.500 | | | |
| | 98.000 | | | |
| | 98.500 | | | |
| | 99.000 | | | |
| | 99.500 | | | |
| | 100.000 | | | |

TICO MANUFACTURING
 66 CYPRESS RIDGE DR.
 ROCKLAND, SC 29574
 TICORACTORS.COM
 TITLE: DASH PANEL-PB
 SHIFTER/HEATER/MV3/ELEC
 SIZE DWG. NO. 20116-A1 ILL REV
 SCALE: 1:4 WEIGHT: 18.03 SHEET 1 OF 1

20116-A1 ILL 001



| | | | | | |
|---|---------|--|------|--------------------------------|--------------|
| DIMENSIONS ARE IN INCHES | | NAME | DATE | TICO MANUFACTURING | |
| TOLERANCES: | | DRAWN | ADW | 04/22/2020 | |
| DECIMAL | .005 | CHECKED | | 44 CYPRESS RIDGE DR. | |
| FRACTIONAL | 1/32 | APPROVED | | ROCKLAND, NC 27854 | |
| ANGULAR | ± 0.1° | | | TICORACTORS.COM | |
| FUNCTIONAL | ± 0.005 | | | | |
| INSURE GEOMETRIC TOLERANCING PER ASME Y14.5M | | DO NOT SCALE DRAWING | | TITLE: HEATER CONTROL ASSEMBLY | |
| UNLESS OTHERWISE SPECIFIED, ALL DIMENSIONS ARE TO BE TAKEN FROM THE DIMENSIONED SURFACE UNLESS OTHERWISE SPECIFIED. | | THE SUBJECT MATTER SHOWN AND DESCRIBED IN THIS DRAWING AND ANY OTHER INFORMATION CONTAINED HEREIN IS THE PROPERTY OF TICO MANUFACTURING, INC. AND IS TO BE KEPT IN CONFIDENCE BY ALL PARTS TO WHOM IT IS FURNISHED. NO PARTS, INFORMATION, DRAWINGS, OR CONCEPTS DISCLOSED ARE TO BE REPRODUCED OR USED FOR ANY OTHER PURPOSE WITHOUT THE WRITTEN PERMISSION OF TICO MANUFACTURING, INC. | | SIZE DWG. NO. | REV |
| MATERIAL NOT SPECIFIED | | SCALE: 1:1 | | WEIGHT: 0.27 | SHEET 1 OF 1 |
| REVISIONS: | | | | | |

D 20900-A1 ILL

