

DIMENSIONS ARE IN INCHES		NAME	DATE	TICO MANUFACTURING 44 CYPRESS RIDGE DR. ROSELAND, NC 27068 (843) 717-2226	
TOLERANCES:		DRAWN	ADW		06/03/2020
DECIMAL	.005	BY	8/18		
ANGULAR	± 0.1°	CHECKED			
FRACTIONAL	± 0.005	APPROVED		TITLE: DASH ASSY - QSB-RDS, KPH - 12V-PUSH BUTTN- KEY DO NOT SCALE DRAWING THE SUBJECT MATTER SHOWN AND DESCRIBED IN THIS DRAWING AND ANY OTHER REPRESENTATION, INCLUDING CONNECTIONS, DIMENSIONS, & SPECIFICATIONS, MUST BE USED TO BE FULLY CONFORMANT WITH ALL RIGHTS TO ANY PATENTS, TRADE MARKS, OR COPYRIGHTS, WHICH HAVE BEEN OR WILL BE ASSIGNED TO TICO MANUFACTURING, INC.	
DATE	N/A	SIZE	DWG. NO.		REV
ISSUE	SEE NOTE	SCALE	1:4	720880-A1	
REVISION	N/A	WEIGHT	19.69	SHEET	1 OF 1

720880-A1

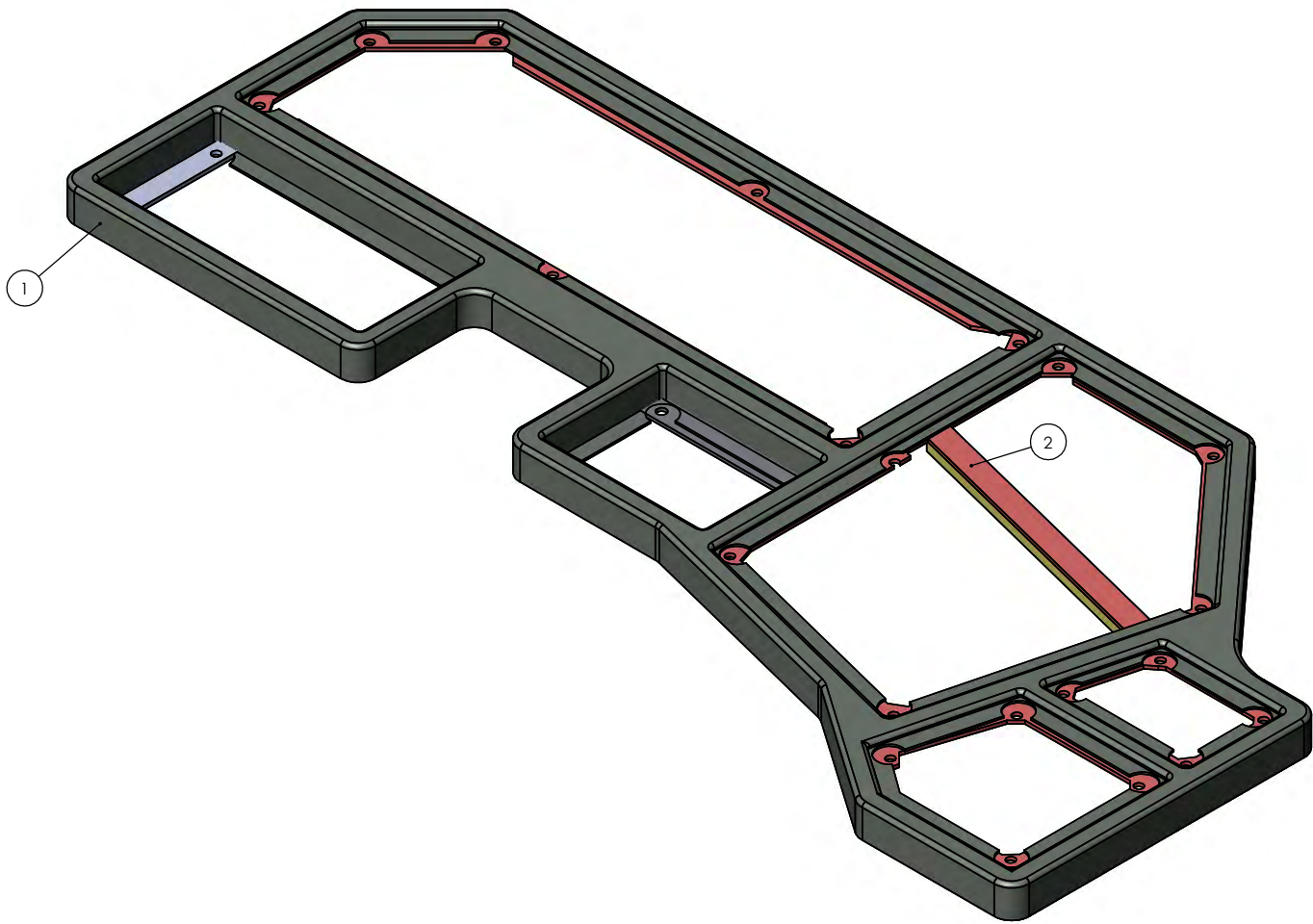

DIMENSIONS ARE IN INCHES		NAME	DATE	TICO MANUFACTURING	
TOLERANCES:		DRAWN	ADW	06/22/2020	44 CYPRESS RIDGE DR.
DECIMAL	.XX	CHECKED			ROCKLAND, NC 29154
	.XXX	APPROVED			TICORACTORS.COM
	.XXX & UP				
FRACTIONAL	1/16	DO NOT SCALE DRAWING			
	1/32	THE SUBJECT MATTER SHOWN AND			
	1/64	DESCRIBED IN THIS DRAWING AND ANY			
	3/32	OTHER REFERENCE IS INDICATED IN			
	1/2	CONNECTIONS BETWEEN PARTS TO BE			
	1	MATED TO THE DIMENSIONS OF THE			
	2	PARTS TO WHICH THEY ARE TO BE			
	3	MATED AND CONFORMS TO THE			
	4	DRAWING AND CONFORMS TO THE			
	5	DIMENSIONS AND CONFORMS TO THE			
	6	DIMENSIONS AND CONFORMS TO THE			
	7	DIMENSIONS AND CONFORMS TO THE			
	8	DIMENSIONS AND CONFORMS TO THE			
	9	DIMENSIONS AND CONFORMS TO THE			
	10	DIMENSIONS AND CONFORMS TO THE			
	11	DIMENSIONS AND CONFORMS TO THE			
	12	DIMENSIONS AND CONFORMS TO THE			
	13	DIMENSIONS AND CONFORMS TO THE			
	14	DIMENSIONS AND CONFORMS TO THE			
	15	DIMENSIONS AND CONFORMS TO THE			
	16	DIMENSIONS AND CONFORMS TO THE			
	17	DIMENSIONS AND CONFORMS TO THE			
	18	DIMENSIONS AND CONFORMS TO THE			
	19	DIMENSIONS AND CONFORMS TO THE			
	20	DIMENSIONS AND CONFORMS TO THE			
	21	DIMENSIONS AND CONFORMS TO THE			
	22	DIMENSIONS AND CONFORMS TO THE			
	23	DIMENSIONS AND CONFORMS TO THE			
	24	DIMENSIONS AND CONFORMS TO THE			
	25	DIMENSIONS AND CONFORMS TO THE			
	26	DIMENSIONS AND CONFORMS TO THE			
	27	DIMENSIONS AND CONFORMS TO THE			
	28	DIMENSIONS AND CONFORMS TO THE			
	29	DIMENSIONS AND CONFORMS TO THE			
	30	DIMENSIONS AND CONFORMS TO THE			
	31	DIMENSIONS AND CONFORMS TO THE			
	32	DIMENSIONS AND CONFORMS TO THE			
	33	DIMENSIONS AND CONFORMS TO THE			
	34	DIMENSIONS AND CONFORMS TO THE			
	35	DIMENSIONS AND CONFORMS TO THE			
	36	DIMENSIONS AND CONFORMS TO THE			
	37	DIMENSIONS AND CONFORMS TO THE			
	38	DIMENSIONS AND CONFORMS TO THE			
	39	DIMENSIONS AND CONFORMS TO THE			
	40	DIMENSIONS AND CONFORMS TO THE			
	41	DIMENSIONS AND CONFORMS TO THE			
	42	DIMENSIONS AND CONFORMS TO THE			
	43	DIMENSIONS AND CONFORMS TO THE			
	44	DIMENSIONS AND CONFORMS TO THE			
	45	DIMENSIONS AND CONFORMS TO THE			
	46	DIMENSIONS AND CONFORMS TO THE			
	47	DIMENSIONS AND CONFORMS TO THE			
	48	DIMENSIONS AND CONFORMS TO THE			
	49	DIMENSIONS AND CONFORMS TO THE			
	50	DIMENSIONS AND CONFORMS TO THE			
	51	DIMENSIONS AND CONFORMS TO THE			
	52	DIMENSIONS AND CONFORMS TO THE			
	53	DIMENSIONS AND CONFORMS TO THE			
	54	DIMENSIONS AND CONFORMS TO THE			
	55	DIMENSIONS AND CONFORMS TO THE			
	56	DIMENSIONS AND CONFORMS TO THE			
	57	DIMENSIONS AND CONFORMS TO THE			
	58	DIMENSIONS AND CONFORMS TO THE			
	59	DIMENSIONS AND CONFORMS TO THE			
	60	DIMENSIONS AND CONFORMS TO THE			
	61	DIMENSIONS AND CONFORMS TO THE			
	62	DIMENSIONS AND CONFORMS TO THE			
	63	DIMENSIONS AND CONFORMS TO THE			
	64	DIMENSIONS AND CONFORMS TO THE			
	65	DIMENSIONS AND CONFORMS TO THE			
	66	DIMENSIONS AND CONFORMS TO THE			
	67	DIMENSIONS AND CONFORMS TO THE			
	68	DIMENSIONS AND CONFORMS TO THE			
	69	DIMENSIONS AND CONFORMS TO THE			
	70	DIMENSIONS AND CONFORMS TO THE			
	71	DIMENSIONS AND CONFORMS TO THE			
	72	DIMENSIONS AND CONFORMS TO THE			
	73	DIMENSIONS AND CONFORMS TO THE			
	74	DIMENSIONS AND CONFORMS TO THE			
	75	DIMENSIONS AND CONFORMS TO THE			
	76	DIMENSIONS AND CONFORMS TO THE			
	77	DIMENSIONS AND CONFORMS TO THE			
	78	DIMENSIONS AND CONFORMS TO THE			
	79	DIMENSIONS AND CONFORMS TO THE			
	80	DIMENSIONS AND CONFORMS TO THE			
	81	DIMENSIONS AND CONFORMS TO THE			
	82	DIMENSIONS AND CONFORMS TO THE			
	83	DIMENSIONS AND CONFORMS TO THE			
	84	DIMENSIONS AND CONFORMS TO THE			
	85	DIMENSIONS AND CONFORMS TO THE			
	86	DIMENSIONS AND CONFORMS TO THE			
	87	DIMENSIONS AND CONFORMS TO THE			
	88	DIMENSIONS AND CONFORMS TO THE			
	89	DIMENSIONS AND CONFORMS TO THE			
	90	DIMENSIONS AND CONFORMS TO THE			
	91	DIMENSIONS AND CONFORMS TO THE			
	92	DIMENSIONS AND CONFORMS TO THE			
	93	DIMENSIONS AND CONFORMS TO THE			
	94	DIMENSIONS AND CONFORMS TO THE			
	95	DIMENSIONS AND CONFORMS TO THE			
	96	DIMENSIONS AND CONFORMS TO THE			
	97	DIMENSIONS AND CONFORMS TO THE			
	98	DIMENSIONS AND CONFORMS TO THE			
	99	DIMENSIONS AND CONFORMS TO THE			
	100	DIMENSIONS AND CONFORMS TO THE			

TICO
 TITLE: DASH COVER ASSEMBLY ISB
 10
 SIZE DWG. NO. 91646-A1
 SCALE: 1:4 | WEIGHT: 7.29 | SHEET 1 OF 1

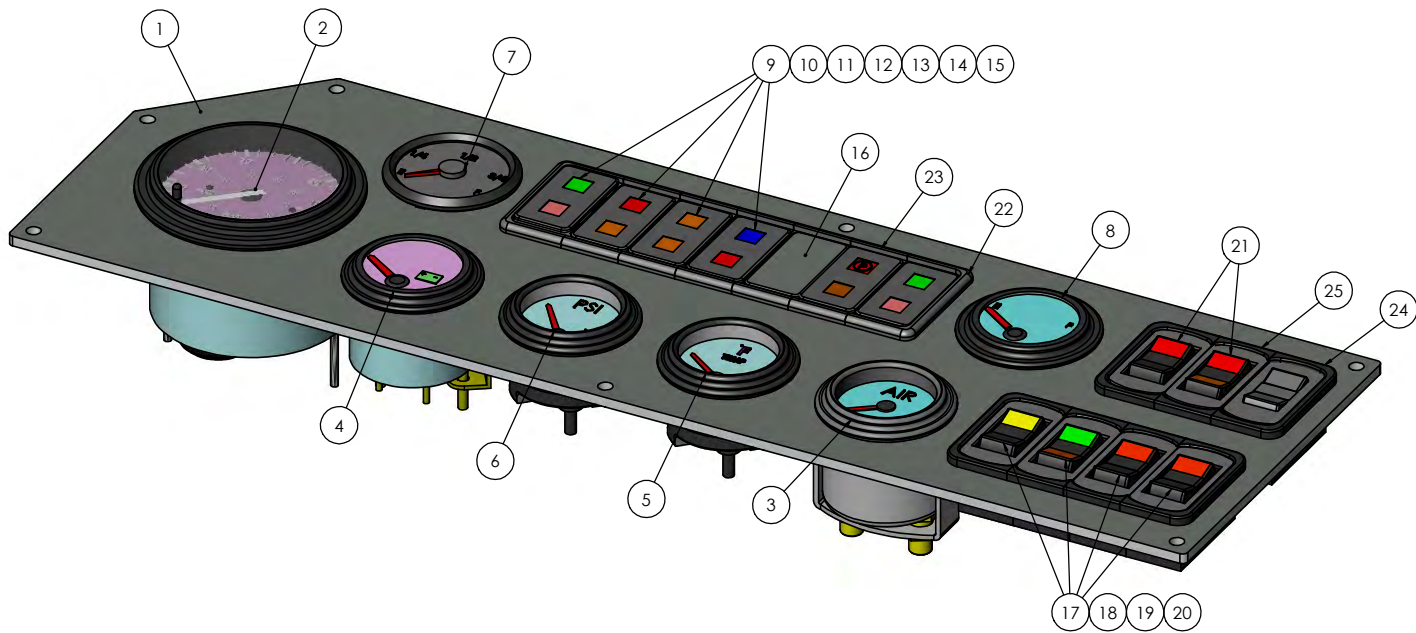

DIMENSIONS ARE IN INCHES		NAME	DATE	TICO MANUFACTURING
TOLERANCES:		DRAWN	ADW	04/22/2020
DECIMAL	.0005	CHECKED		44 CYPRESS RIDGE DR.
FRACTIONAL	1/16	APPROVED		ROCKLAND, NC 28154
ANGULAR	±0.1°			TICORACTORS.COM
FUNCTIONAL	±0.002			
INSPECTOR OF CONTRACT COORDINATING		DO NOT SCALE DRAWING		
FOR NAME & DRAWING		THE SUBJECT MATTER SHOWN AND		
		DESCRIBED IN THIS DRAWING AND ANY		
		OTHER REFERENCE TO, ADVANCED BY		
		CONTRACTOR, INDEMNITY & C.		
		IN CONTRACTOR'S PROPERTY SHALL BE		
		HELD FOR CONSIDERATION BY THE		
		OWNER. CONTRACTOR SHALL BE		
		RESPONSIBLE FOR ANY DAMAGE TO		
		PROPERTY AND EQUIPMENT LOCATED		
		ON OR NEAR THE PROJECT SITE.		
		ALL RIGHTS TO ANY PATENTS, TRADE		
		MARKS, AND OTHER INTELLECTUAL		
		PROPERTY ARE RESERVED BY TICO MANUFACTURING		
		OR ITS AFFILIATES.		
SIZE	D	DWG. NO.	91779-A1	REV
SCALE	1:2	WEIGHT	3.02	SHEET 1 OF 1

D 91779-A1

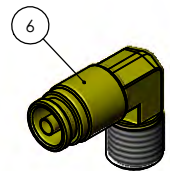
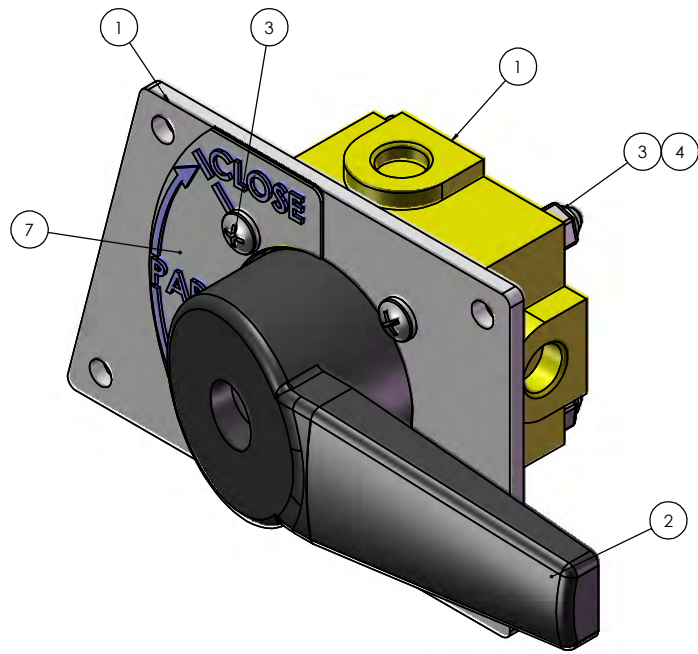

DIMENSIONS ARE IN INCHES		NAME	DATE	TICO MANUFACTURING 44 CYPRESS RIDGE DR. ROCKLAND, SC 29554 TICORACTORS.COM
TOLERANCES:	DECIMAL	DRAWN	ADW	
	.005	CHECKED		
	.010	APPROVED		
	.015	DO NOT SCALE DRAWING		
	.030	THE SUBJECT MATTER SHOWN AND DESCRIBED IN THIS DRAWING AND ANY OTHER INFORMATION CONTAINED IN CONNECTION HEREWITH IS TO BE CONSIDERED AS NOT BEING A CONTRACT AND ALL RIGHTS TO ANY PATENTS, TRADE MARKS, AND COPYRIGHTS RESERVED ARE RESERVED BY TICO MANUFACTURING, INC.		
INSPIRE GEOMETRIC TOOLERWORKING FOR NAME & DRAWING		TITLE: ASSEMBLY, PANEL DASH DOOR VALVE		
DATE:		SIZE:	DWG. NO.:	REV:
REV:		D	20183-A1	
ISSUES:		SCALE:	1:1	WEIGHT:
				SHEET 1 OF 1

D 20183-A1

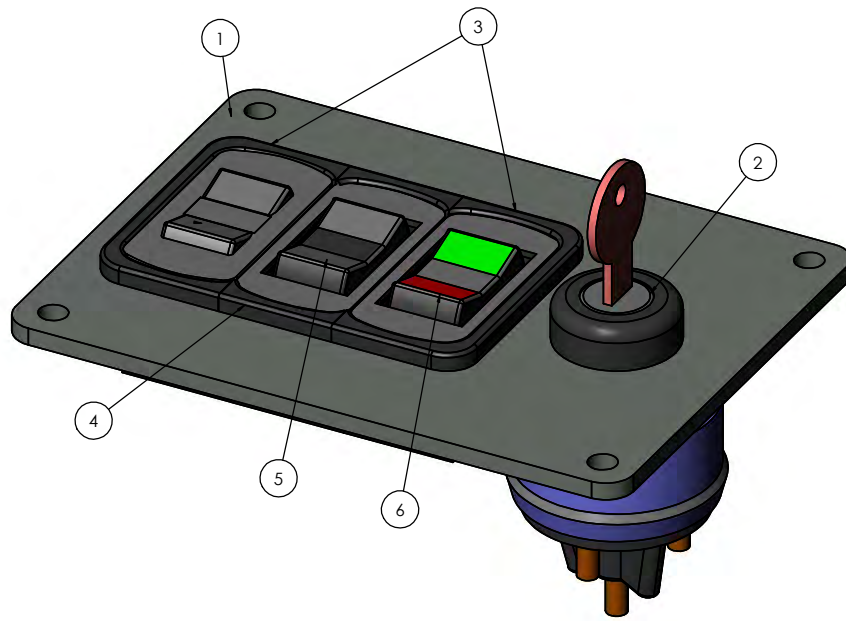

DIMENSIONS ARE IN INCHES		NAME	DATE	TICO MANUFACTURING
TOLERANCES:		DRAWN	ADW	66 CYPRESS RIDGE DR.
DECIMAL	.0005	CHECKED		ROCKLAND, NC 27854
FRACTIONAL	0.001	APPROVED		TICORACTORS.COM
ANGULAR	0.1°	DO NOT SCALE DRAWING		
INSURE GEOMETRIC TOLERANCING PER ASME Y14.5M		THE SUBJECT MATTER SHOWN AND DESCRIBED IN THIS DRAWING AND ANY OTHER INFORMATION CONTAINED IN CONNECTION HEREWITH IS TO BE REPRODUCED IN WHOLE OR IN PART WITHOUT THE WRITTEN CONSENT OF TICO MANUFACTURING AND COMPANY. ALL RIGHTS TO ANY PATENTS, TRADE MARKS AND COPYRIGHTS NOTICED ARE RESERVED BY TICO MANUFACTURING AND COMPANY.		
DATE		SIZE	DWG. NO.	REV
ISSUES		D	91605-A1	
		SCALE: 1:1	WEIGHT: 0.38	SHEET 1 OF 1

D 91605-A1

