

DETAIL E
SCALE 1 : 2

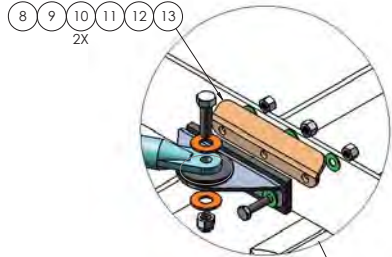

DETAIL B
SCALE 1 : 2

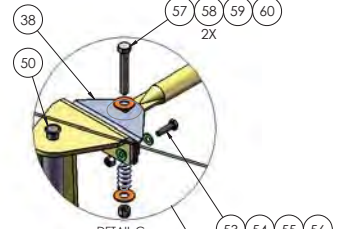

DETAIL G
SCALE 1 : 3

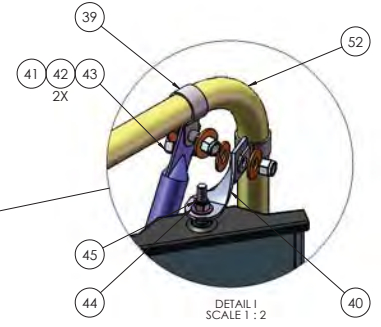

DETAIL I
SCALE 1 : 2

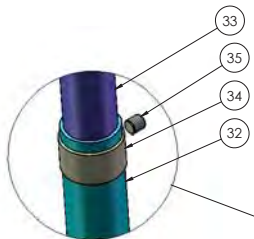

DETAIL D
SCALE 1 : 1

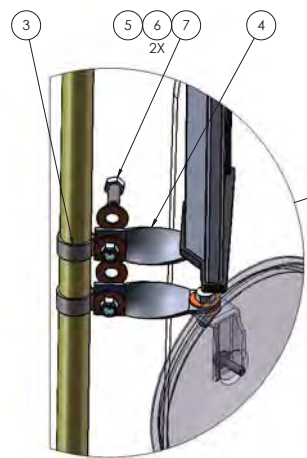

DETAIL A
SCALE 1 : 2

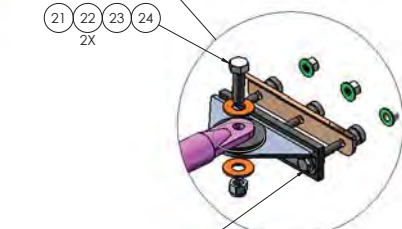
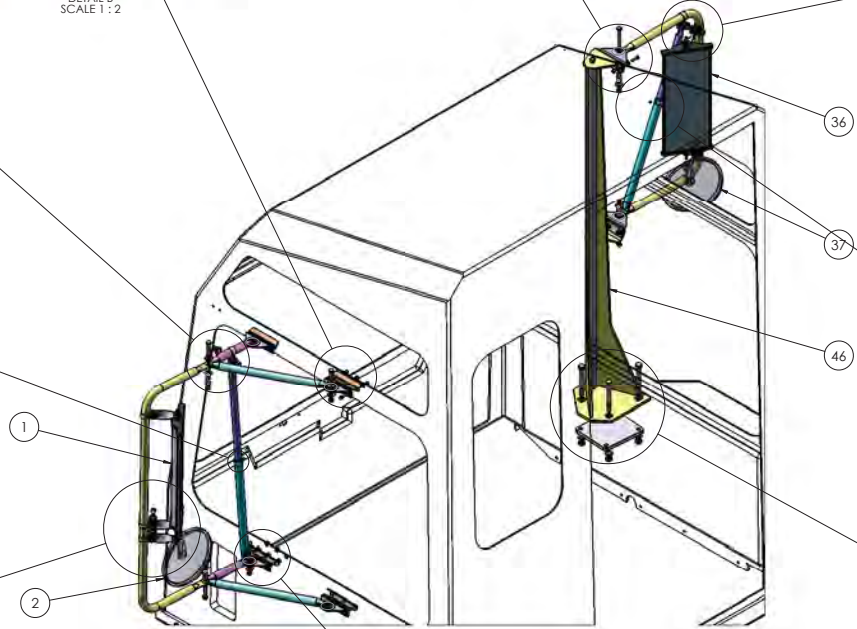

DETAIL AE
SCALE 1 : 2

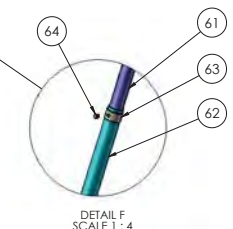

DETAIL F
SCALE 1 : 4

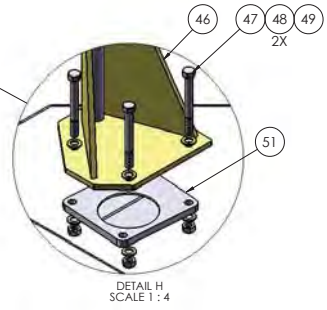

DETAIL H
SCALE 1 : 4



DETAIL AE
SCALE 1 : 2

UNITS: DIMENSIONS ARE IN INCHES	DATE: 9/21/14	SCALE: 1:50	WEIGHT: 720826-C1	SHEET 1 OF 1
TOLERANCES:	FRAC.	DEC.	ANG.	WELD.
FRAC.	0.001	0.0005	0.001	0.001
DEC.	0.001	0.0005	0.001	0.001
ANG.	0.001	0.0005	0.001	0.001
WELD.	0.001	0.0005	0.001	0.001
ASSEMBLY GEOMETRIC TOLERANCES:	FORM	POSITION	ORIENTATION	RUNOUT
FORM	0.001	0.001	0.001	0.001
POSITION	0.001	0.001	0.001	0.001
ORIENTATION	0.001	0.001	0.001	0.001
RUNOUT	0.001	0.001	0.001	0.001
REVISIONS:	NO. 1	DATE	DESCRIPTION	BY
1	1	9/21/14	ISSUED FOR MANUFACTURE	WED
THE SUBJECT MATTER SHOWN AND DESCRIBED IN THE DRAWING AND ANY INFORMATION CONTAINED THEREIN IS THE PROPERTY OF WED GROUP, INC. AND IS TO BE KEPT CONFIDENTIAL BY ALL PERSONS TO WHOM IT IS LOANED OR COPIED. NO REPRODUCTION OR TRANSMISSION IN ANY FORM OR BY ANY MEANS, ELECTRONIC OR MECHANICAL, INCLUDING PHOTOCOPYING, RECORDING, OR BY ANY INFORMATION STORAGE AND RETRIEVAL SYSTEM, IS PERMITTED WITHOUT THE WRITTEN PERMISSION OF WED GROUP, INC.				
TITLE: MOTORIZED MIRROR (R) STATIC MIRROR (L)		SIZE: D DWG. NO.: 720826-C1	REV:	SCALE: 1:50

TICO PRO-SPOTTER				
S/N:		MIRRORS, MOTORIZED RIGHT SIDE,STATIC LEFT SIDE		720826
ITEM	PART #	QTY/M	DESCRIPTION	
25	50234	1	LOOP, MIRROR 11"	
26	50242	2	BRACE, HORIZONTAL, MIRROR FWD	
27	50235	2	BRACE, HORIZONTAL, MIRROR AFT	
28	80318	2	BOLT, HEX 3/8-16 X 2 3/4 LONG STAINLESS STEEL	
29	80314	4	WASHER, FLAT, 3/8 STAINLESS STEEL	
30	50250	2	SPRING, COMPRESSION, STAINLESS STEEL	
31	80320	2	NUT, LOCK, NYLON, 3/8-16 HEX STAINLESS STEEL	
32	50237	1	STABLIZER TUBE, OUTER	
33	50254	1	STABLIZER TUBE, INNER	
34	50255	2	COLLAR, STABLIZERTUBE	
35	50256	2	SET SCREW, COLLAR	
36	50180	1	MIRROR, MOTORIZED, HEATED, RIGHT HAND	
37	90697	1	MIRROR, CONVEX, HEATED	
38	50238	2	MOUNT, MIRROR ANGLE	
39	50239	3	CLAMP, 1"	
40	50240	2	BRACKET, TWISTED	
41	82372	3	BOLT, HEX 3/8-16 X 1 LONG STAINLESS STEEL	
42	80314	8	WASHER, FLAT, 3/8 STAINLESS STEEL	
43	80320	5	NUT, LOCK, NYLON, 3/8-16 HEX STAINLESS STEEL	
44	80313	3	WASHER, FLAT, 5/16 STAINLESS STEEL	
45	80319	3	NUT, LOCK, NYLON, 5/16-18 HEX, STAINLESS STEEL	
46	91937	1	STANCHION, MIRROR VEE, GALVANIZED	
47	82528	4	BOLT, HEX 1/2-13 X 4 1/2 LONG	
48	85093	8	WASHER, FLAT 1/2"	
49	85027	4	NUT, LOCK, NYLON, 1/2NC	
50	91515-7	1	PLUG 5/8	
51	91920-5	1	CLAMP PLATE, GALVANIZED	
52	50236	1	LOOP, MIRROR 14"	
53	80361	6	BOLT, HEX 1/4-20NC X 1 LONG STAINLESS STEEL	
54	80311	12	WASHER, FLAT 1/4, STAINLESS STEEL	
55	91609	2	ISOLATOR, RUBBER	
56	80360	6	NUT, LOCK, NYLON, 1/4-20 HEX	
REV	DATE	BY		SHEET
C	9/22/2016	DFM		2 OF 2

TICO MANUFACTURING - RIDGELAND, SC 29936

REV.	DESCRIPTION	ECN	DATE	APPROVED
A	RELEASE	14319	5/27/2014	

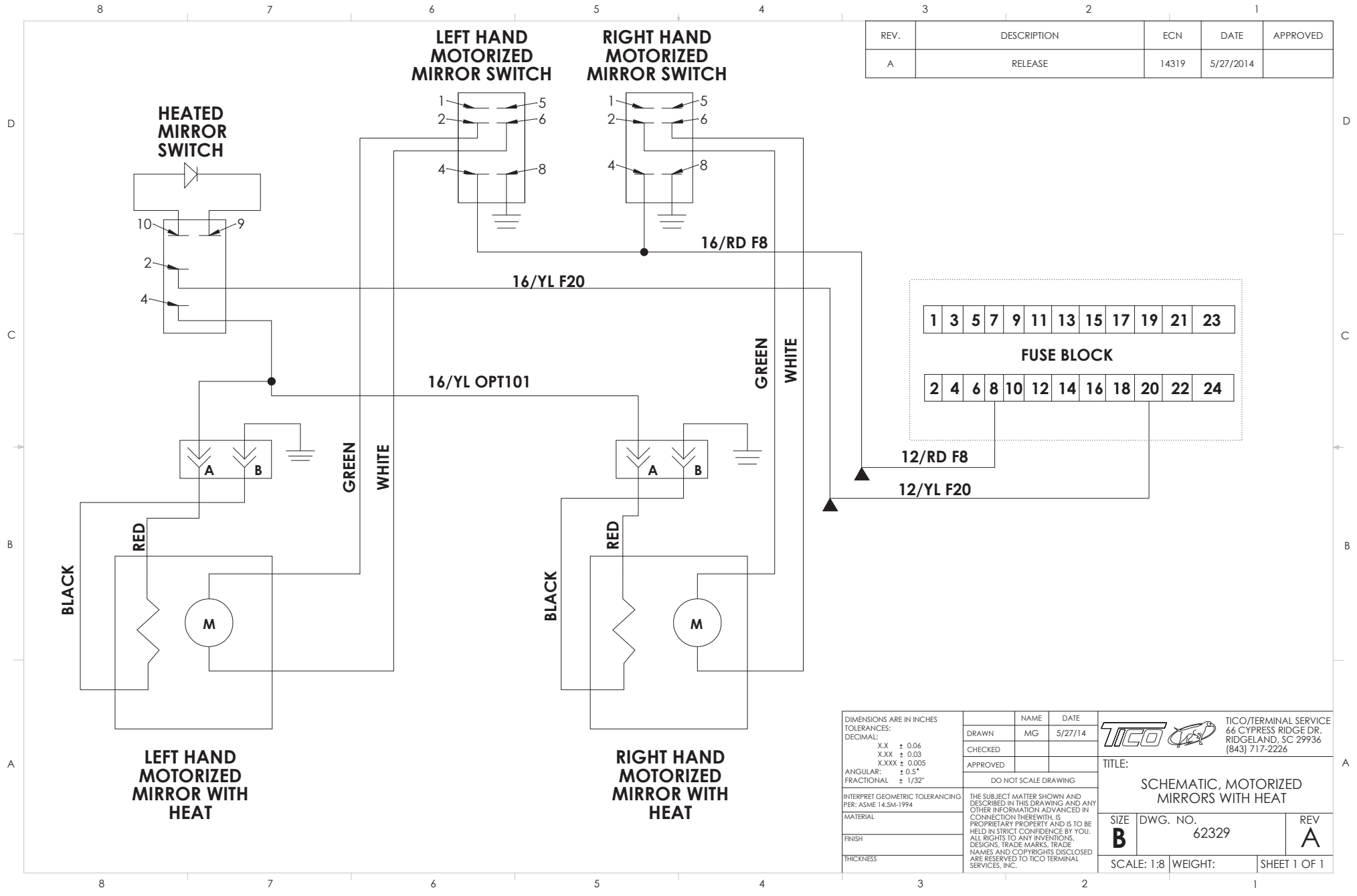

DIMENSIONS ARE IN INCHES		NAME	DATE	 TICO/TERMINAL SERVICE 66 CYPRESS RIDGE DR. RIDGELAND, SC 29936 (843) 717-2226
TOLERANCES:		DRAWN	MG 5/27/14	
DECIMAL:		CHECKED		
X.X ± 0.06 X.XX ± 0.03 X.XXX ± 0.005		APPROVED		
ANGULAR: ± 0.5°		DO NOT SCALE DRAWING		TITLE:
FRACTIONAL: ± 1/32"				SCHEMATIC, MOTORIZED MIRRORS WITH HEAT
INTERPRET GEOMETRIC TOLERANCING PER: ASME 14.5M-1994				SIZE
MATERIAL				B
FINISH				DWG. NO.
THICKNESS				62329
				REV
				A
				SCALE: 1:8
				WEIGHT:
				SHEET 1 OF 1