

DIMENSIONS ARE IN INCHES		NAME	DATE	TICO MANUFACTURING 44 CYPRESS RIDGE DR. ROSELAND, NC 27068 (843) 717-2226
TOLERANCES:		DRAWN	ADW	
DECIMAL	.0005	BY	8/18	
	.001	XXX	8/10/13	
	.005	XXX	8/20/13	
ANGULAR	± 0.1°	APPROVED		
FRACTIONAL	± 0.015"	DO NOT SCALE DRAWING		
		THE SUBJECT MATTER SHOWN AND DESCRIBED IN THIS DRAWING AND ANY OTHER REPRESENTATION, INCLUDING CONSTRUCTION ASSEMBLY & REVISIONS, IS THE PROPERTY OF TICO MANUFACTURING. IT IS TO BE USED ONLY FOR THE PROJECT AND FOR THE PURPOSES SPECIFICALLY IDENTIFIED HEREIN. ANY OTHER USE, REPRODUCTION, OR DISSEMINATION OF THIS DRAWING WITHOUT THE WRITTEN PERMISSION OF TICO MANUFACTURING IS PROHIBITED.		
UNITS	IN/IN	SIZE	DWG. NO.	REV
IN/IN	IN/IN	D	720808-A1	
SEE NOTE		SCALE	1:4	WEIGHT: 19.69
SECRET				SHEET 1 OF 1

720808-A1

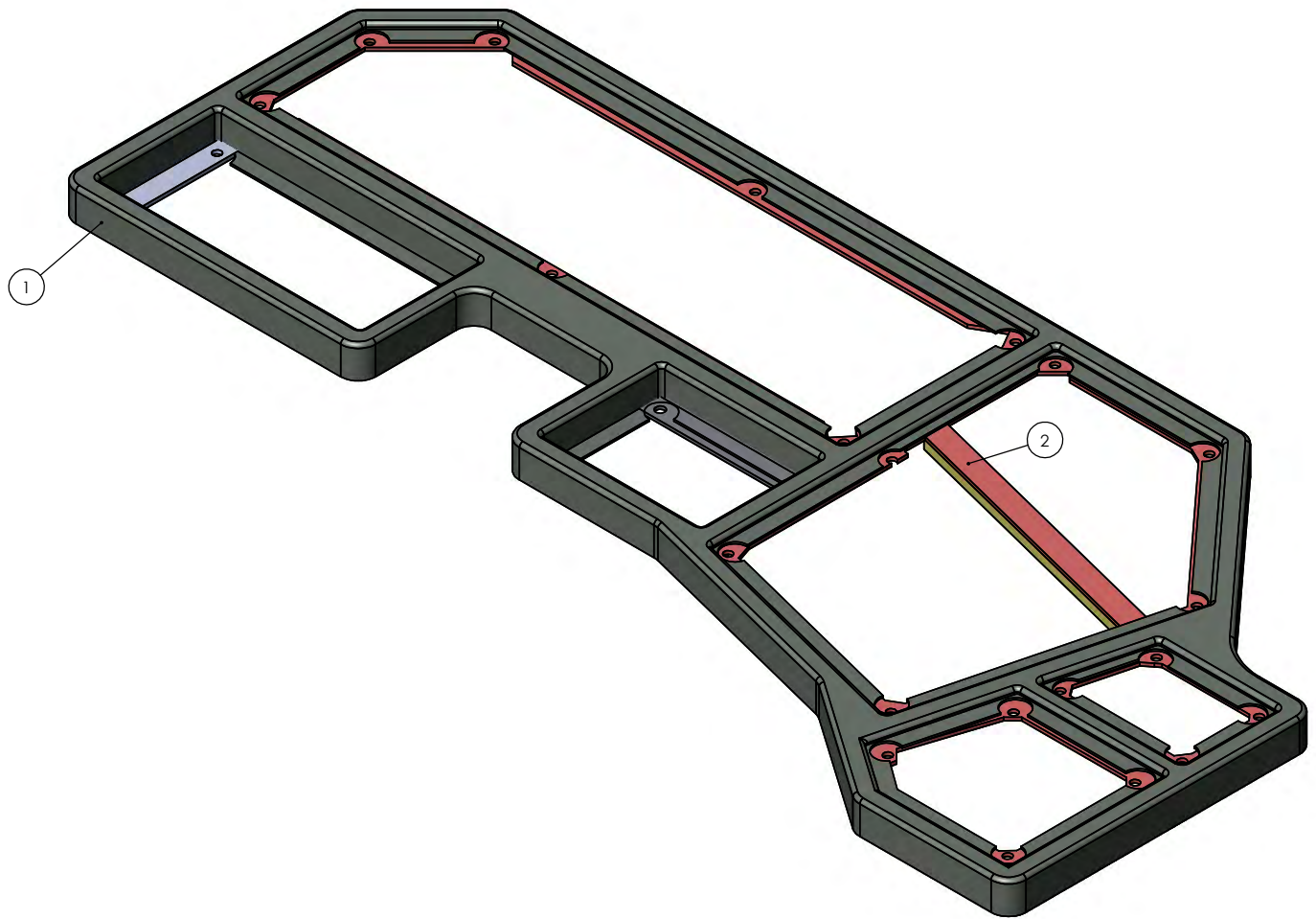

DIMENSIONS ARE IN INCHES		NAME	DATE	TICO MANUFACTURING	
TOLERANCES:		DRAWN	ADW	06/22/2020	44 CYPRESS RIDGE DR.
DECIMAL	.XX	CHECKED			ROCKLAND, NC 29154
	.XXX	APPROVED			TICORACTORS.COM
FRACTIONAL	1/16 & 3/32	DO NOT SCALE DRAWING			
ANGULAR	± 0.1°	THE SUBJECT MATTER SHOWN AND			
FRACTIONAL	± 1/16	DESCRIBED IN THIS DRAWING AND ANY			
INSURE GEOMETRIC TOLERANCING		OTHER REFERENCE IS INVOLVED IN			
PER ASME Y14.5M-1994		CONSTRUCTION AND DIMENSIONS TO BE			
		RECORDED IN THE OFFICE OF THE			
		ALL RIGHTS TO ANY INVENTIONS			
		HEREIN RESERVED AND WILL REMAIN THE			
		PROPERTY OF TICO MANUFACTURING			
		AND NO OTHER REPRODUCTION			
		IS PERMITTED WITHOUT THE WRITTEN			
		CONSENT OF TICO MANUFACTURING			
		CORPORATION			

TICO
 TITLE: DASH COVER ASSEMBLY ISB
 10
 SIZE DWG. NO. 91646-A1 ILL REV
 D SCALE: 1:4 WEIGHT: 7.29 SHEET 1 OF 1

91646-A1 ILL 10/1

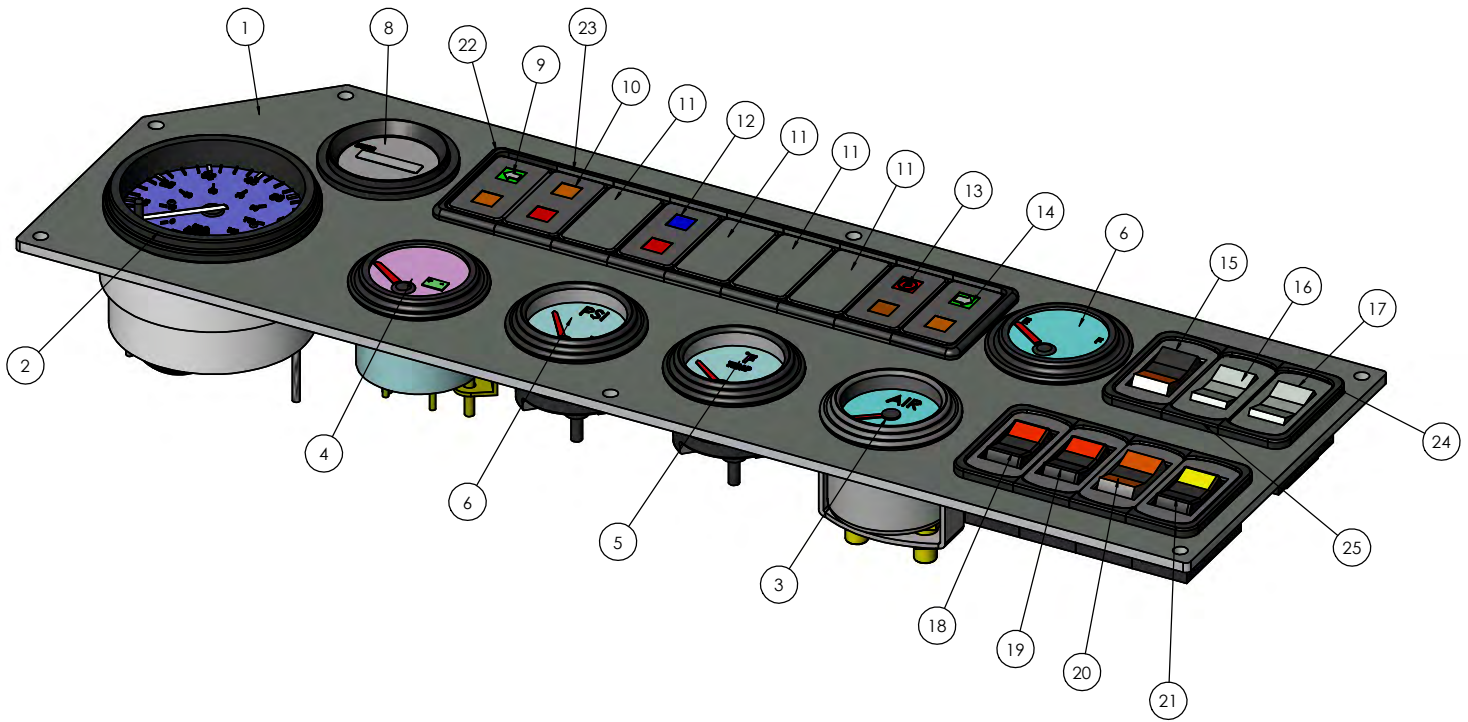

DIMENSIONS ARE IN INCHES		NAME	DATE	TICO MANUFACTURING
TOLERANCES:	DECIMAL	DRAWN	ADW	66 CYPRESS RIDGE DR.
	.005	CHECKED		ROCKLAND, SC 29574
	.010	APPROVED		TICORACTORS.COM
	.015			
	.020			
ANGULAR:	± 1.0°	DO NOT SCALE DRAWING		
FRACTIONAL:	± .005	THE SUBJECT MATTER SHOWN AND		
		DESCRIBED IN THIS DRAWING AND ANY		
		OTHER REFERENCE DRAWINGS IN		
		CONNECTION ASSEMBLY IS TO BE		
		REPRODUCED IN ANY MANNER OR FOR		
		ALL RIGHTS TO ANY PATENTS OR		
		OTHER INTELLECTUAL PROPERTY		
		HEREIN ARE RESERVED TO TICORACTORS		
		MANUFACTURING, INC.		
TICORACTORS		SIZE	DWG. NO.	REV
		D	91910-A1	
		SCALE: 1:2	WEIGHT: 3.95	SHEET 1 OF 1

D 91910-A1

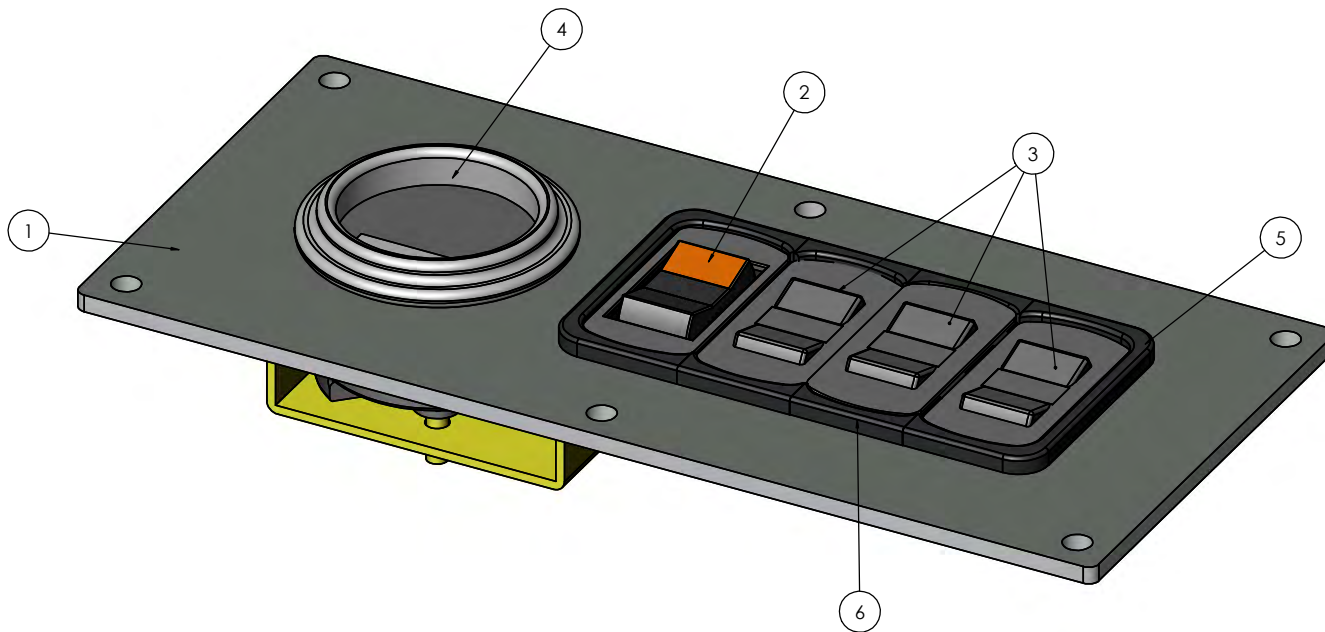

DIMENSIONS ARE IN INCHES		NAME	DATE	TICO MANUFACTURING
TOLERANCES:		DRAWN	ADW	11/24/11
DECIMAL	.0005	CHECKED		44 CYPRESS RIDGE DR.
FRACTIONAL	1/16 & 32	APPROVED		ROCKLAND, NC 27854
ANGULAR	± 0.1°	DO NOT SCALE DRAWING		TICORFACTORS.COM
INSURE GEOMETRIC TOLERANCING PER ASME Y14.5M		THE SUBJECT MATTER SHOWN AND DESCRIBED IN THIS DRAWING AND ANY OTHER INFORMATION CONTAINED HEREIN IS THE PROPERTY OF TICO MANUFACTURING AND IS TO BE KEPT IN CONFIDENCE BY ALL PERSONS TO WHOM IT IS FURNISHED. NO PARTS, INFORMATION, PHOTOGRAPHS, REPRODUCTIONS, COPIES, OR OTHER INFORMATION ARE TO BE REPRODUCED OR TRANSMITTED IN ANY FORM OR BY ANY MEANS, ELECTRONIC OR MECHANICAL, INCLUDING PHOTOCOPYING, RECORDING, OR BY ANY INFORMATION STORAGE AND RETRIEVAL SYSTEM.		TITLE
				ASSY PANEL
				HOURLY/DIAGNOSTIC -
				ISB 10 KPH
SIZE	DWG. NO.	REV		
D	90604-A1			
SCALE: 1:1	WEIGHT: 0.55	SHEET 1 OF 1		

D 90604-A1

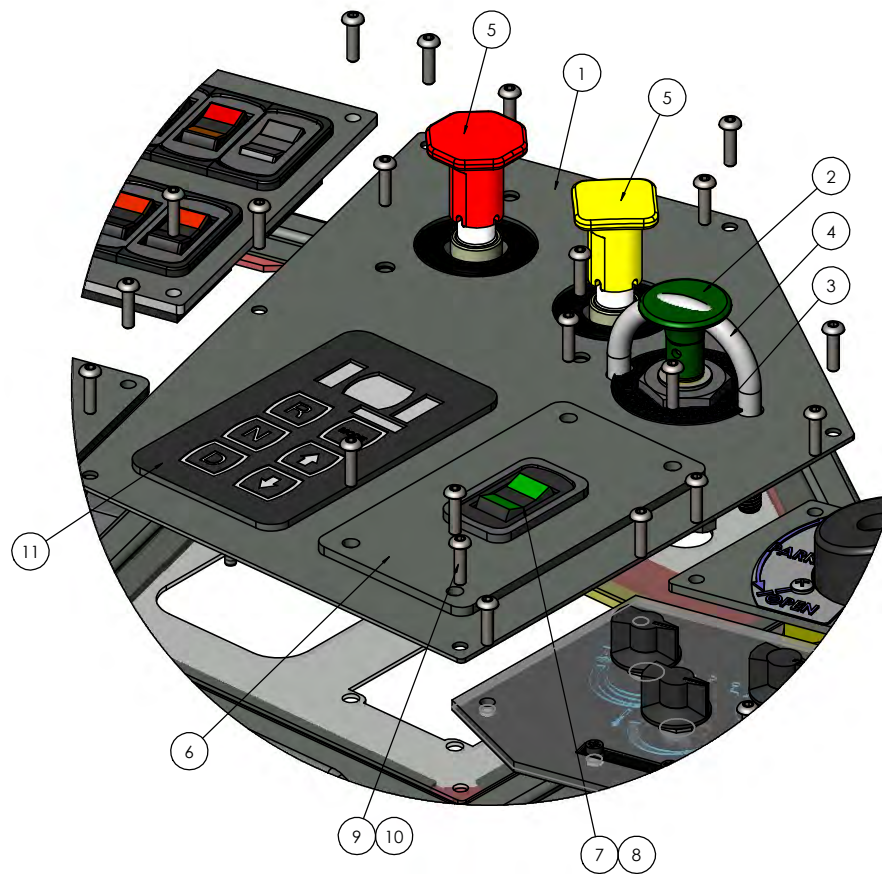

DIMENSIONS ARE IN INCHES		NAME	DATE	TICO MANUFACTURING
TOLERANCES:	DECIMAL	DRAWN	ADW	66 CYPRESS RIDGE DR.
	.005	CHECKED		ROCKLAND, SC 29554
	.010	APPROVED		TICORACTORS.COM
	.015			
	.020			
ANGULAR:	± 1.0°	DO NOT SCALE DRAWING		
FRACTIONAL:	± .005	THE SUBJECT MATTER SHOWN AND		
		DESCRIBED IN THIS DRAWING AND ANY		
		OTHER REFERENCE IS ADVANCED BY		
		CONTRACTOR HEREIN AND IS TO BE		
		REGARDLESS OF ANY CONTRACTS OR		
		AGREEMENTS. CONTRACTOR SHALL		
		VERIFY ALL DIMENSIONS AND		
		MATERIALS AND COMPONENTS USED		
		ARE SHOWN TO BE IN ACCORDANCE		
		WITH THE DRAWING.		
TITLE:		DASH PANEL-PB		
SIZE:		DWG. NO. 20116-A1 ILL		
SCALE:		1:4 WEIGHT: 18.03 SHEET 1 OF 1		

D 20116-A1 ILL 001



DIMENSIONS ARE IN INCHES		NAME	DATE	TICO MANUFACTURING
TOLERANCES:		DRAWN	ADW	04/22/2020
DECIMAL	.005	CHECKED		44 CYPRESS RIDGE DR.
FRACTIONAL	1/32	APPROVED		ROCKLAND, NC 27854
ANGULAR	± 0.1°			TICORACTORS.COM
FUNCTIONAL	± 0.005			
DO NOT SCALE DRAWING		TITLE: HEATER CONTROL ASSEMBLY		
INSURE GEOMETRIC TOLERANCING PER ASME Y14.5M		THE SUBJECT MATTER SHOWN AND DESCRIBED IN THIS DRAWING AND ANY OTHER INFORMATION CONTAINED HEREIN IS THE PROPERTY OF TICO MANUFACTURING, INC. AND IS TO BE KEPT IN CONFIDENCE BY ALL PARTS TO WHOM IT IS FURNISHED. NO PARTS, INFORMATION, DRAWINGS, OR CONCEPTS DISCLOSED HEREIN ARE TO BE REPRODUCED OR USED IN ANY MANNER WITHOUT THE WRITTEN PERMISSION OF TICO MANUFACTURING, INC.		
DATE:	04/22/2020	SIZE	DWG. NO.	REV
REVISIONS:		D	20900-A1 ILL	
		SCALE: 1:1	WEIGHT: 0.27	SHEET 1 OF 1

D 20900-A1 ILL 001