

DETAIL B
SCALE 1 : 2

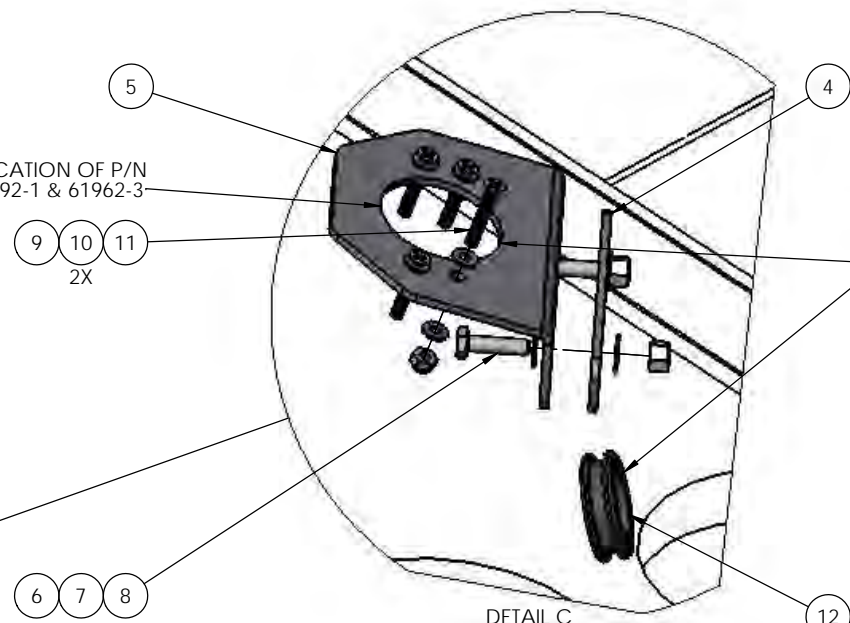
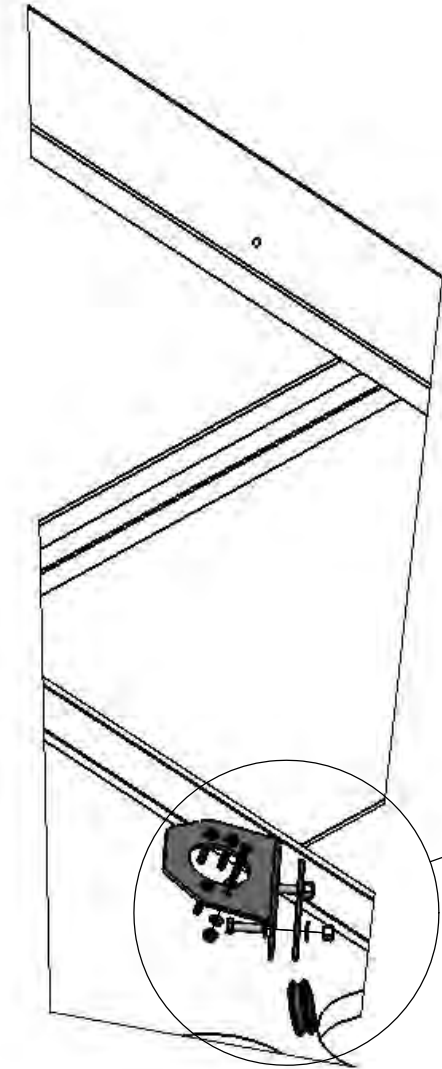

DETAIL C
SCALE 1 : 2

DIMENSIONS ARE IN INCHES

TOLERANCES:	NAME	DATE
DECIMAL:	DRAWN	SMB 10/23/2013
XX ± 0.06	REVISED	MPC 08/18/2016
XXX ± 0.03	APPROVED	
XXXX ± 0.005	DO NOT SCALE DRAWING	
ANGULAR:	THE SUBJECT MATTER SHOWN AND DESCRIBED IN THIS DRAWING AND ANY OTHER INFORMATION ADVANCED IN CONNECTION THEREWITH IS PROPRIETARY PROPERTY AND IS TO BE HELD IN STRICT CONFIDENCE BY YOU. ALL RIGHTS TO ANY INVENTIONS, DESIGNS, TRADE MARKS, TRADE NAMES AND COPYRIGHTS DISCLOSED ARE RESERVED TO TICO TERMINAL SERVICES, INC.	
FRACTIONAL	INTERPRET GEOMETRIC TOLERANCING PER: ASME 14.5M-1994	
± 1/32"	MATERIAL	
	FINISH	
	THICKNESS	

SIZE	DWG. NO.	REV
C	72075-C1	

TICO/TERRMINAL SERVICE
66 CYPRESS RIDGE DR.
RIDGELAND, SC 29936
(843) 717-2226

TICO

TITLE:
GOLIGHT, STRYKER 3020

SHEET 1 OF 1

