

DETAIL B
SCALE 1 : 2

LOCATION OF P/N 91692

1 2 3
2X

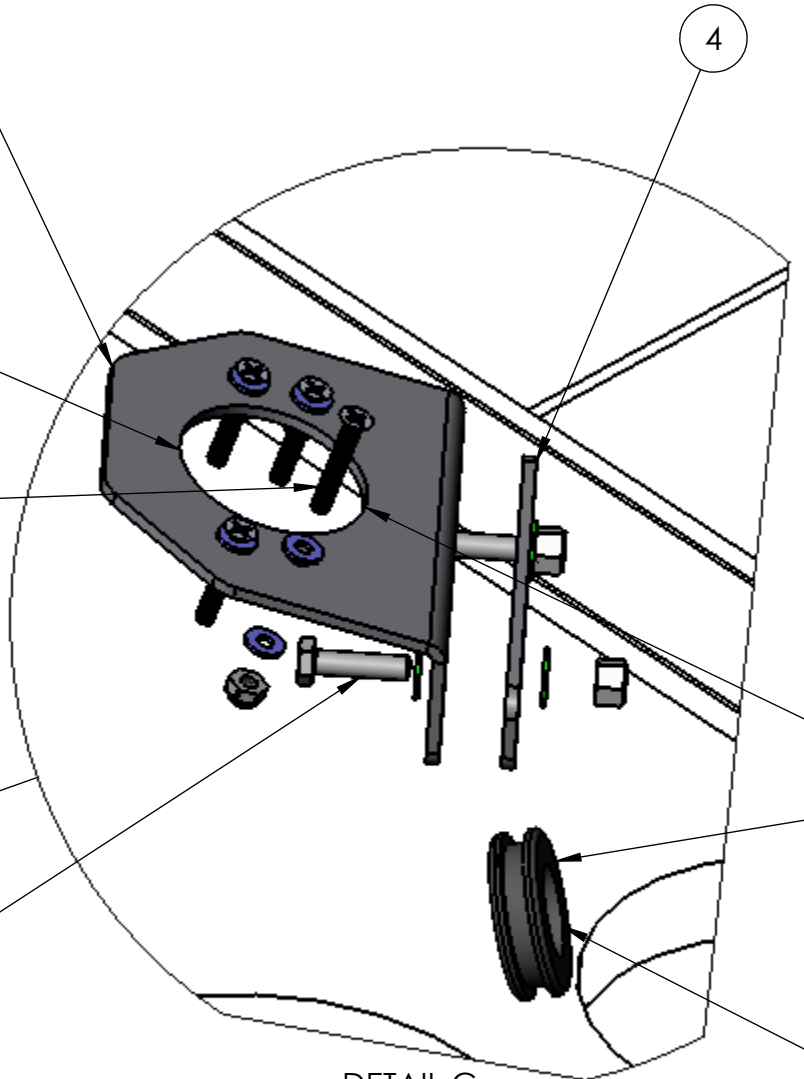
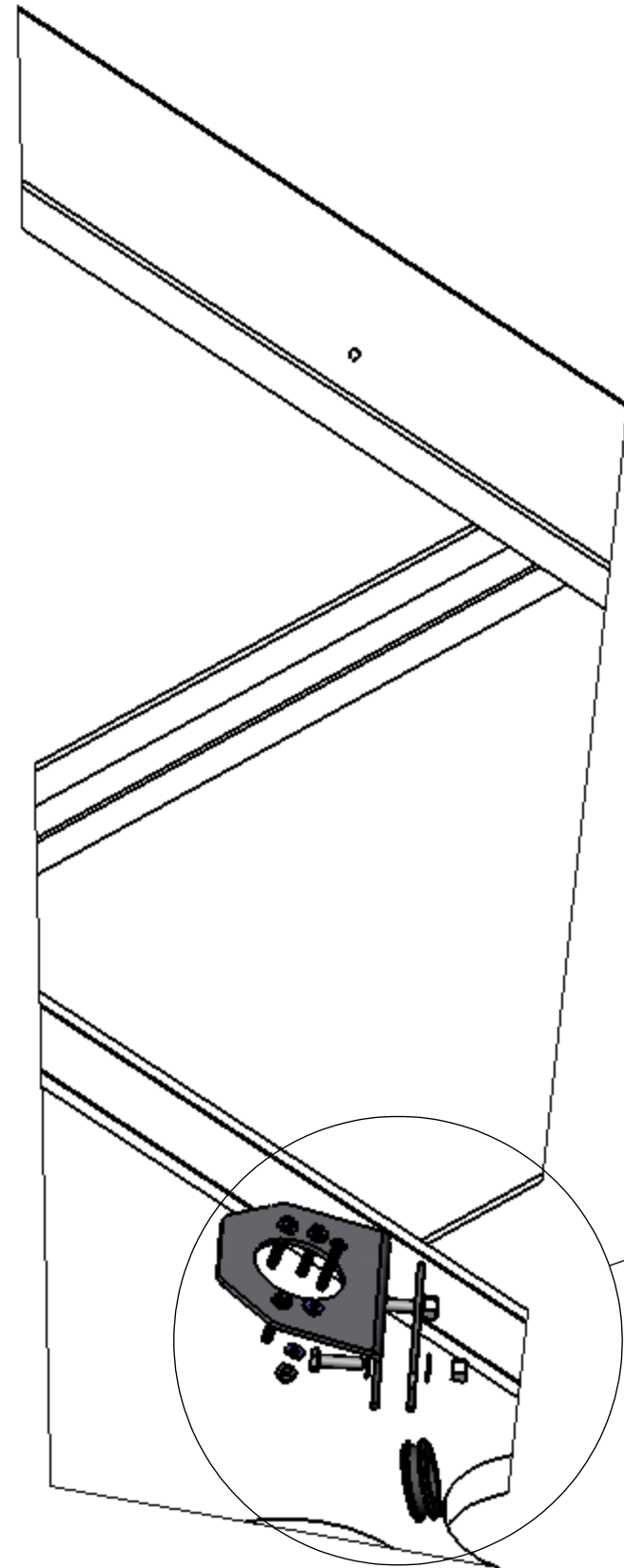

DETAIL C
SCALE 1 : 2

LOCATION OF P/N 91692-1 & 61962-3

LOCATION OF P/N 91692-2

9 10 11
2X

6 7 8
2X

DIMENSIONS ARE IN INCHES		NAME	DATE	TICO/TERMINAL SERVICE 66 CYPRESS RIDGE DR. RIDGELAND, SC 29936 (843) 717-2226
TOLERANCES:		DRAWN	SMB 10/23/13	
DECIMAL:		REVISED	DFM 2/22/216	
X.X ± 0.06 X.XX ± 0.03 X.XXX ± 0.005 ANGULAR: ± 0.5° FRACTIONAL: ± 1/32"		APPROVED		TITLE:
INTERPRET GEOMETRIC TOLERANCING PER: ASME 14.5M-1994		DO NOT SCALE DRAWING		GOLIGHT, STRYKER 3020
MATERIAL		THE SUBJECT MATTER SHOWN AND DESCRIBED IN THIS DRAWING AND ANY OTHER INFORMATION ADVANCED IN CONNECTION THEREWITH IS PROPRIETARY PROPERTY AND IS TO BE HELD IN STRICT CONFIDENCE BY YOU. ALL RIGHTS TO ANY INVENTIONS, DESIGNS, TRADE MARKS, TRADE NAMES AND COPYRIGHTS DISCLOSED ARE RESERVED TO TICO TERMINAL SERVICES, INC.		SIZE DWG. NO. REV
FINISH		C		72075-C1
THICKNESS		SCALE:1:8		WEIGHT: 494.59 SHEET 1 OF 1

