

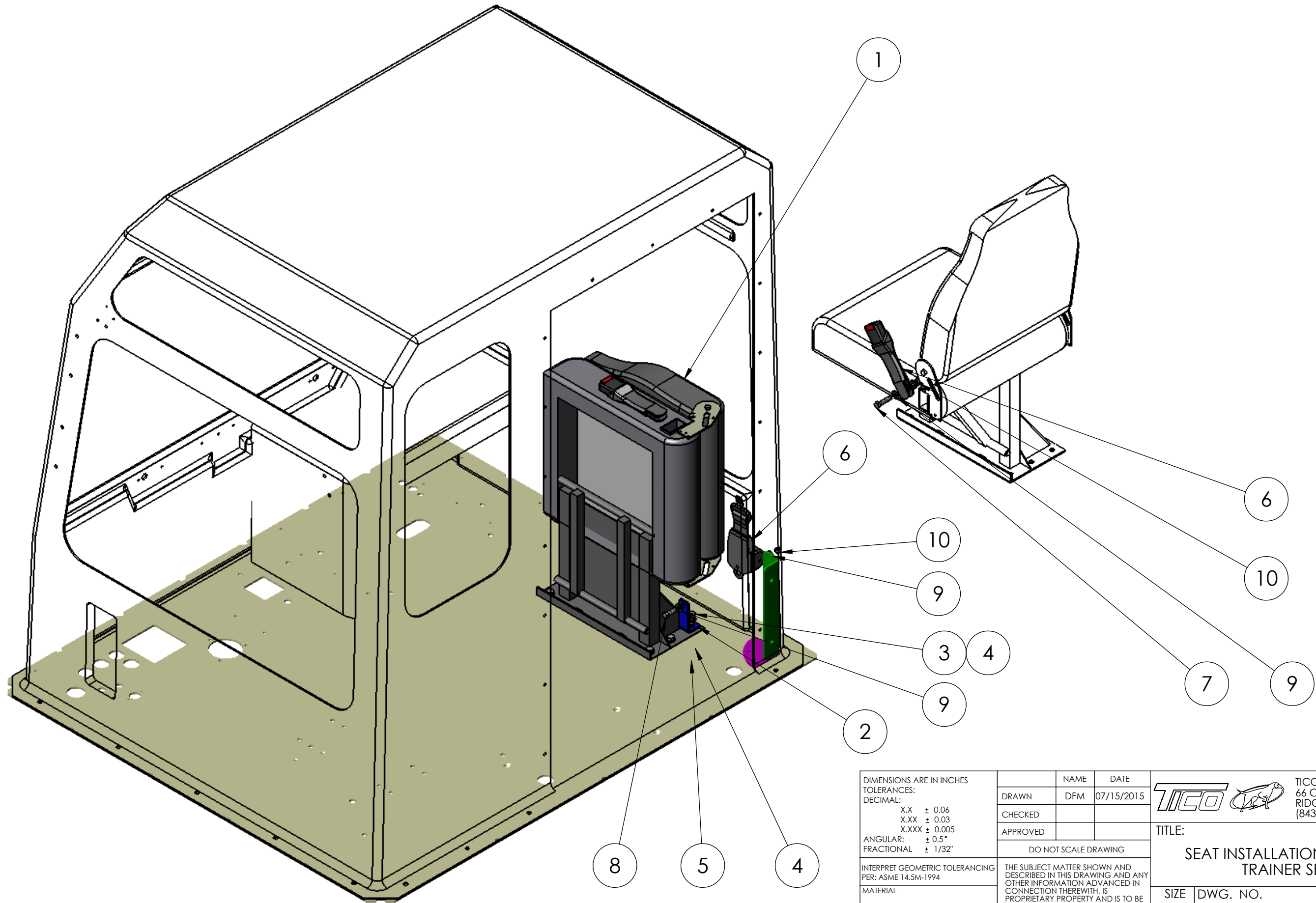

8 7 6 5 4 3 2 1

D
C
B
A

D
C
B
A



DIMENSIONS ARE IN INCHES		NAME	DATE	 TICO/TERMINAL SERVICE 66 CYPRESS RIDGE DR. RIDGELAND, SC 29936 (843) 717-2226
TOLERANCES:		DRAWN	DFM 07/15/2015	
DECIMAL:		CHECKED		
X.X ± 0.06 X.XX ± 0.03 X.XXX ± 0.005 ANGULAR: ± 0.5° FRACTIONAL ± 1/32"		APPROVED		
INTERPRET GEOMETRIC TOLERANCING PER: ASME 14.5M-1994		DO NOT SCALE DRAWING		TITLE:
MATERIAL				SEAT INSTALLATION-FOLDING TRAINER SEAT
FINISH				SIZE DWG. NO. REV
THICKNESS				B 71980-C1 C1
		SCALE: 1:10		SHEET 1 OF 1

