

DETAIL A  
SCALE 1 : 1

DETAIL B  
SCALE 1 : 2

DETAIL C  
SCALE 1 : 1

DIMENSIONS ARE IN INCHES		NAME	DATE	 TICO/TERMINAL SERVICE 66 CYPRESS RIDGE DR. RIDGELAND, SC 29936 (843) 717-2226
TOLERANCES:		DRAWN	SMB 3/19/15	
DECIMAL:		CHECKED		
X.X ± 0.06		APPROVED		TITLE:
X.XX ± 0.03		DO NOT SCALE DRAWING		SWITCH, DIFFERENTIAL LOCK
X.XXX ± 0.005		THE SUBJECT MATTER SHOWN AND DESCRIBED IN THIS DRAWING AND ANY OTHER INFORMATION ADVANCED IN CONNECTION THEREWITH IS PROPRIETARY PROPERTY AND IS TO BE HELD IN STRICT CONFIDENCE BY YOU. ALL RIGHTS TO ANY INVENTIONS, DESIGNS, TRADE-MARKS, TRADE NAMES AND COPYRIGHTS DISCLOSED ARE RESERVED TO TICO TERMINAL SERVICES, INC.		SIZE DWG. NO. REV
ANGULAR: ± 0.5°				C 71910-B1
FRACTIONAL: ± 1/32"				SCALE: 1:2 WEIGHT: SHEET 1 OF 1
INTERPRET GEOMETRIC TOLERANCING PER: ASME 14.5M-1994				
MATERIAL				
FINISH				
THICKNESS				

REV.	DESCRIPTION	ECN	DATE	APPROVED
2	PRODUCTION RELEASE	12549	5-10-12	MK

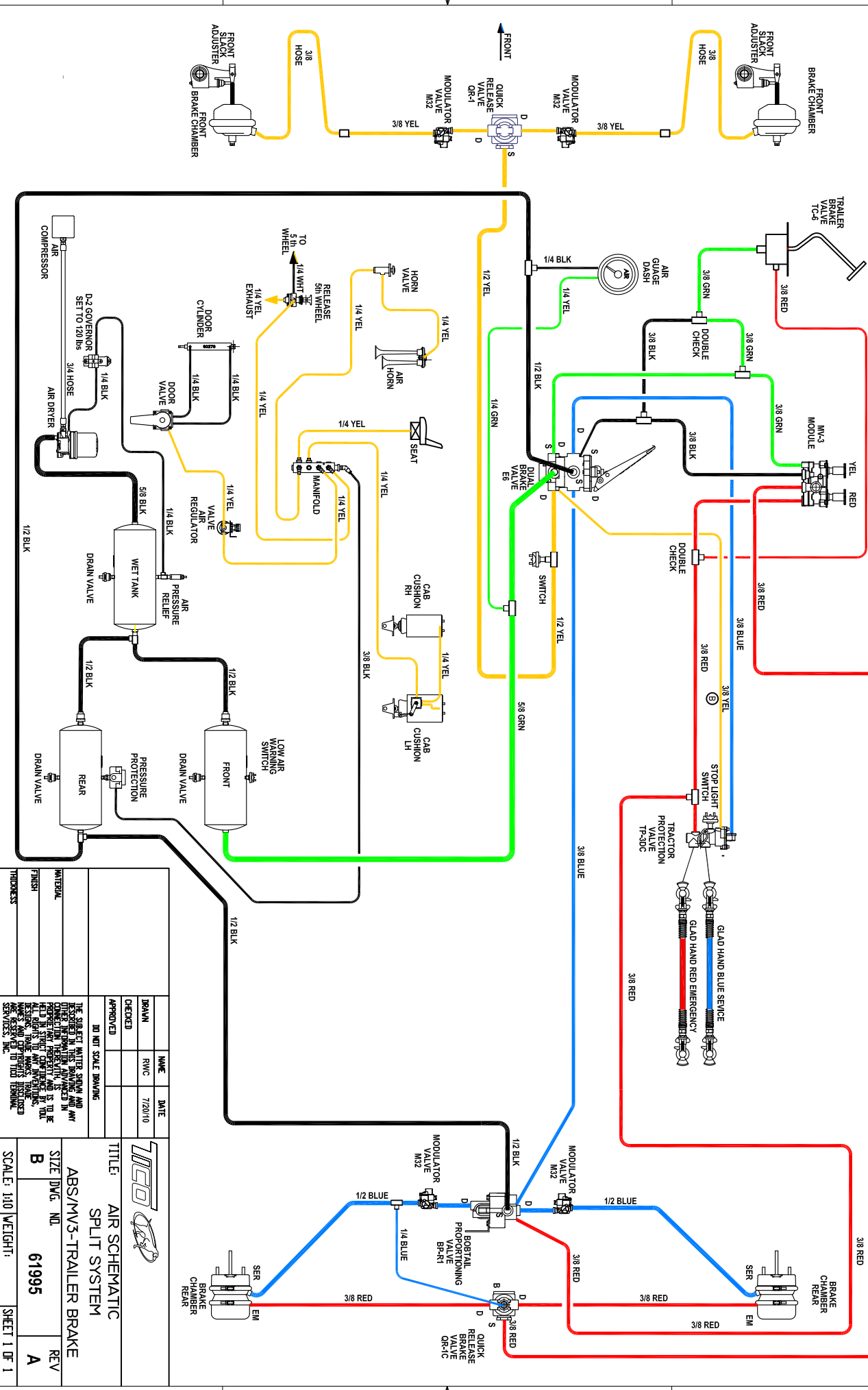

		<b>TITLE</b> AIR SCHEMATIC SPLIT SYSTEM	
<b>DO NOT SCALE DRAWING</b>		<b>DATE</b> 7/20/10	
<b>DRAWN</b> RWC		<b>NAME</b> RWC	
<b>CHECKED</b>		<b>DATE</b> 7/20/10	
<b>APPROVED</b>		<b>DATE</b> 7/20/10	
THE SUBJECT MATTER SHOWN AND ANY INFORMATION CONTAINED HEREIN IS THE PROPERTY OF IICO. IT IS TO BE USED ONLY FOR THE PROJECT AND NOT FOR ANY OTHER PURPOSE. ALL RIGHTS TO ANY PATENTS, TRADEMARKS, TRADE NAMES, TRADE DRESS, OR SERVICE MARKS ARE RESERVED TO IICO TECHNOLOGY SERVICES, INC.			
<b>SCALE:</b> 1/10 <b>WEIGHT:</b>		<b>SHEET 1 OF 1</b>	
<b>SIZE DWG. NO.</b> 61995		<b>REV</b> A	