

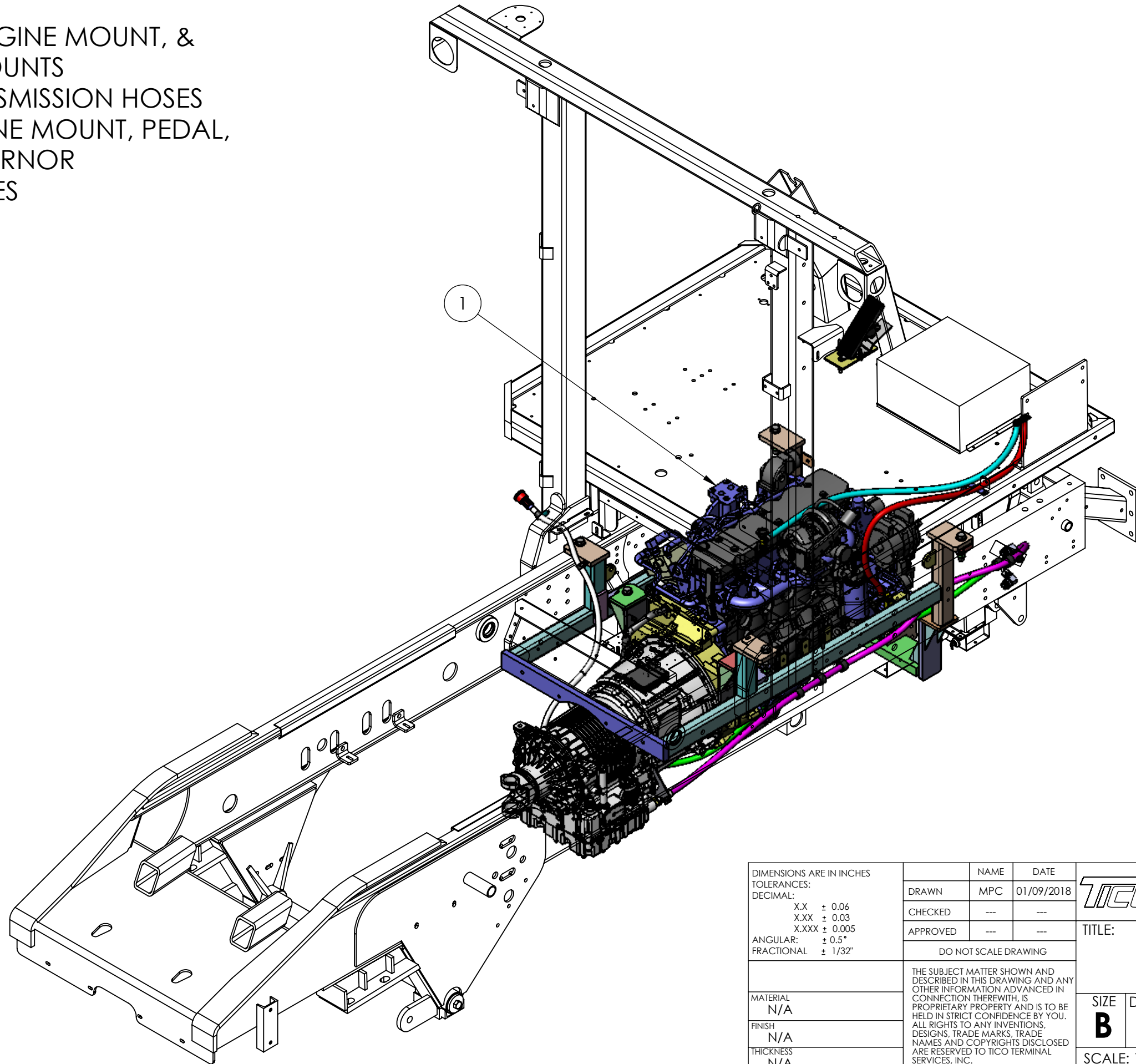

PAGE 1 : OVERVIEW
 PAGE 2 : DIPSTICK, ENGINE MOUNT, &
 CRADLE MOUNTS
 PAGE 3 : TCM & TRANSMISSION HOSES
 PAGE 4 : FRONT ENGINE MOUNT, PEDAL,
 & AIR GOVERNOR
 PAGE 5 : HEATER HOSES
 PAGES 6-8 : PARTS LIST



DIMENSIONS ARE IN INCHES TOLERANCES: DECIMAL: X.X ± 0.06 X.XX ± 0.03 X.XXX ± 0.005 ANGULAR: ± 0.5° FRACTIONAL ± 1/32"	DRAWN MPC	NAME MPC	DATE 01/09/2018	 TICO MANUFACTURING 66 CYPRESS RIDGE DR. RIDGELAND, SC 29936 (843) 717-2226
	CHECKED ---	---	---	
	APPROVED ---	---	---	
	DO NOT SCALE DRAWING			
MATERIAL N/A	THE SUBJECT MATTER SHOWN AND DESCRIBED IN THIS DRAWING AND ANY OTHER INFORMATION ADVANCED IN CONNECTION THEREWITH, IS PROPRIETARY PROPERTY AND IS TO BE HELD IN STRICT CONFIDENCE BY YOU. ALL RIGHTS TO ANY INVENTIONS, DESIGNS, TRADE MARKS, TRADE NAMES AND COPYRIGHTS DISCLOSED ARE RESERVED TO TICO TERMINAL SERVICES, INC.			TITLE: ASSEMBLY, ENGINE & TRANSMISSION
FINISH N/A	SIZE B	DWG. NO. 71838-E1	REV E	
THICKNESS N/A	SCALE: 1:16	WEIGHT:	SHEET 1 OF 5	

8 7 6 5 4 3 2 1

D
C
B
A

D
C
B
A

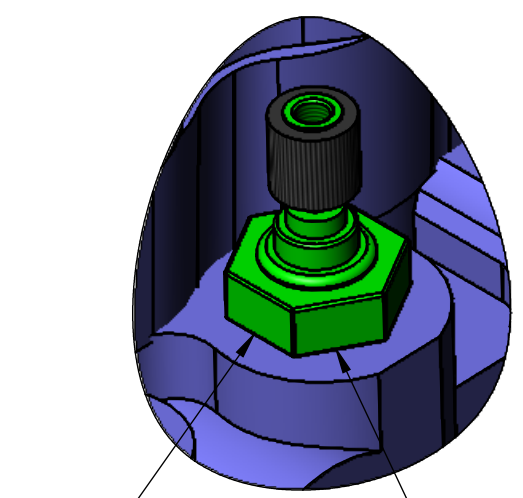

2

WATER SENSOR

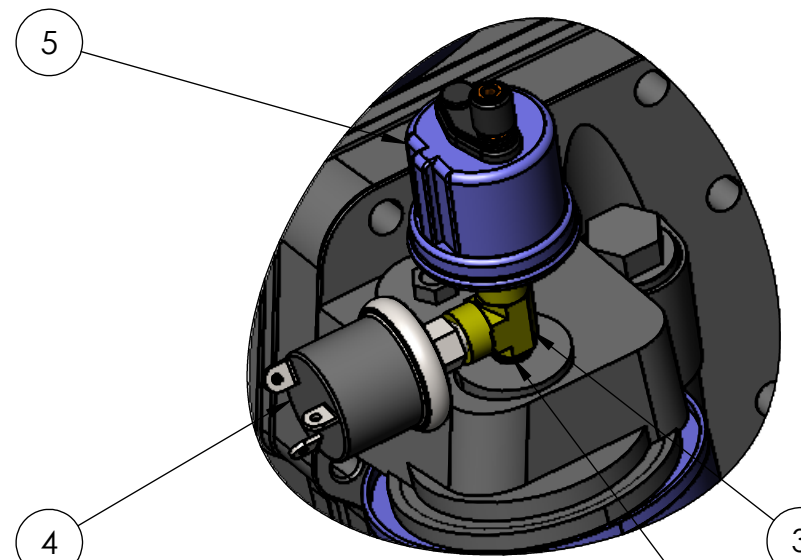

4

OIL PRESSURE SENSOR & STAT

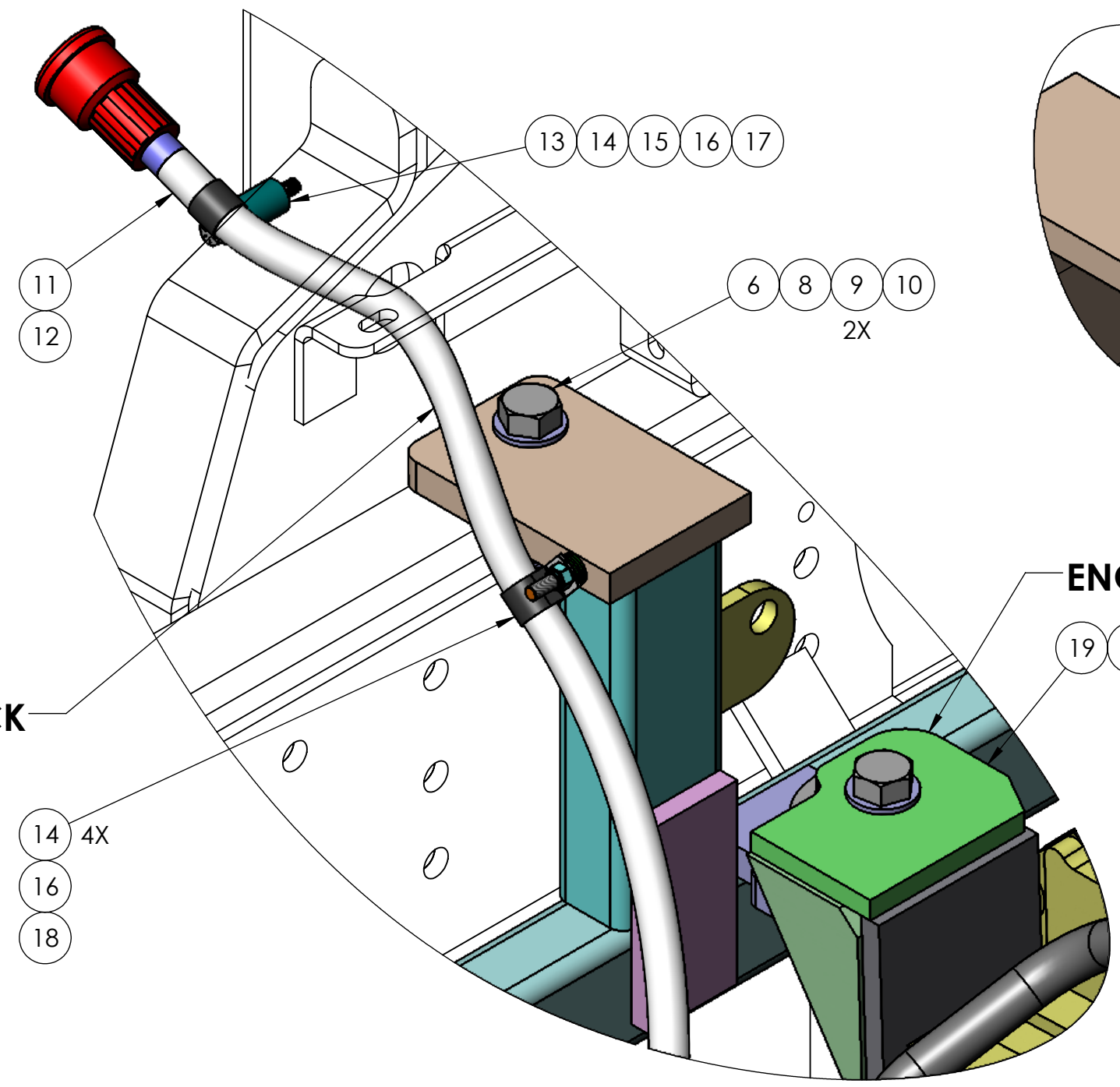

11
12

13 14 15 16 17

6 8 9 10
2X

14 4X
16
18

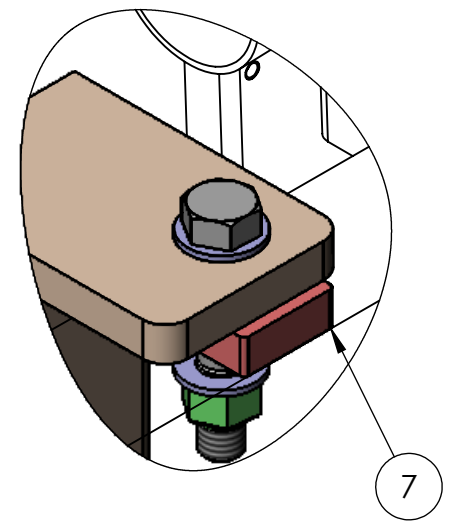

7

ENGINE MOUNT

19 21

DIMENSIONS ARE IN INCHES		NAME	DATE	 TICO/TERMINAL SERVICE 66 CYPRESS RIDGE DR. RIDGELAND, SC 29936 (843) 717-2226
TOLERANCES:		DRAWN	MPC 01/09/2018	
DECIMAL:		CHECKED	---	
X.X ± 0.06 X.XX ± 0.03 X.XXX ± 0.005 ANGULAR: ± 0.5° FRACTIONAL ± 1/32"		APPROVED	---	
INTERPRET GEOMETRIC TOLERANCING PER: ASME 14.5M-1994		DO NOT SCALE DRAWING		TITLE: ASSEMBLY, ENGINE & TRANSMISSION
MATERIAL	N/A	THE SUBJECT MATTER SHOWN AND DESCRIBED IN THIS DRAWING AND ANY OTHER INFORMATION ADVANCED IN CONNECTION THEREWITH, IS PROPRIETARY PROPERTY AND IS TO BE HELD IN STRICT CONFIDENCE BY YOU. ALL RIGHTS TO ANY INVENTIONS, DESIGNS, TRADE MARKS, TRADE NAMES AND COPYRIGHTS DISCLOSED ARE RESERVED TO TICO TERMINAL SERVICES, INC.		SIZE B
FINISH	N/A			DWG. NO. 71838-E1
THICKNESS	N/A			REV E
		SCALE: 1:16	WEIGHT:	SHEET 2 OF 5

8 7 6 5 4 3 2 1

D
C
B
A

D
C
B
A

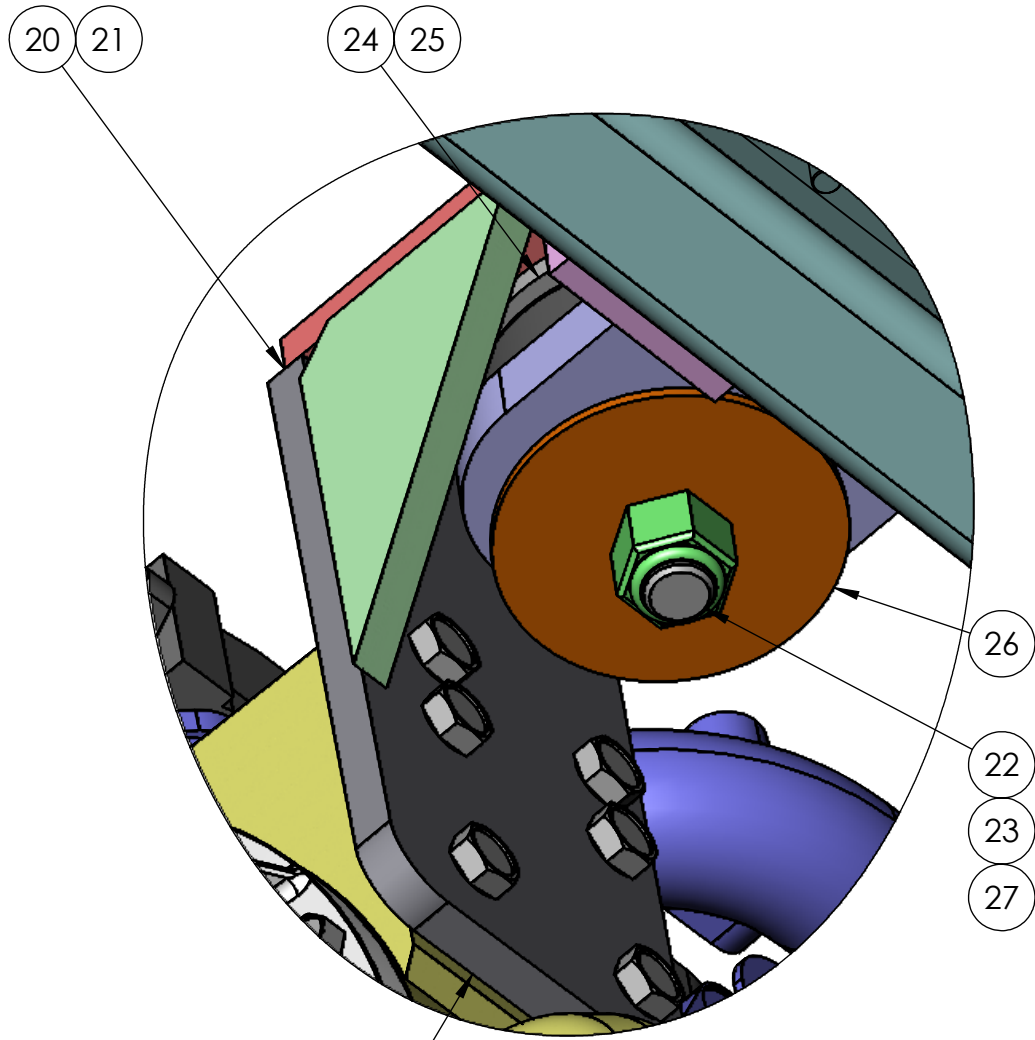

ENGINE MOUNT

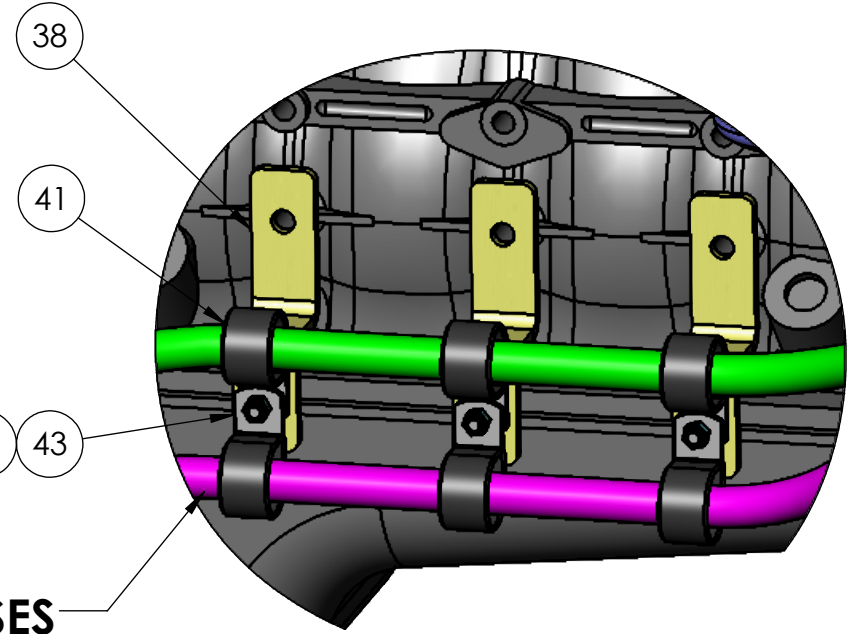

TRANSMISSION HOSES

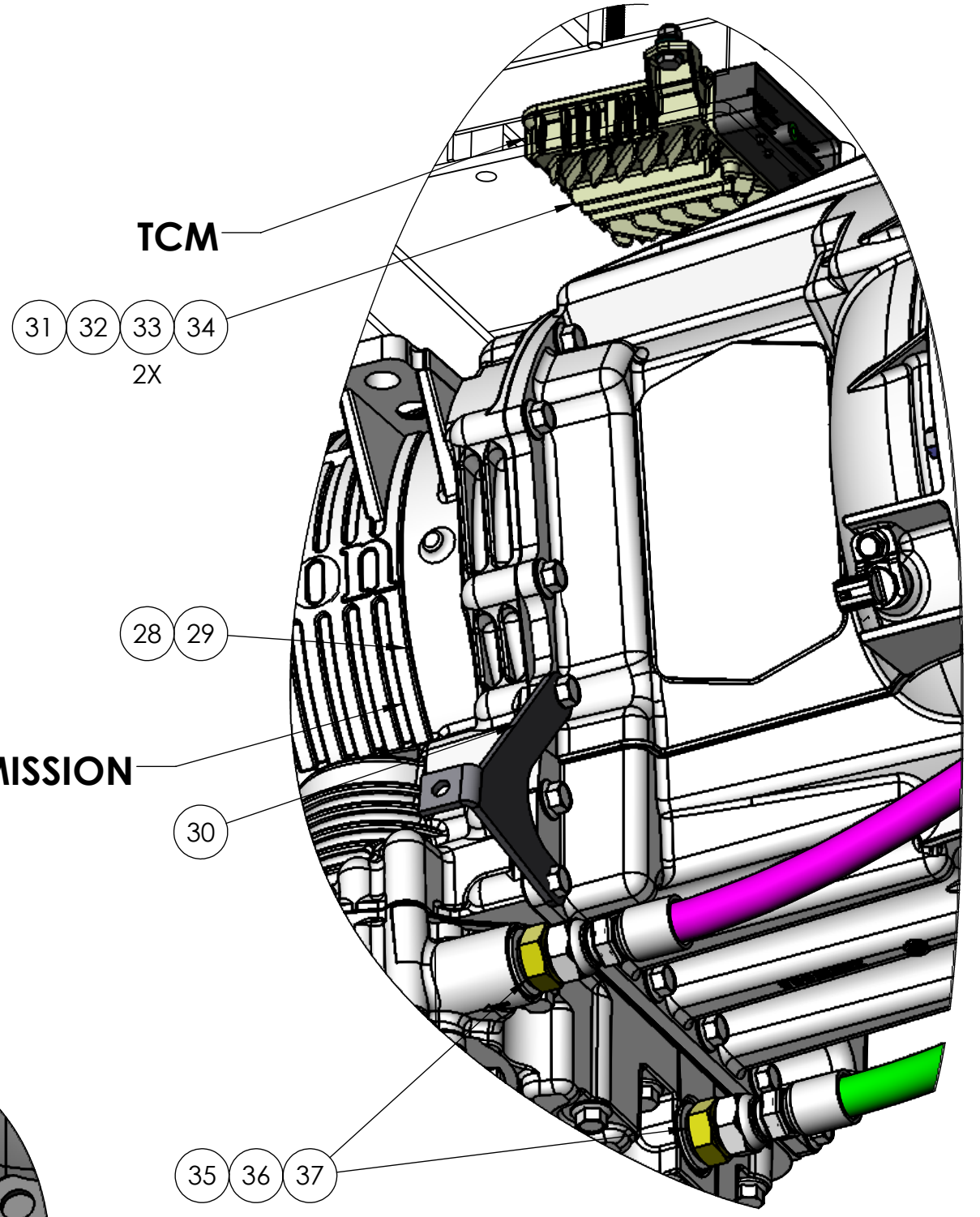

TRANSMISSION

TCM

DIMENSIONS ARE IN INCHES		NAME	DATE
TOLERANCES:		DRAWN	MPC 01/09/2018
DECIMAL:		CHECKED	---
X.X ± 0.06		APPROVED	---
X.XX ± 0.03		DO NOT SCALE DRAWING	
X.XXX ± 0.005		THE SUBJECT MATTER SHOWN AND DESCRIBED IN THIS DRAWING AND ANY OTHER INFORMATION ADVANCED IN CONNECTION THEREWITH, IS PROPRIETARY PROPERTY AND IS TO BE HELD IN STRICT CONFIDENCE BY YOU. ALL RIGHTS TO ANY INVENTIONS, DESIGNS, TRADE MARKS, TRADE NAMES AND COPYRIGHTS DISCLOSED ARE RESERVED TO TICO TERMINAL SERVICES, INC.	
ANGULAR:		INTERPRET GEOMETRIC TOLERANCING PER: ASME 14.5M-1994	
± 0.5°		MATERIAL	
FRACTIONAL ± 1/32"		N/A	
		FINISH	
		N/A	
		THICKNESS	
		N/A	

TICO  TICO/TERMINAL SERVICE
66 CYPRESS RIDGE DR.
RIDGELAND, SC 29936
(843) 717-2226

TITLE: ASSEMBLY, ENGINE & TRANSMISSION		
SIZE B	DWG. NO. 71838-E1	REV E
SCALE: 1:16	WEIGHT:	SHEET 3 OF 5

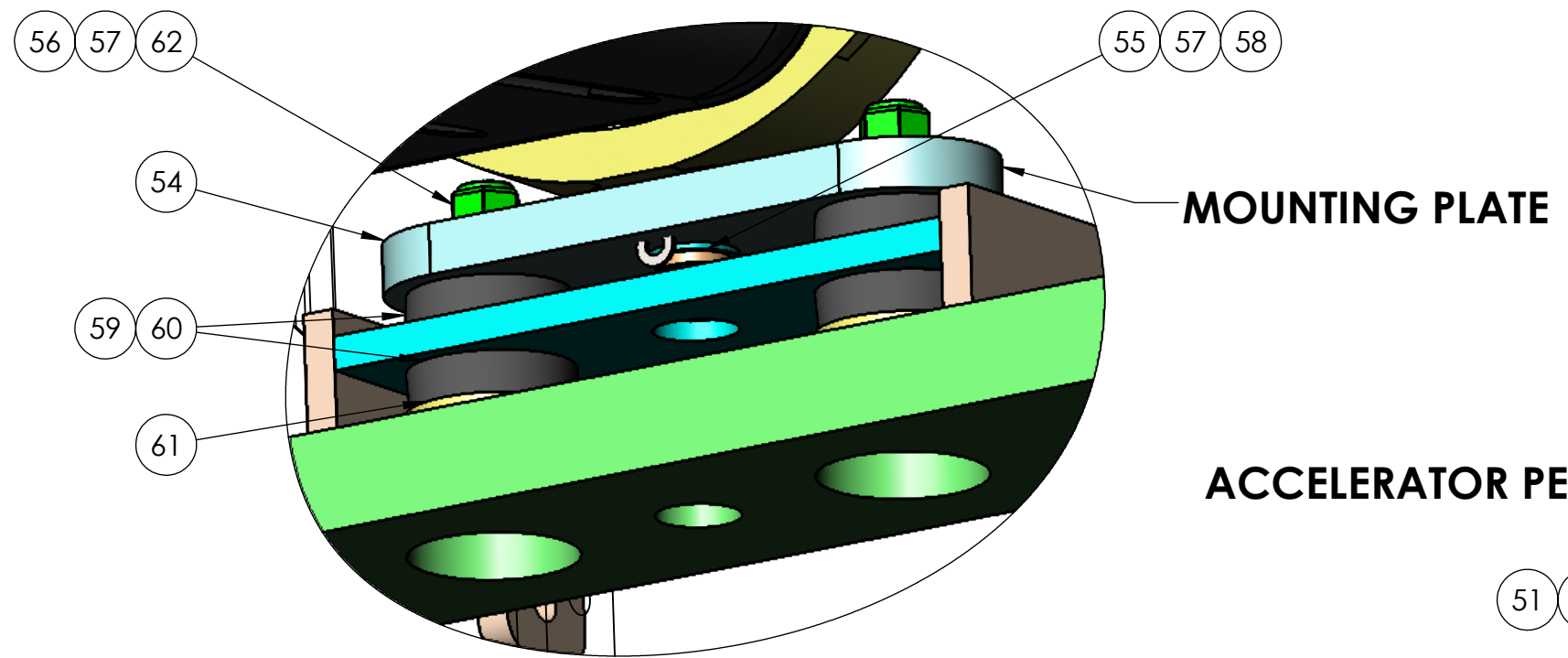

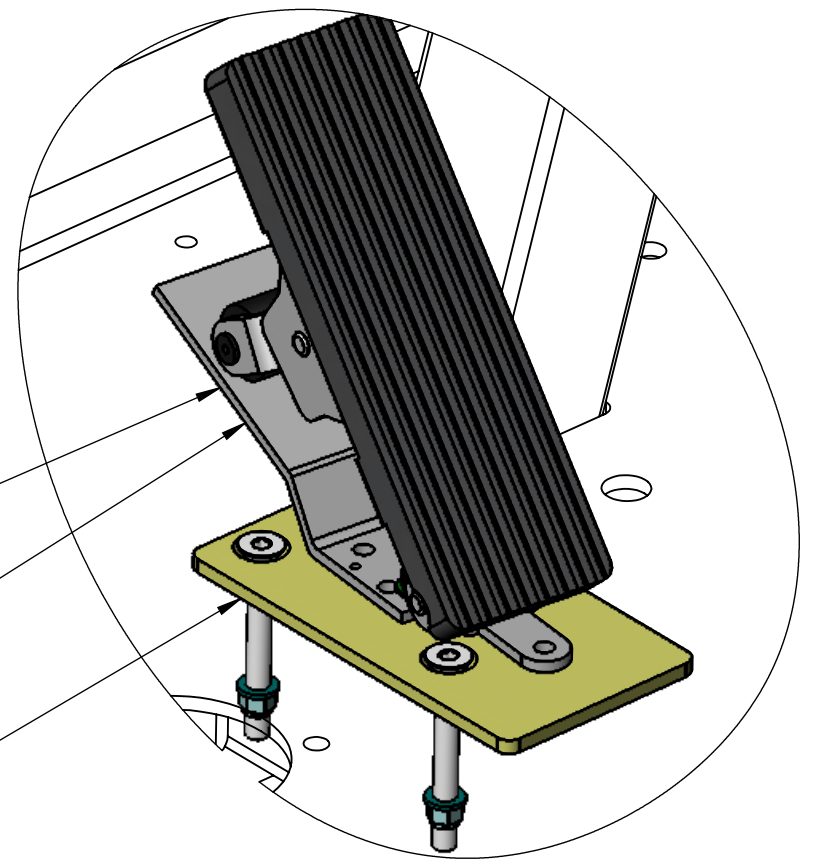

MOUNTING PLATE

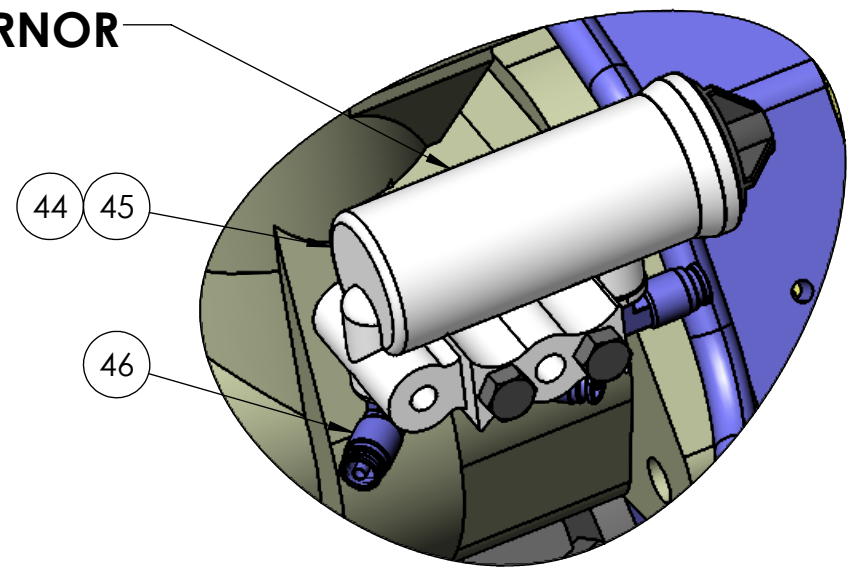

ACCELERATOR PEDAL

AIR GOVERNOR



DIMENSIONS ARE IN INCHES TOLERANCES: DECIMAL: X.X ± 0.06 X.XX ± 0.03 X.XXX ± 0.005 ANGULAR: ± 0.5° FRACTIONAL ± 1/32"	NAME	DATE	 TICO/TERMINAL SERVICE 66 CYPRESS RIDGE DR. RIDGELAND, SC 29936 (843) 717-2226	
	DRAWN	MPC		01/09/2018
	CHECKED	---		---
	APPROVED	---		---
INTERPRET GEOMETRIC TOLERANCING PER: ASME 14.5M-1994	DO NOT SCALE DRAWING		TITLE: ASSEMBLY, ENGINE & TRANSMISSION	
MATERIAL N/A	THE SUBJECT MATTER SHOWN AND DESCRIBED IN THIS DRAWING AND ANY OTHER INFORMATION ADVANCED IN CONNECTION THEREWITH, IS PROPRIETARY PROPERTY AND IS TO BE HELD IN STRICT CONFIDENCE BY YOU. ALL RIGHTS TO ANY INVENTIONS, DESIGNS, TRADE MARKS, TRADE NAMES AND COPYRIGHTS DISCLOSED ARE RESERVED TO TICO TERMINAL SERVICES, INC.		SIZE B	
FINISH N/A	DWG. NO. 71838-E1	REV E		
THICKNESS N/A	SCALE: 1:16	WEIGHT:	SHEET 4 OF 5	

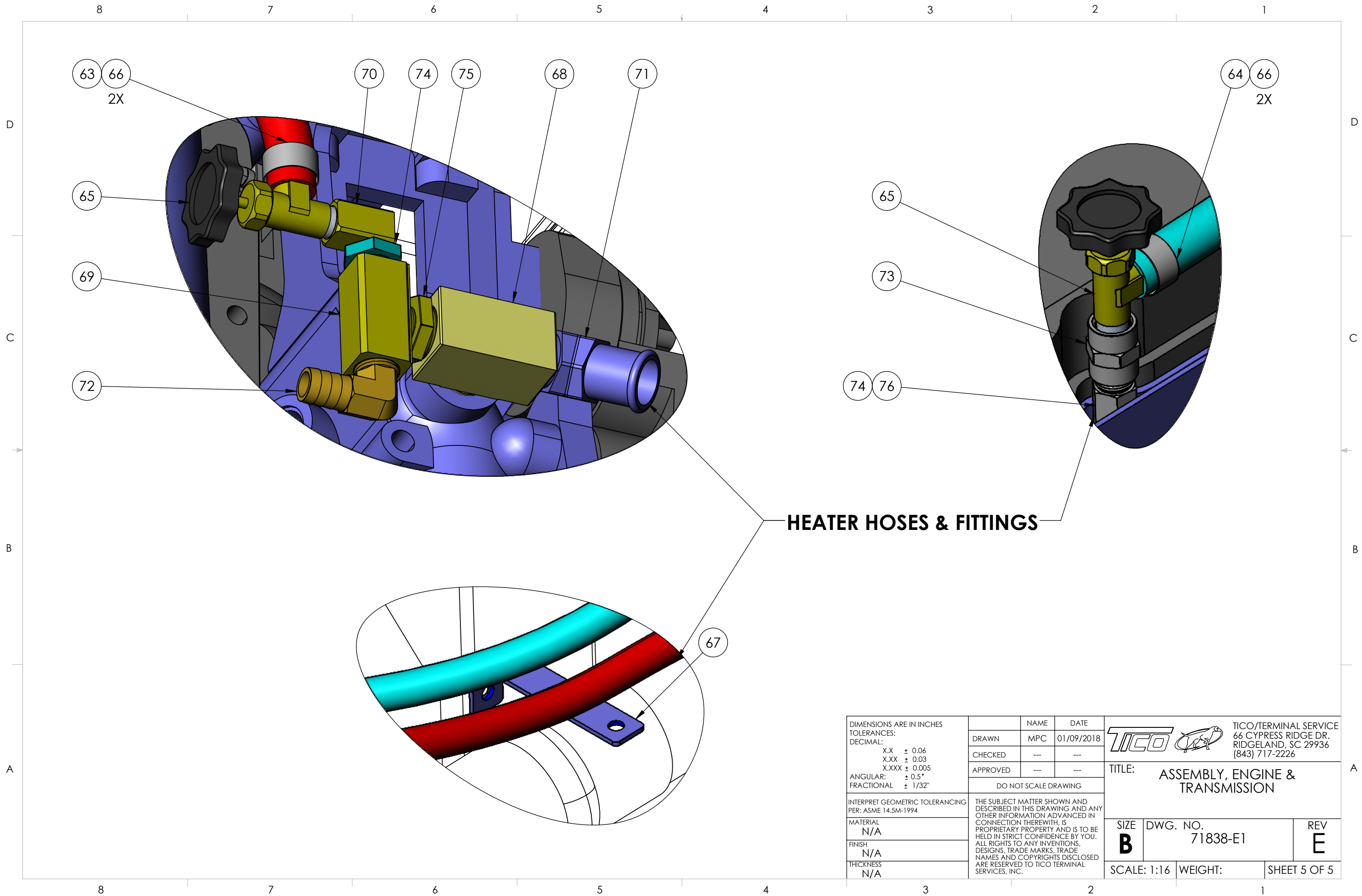

HEATER HOSES & FITTINGS

DIMENSIONS ARE IN INCHES TOLERANCES: DECIMAL: X.X ± 0.06 X.XX ± 0.03 X.XXX ± 0.005 ANGULAR: ± 0.5° FRACTIONAL ± 1/32"	NAME	DATE	 TICO/TERMINAL SERVICE 66 CYPRESS RIDGE DR. RIDGELAND, SC 29936 (843) 717-2226		
	DRAWN	MPC		01/09/2018	
	CHECKED	---		---	
	APPROVED	---		---	
INTERPRET GEOMETRIC TOLERANCING PER: ASME 14.5M-1994	DO NOT SCALE DRAWING		TITLE: ASSEMBLY, ENGINE & TRANSMISSION		
MATERIAL N/A	THE SUBJECT MATTER SHOWN AND DESCRIBED IN THIS DRAWING AND ANY OTHER INFORMATION ADVANCED IN CONNECTION THEREWITH, IS PROPRIETARY PROPERTY AND IS TO BE HELD IN STRICT CONFIDENCE BY YOU. ALL RIGHTS TO ANY INVENTIONS, DESIGNS, TRADE MARKS, TRADE NAMES AND COPYRIGHTS DISCLOSED ARE RESERVED TO TICO TERMINAL SERVICES, INC.		SIZE B		
FINISH N/A			DWG. NO. 71838-E1	REV E	
THICKNESS N/A			SCALE: 1:16	WEIGHT:	SHEET 5 OF 5

