

DETAIL B  
SCALE 1 : 5

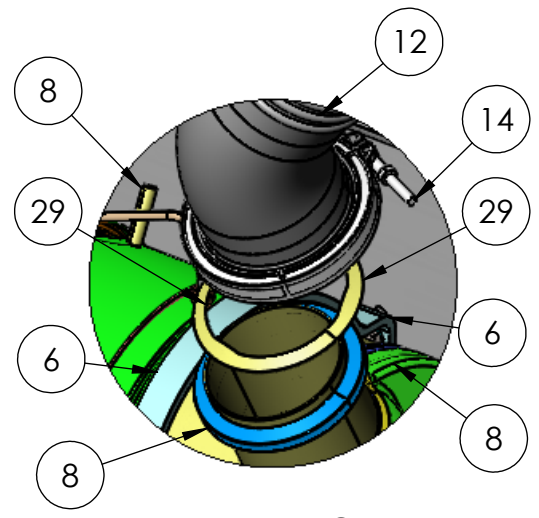

DETAIL C  
SCALE 1 : 5

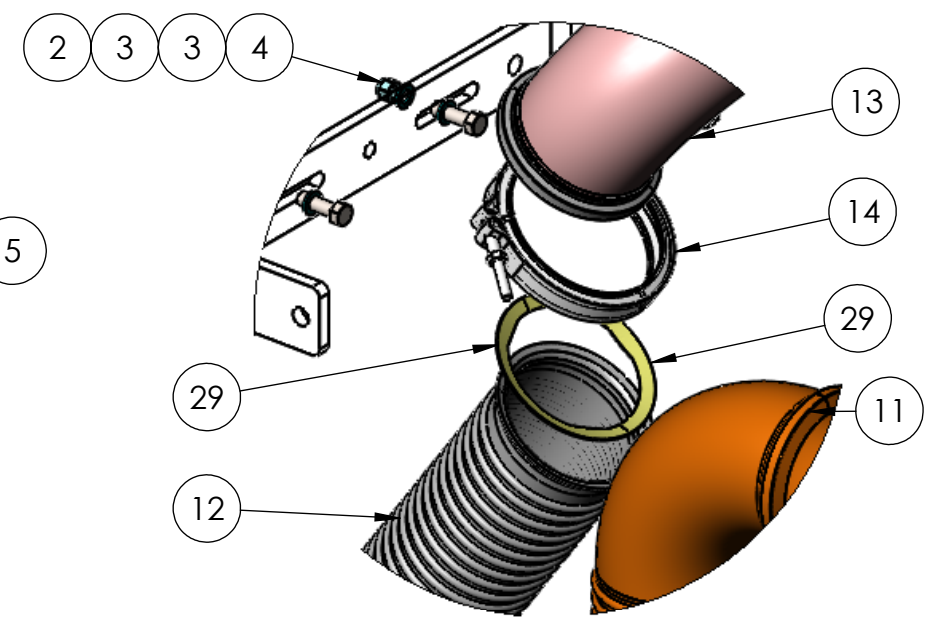

DETAIL D  
SCALE 1 : 5

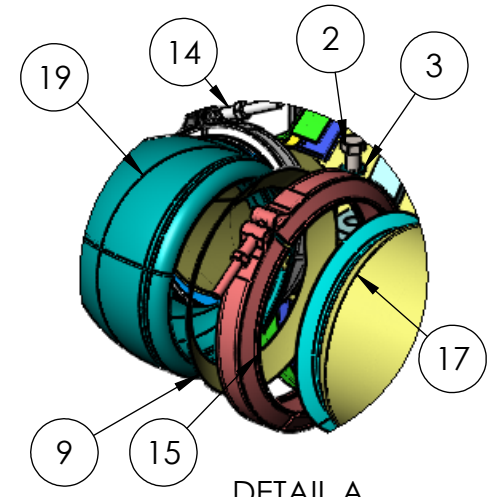

DETAIL A  
SCALE 1 : 5

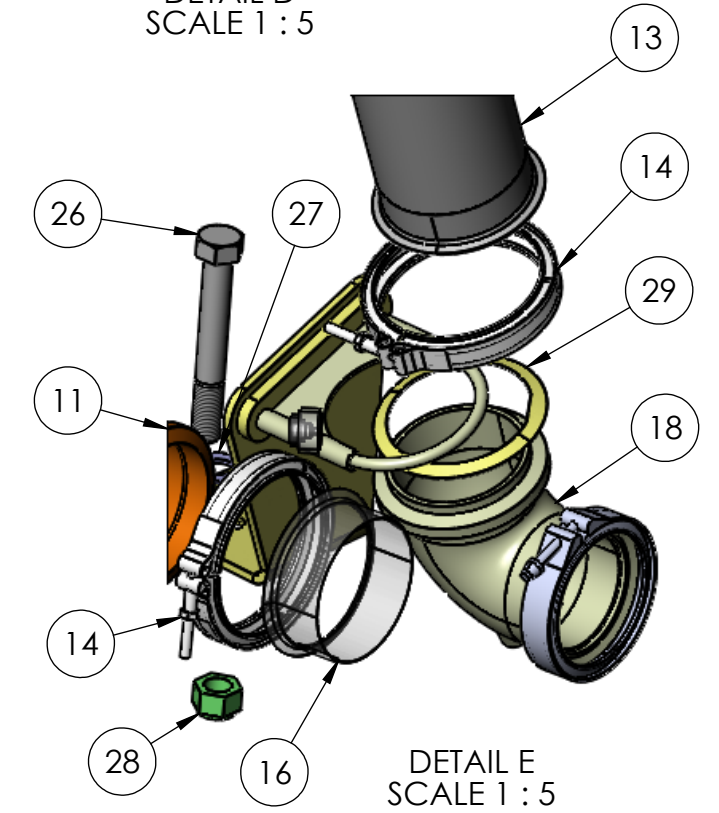
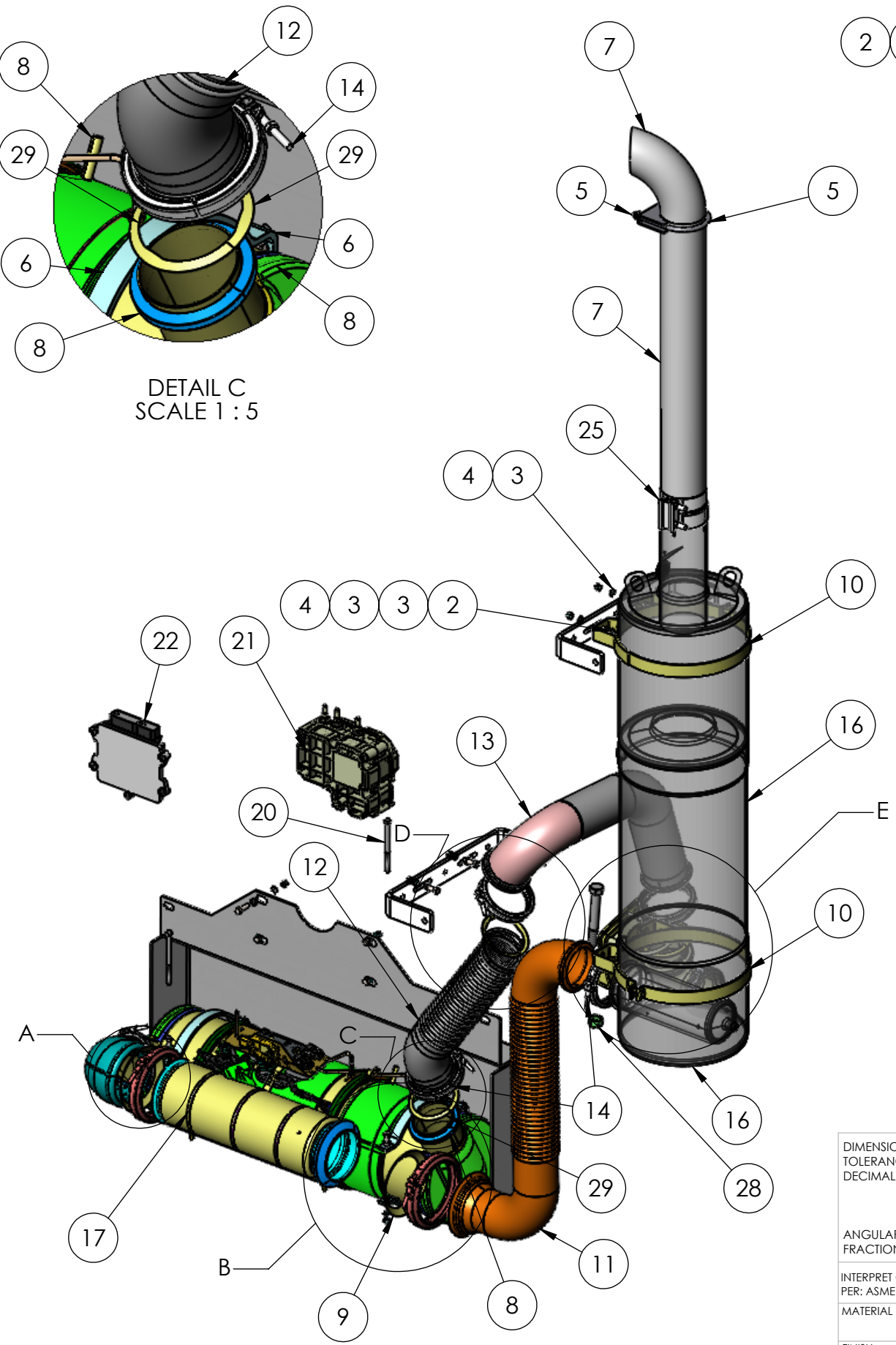

DETAIL E  
SCALE 1 : 5

DIMENSIONS ARE IN INCHES TOLERANCES: DECIMAL: X.X ± 0.06 X.XX ± 0.03 X.XXX ± 0.005 ANGULAR: ± 0.5° FRACTIONAL ± 1/32"	NAME DATE	TICO/TERMINAL SERVICE 66 CYPRESS RIDGE DR. RIDGELAND, SC 29936 (843) 717-2226	
	DRAWN CHECKED APPROVED		DF 08/12/2015
	DO NOT SCALE DRAWING		
	TITLE: EXHAUST SYSTEM - ISB10		
INTERPRET GEOMETRIC TOLERANCING PER: ASME 14.5M-1994	THE SUBJECT MATTER SHOWN AND DESCRIBED IN THIS DRAWING AND ANY OTHER INFORMATION ADVANCED IN CONNECTION THEREWITH, IS PROPRIETARY PROPERTY AND IS TO BE HELD IN STRICT CONFIDENCE BY YOU. ALL RIGHTS TO ANY INVENTIONS, DESIGNS, TRADE MARKS, TRADE NAMES AND COPYRIGHTS DISCLOSED ARE RESERVED TO TICO TERMINAL SERVICES, INC.		
MATERIAL FINISH THICKNESS	SIZE <b>B</b>	DWG. NO. 71771-E1	
	REV D1	SCALE: 1:12 SHEET 1 OF 1	

