

DIMENSIONS ARE IN INCHES TOLERANCES: DECIMAL: X.X ± 0.06 X.XX ± 0.03 X.XXX ± 0.005 ANGULAR: ± 0.5° FRACTIONAL ± 1/32"	NAME	DATE	 TICO MANUFACTURING 66 CYPRESS RIDGE DR. RIDGELAND, SC 29936 (843) 717-2226	
	DRAWN	MPC		09/21/2017
	CHECKED			
	APPROVED			
DO NOT SCALE DRAWING			TITLE: ASSEMBLY, HYDRAULIC SYSTEM	
MATERIAL	THE SUBJECT MATTER SHOWN AND DESCRIBED IN THIS DRAWING AND ANY OTHER INFORMATION ADVANCED IN CONNECTION THEREWITH, IS PROPRIETARY PROPERTY AND IS TO BE HELD IN STRICT CONFIDENCE BY YOU. ALL RIGHTS TO ANY INVENTIONS, DESIGNS, TRADE MARKS, TRADE NAMES AND COPYRIGHTS DISCLOSED ARE RESERVED TO TICO TERMINAL SERVICES, INC.		SIZE	
FINISH			DWG. NO.	REV
THICKNESS			B	71760-B1
SCALE: 1:11		WEIGHT:	SHEET 1 OF 4	

8 7 6 5 4 3 2 1

D
C
B
A

D
C
B
A

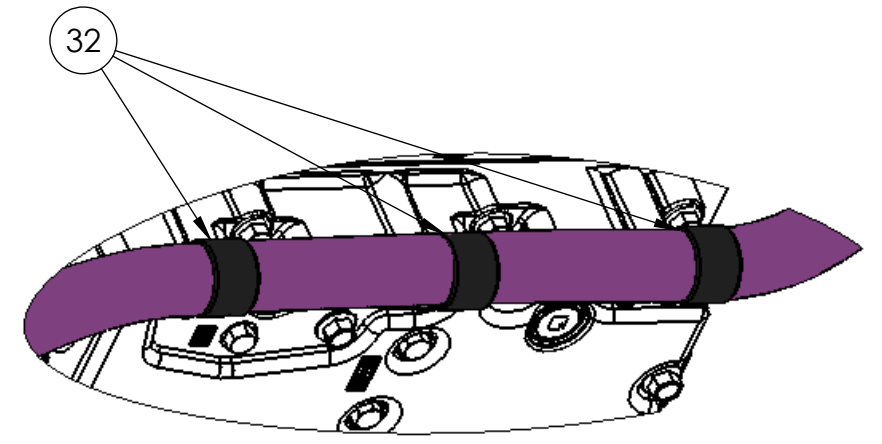
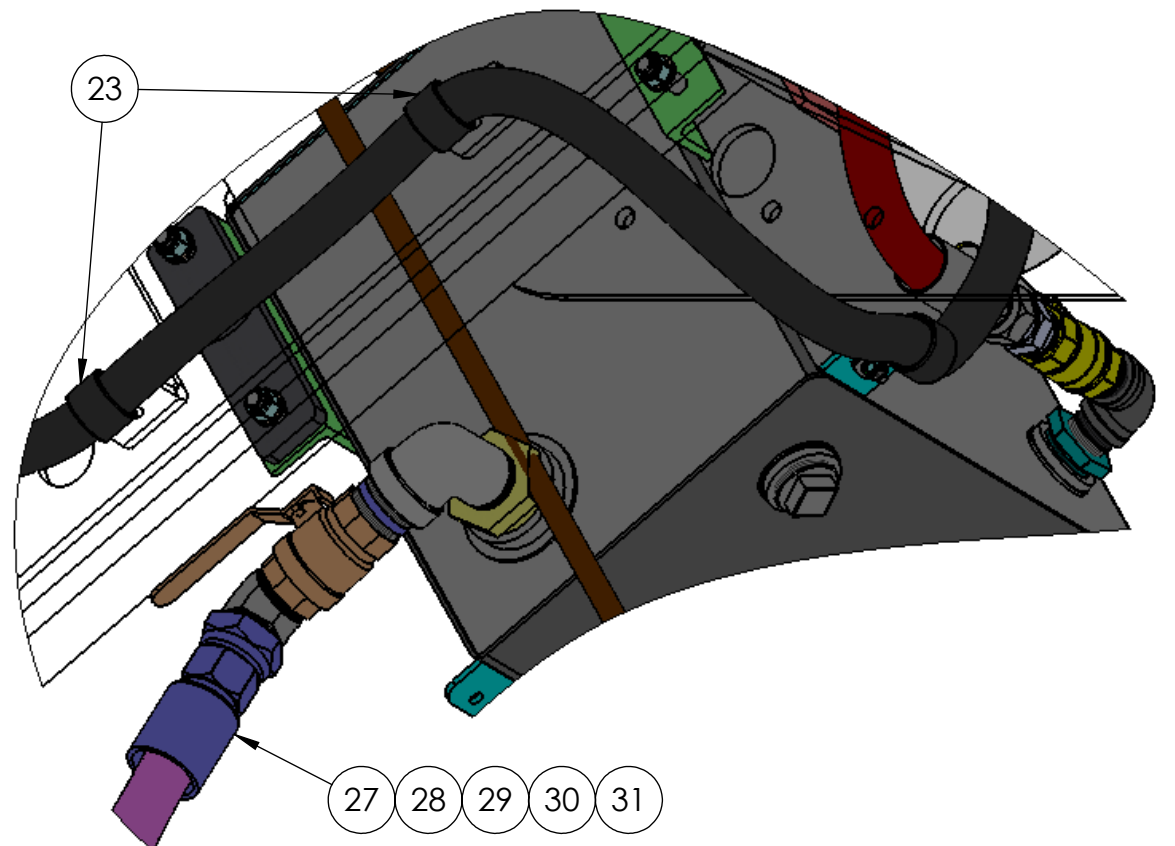
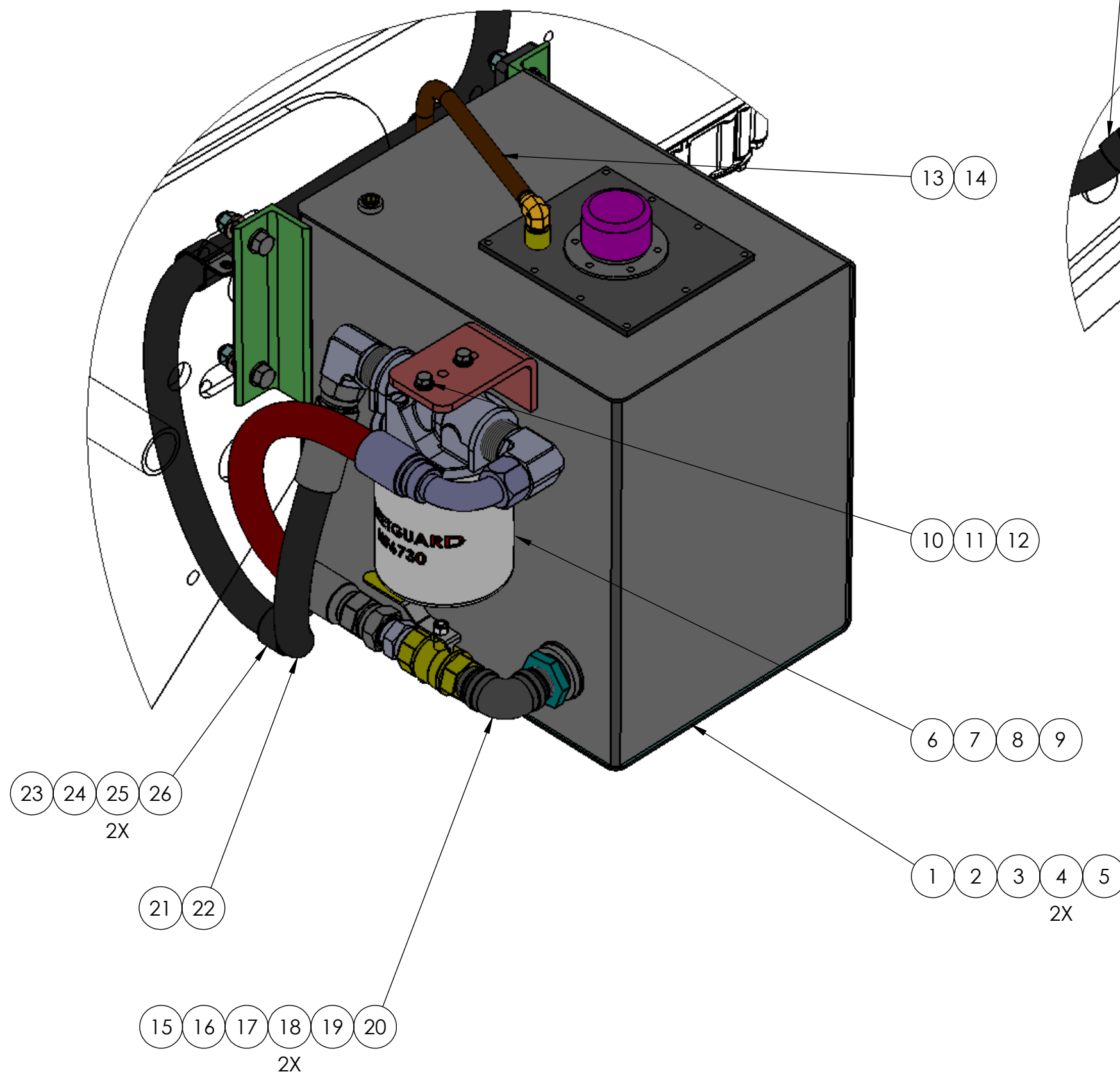

DIMENSIONS ARE IN INCHES TOLERANCES: DECIMAL: X.X ± 0.06 X.XX ± 0.03 X.XXX ± 0.005 ANGULAR: ± 0.5° FRACTIONAL ± 1/32"	DRAWN MPC	NAME MPC	DATE 09/21/2017	TICO/TERMINAL SERVICE 66 CYPRESS RIDGE DR. RIDGELAND, SC 29936 (843) 717-2226
	CHECKED			
	APPROVED			
	DO NOT SCALE DRAWING			
INTERPRET GEOMETRIC TOLERANCING PER: ASME 14.5M-1994	THE SUBJECT MATTER SHOWN AND DESCRIBED IN THIS DRAWING AND ANY OTHER INFORMATION ADVANCED IN CONNECTION THEREWITH, IS PROPRIETARY PROPERTY AND IS TO BE HELD IN STRICT CONFIDENCE BY YOU. ALL RIGHTS TO ANY INVENTIONS, DESIGNS, TRADE MARKS, TRADE NAMES AND COPYRIGHTS DISCLOSED ARE RESERVED TO TICO TERMINAL SERVICES, INC.			TITLE: ASSEMBLY, HYDRAULIC SYSTEM
MATERIAL	SIZE B	DWG. NO. 71760-B1	REV B	
FINISH	SCALE: 1:11	WEIGHT:	SHEET 2 OF 4	
THICKNESS				

8 7 6 5 4 3 2 1

8 7 6 5 4 3 2 1

D
C
B
A

D
C
B
A

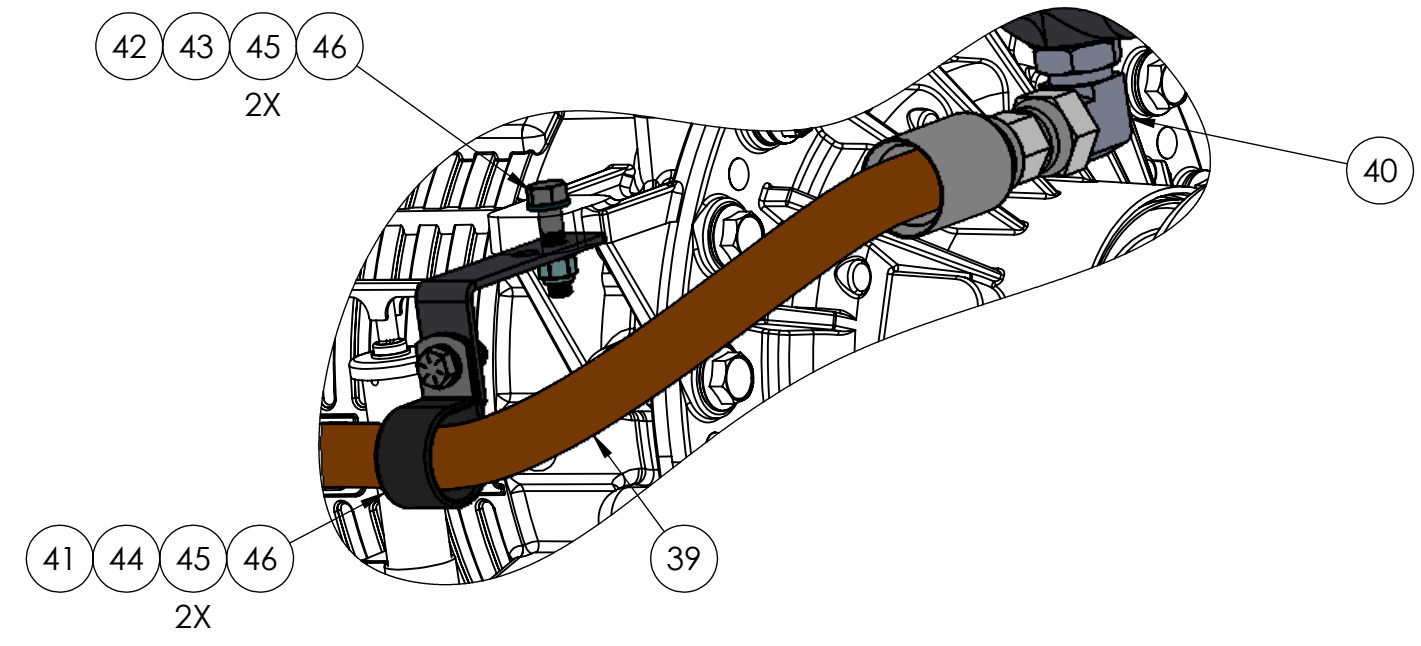
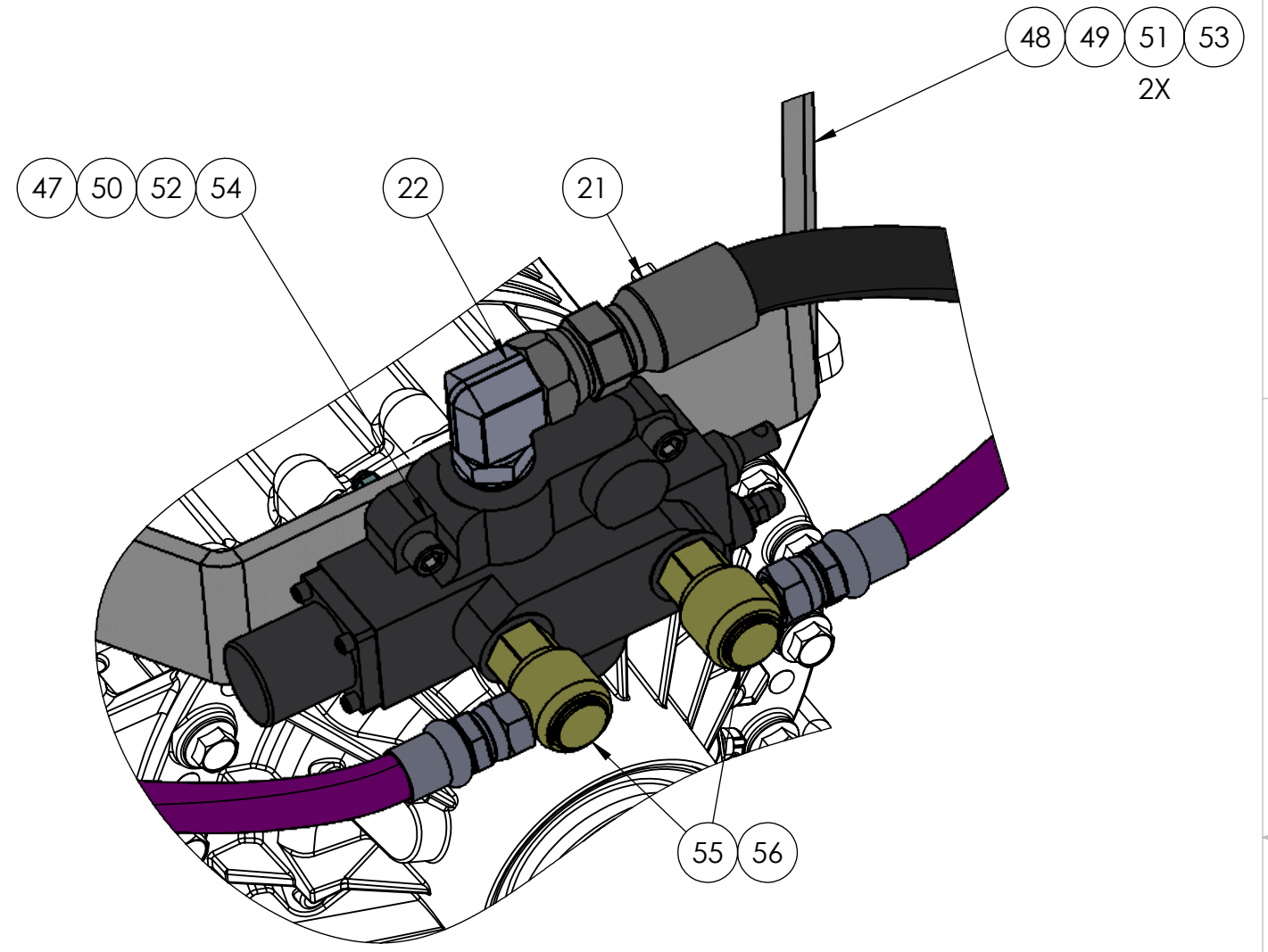
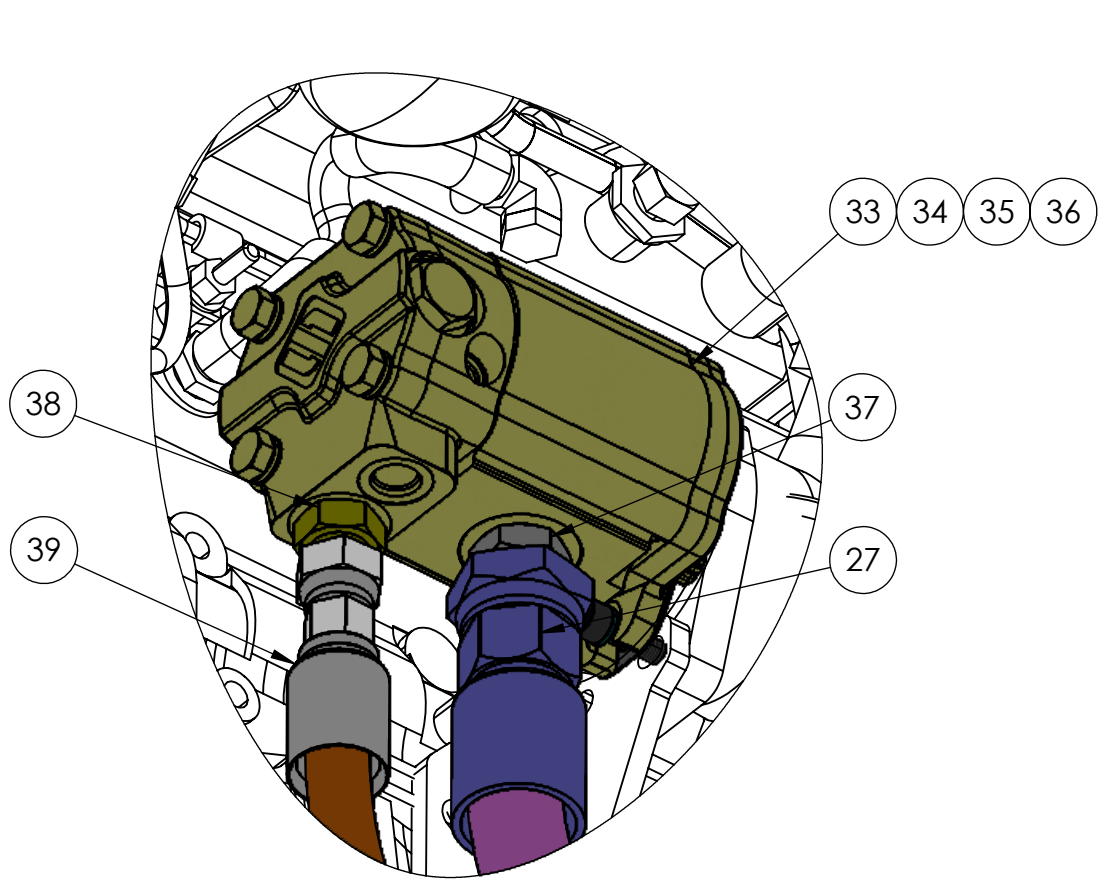

DIMENSIONS ARE IN INCHES TOLERANCES: DECIMAL: X.X ± 0.06 X.XX ± 0.03 X.XXX ± 0.005 ANGULAR: ± 0.5° FRACTIONAL ± 1/32"	DRAWN MPC	NAME MPC	DATE 09/21/2017	TICO/TERMINAL SERVICE 66 CYPRESS RIDGE DR. RIDGELAND, SC 29936 (843) 717-2226
	CHECKED			
	APPROVED			
	DO NOT SCALE DRAWING			
INTERPRET GEOMETRIC TOLERANCING PER: ASME 14.5M-1994	THE SUBJECT MATTER SHOWN AND DESCRIBED IN THIS DRAWING AND ANY OTHER INFORMATION ADVANCED IN CONNECTION THEREWITH, IS PROPRIETARY PROPERTY AND IS TO BE HELD IN STRICT CONFIDENCE BY YOU. ALL RIGHTS TO ANY INVENTIONS, DESIGNS, TRADE MARKS, TRADE NAMES AND COPYRIGHTS DISCLOSED ARE RESERVED TO TICO TERMINAL SERVICES, INC.			TITLE: ASSEMBLY, HYDRAULIC SYSTEM
MATERIAL	SIZE B	DWG. NO. 71760-B1	REV B	
FINISH	SCALE: 1:11	WEIGHT:	SHEET 3 OF 4	
THICKNESS				

8 7 6 5 4 3 2 1

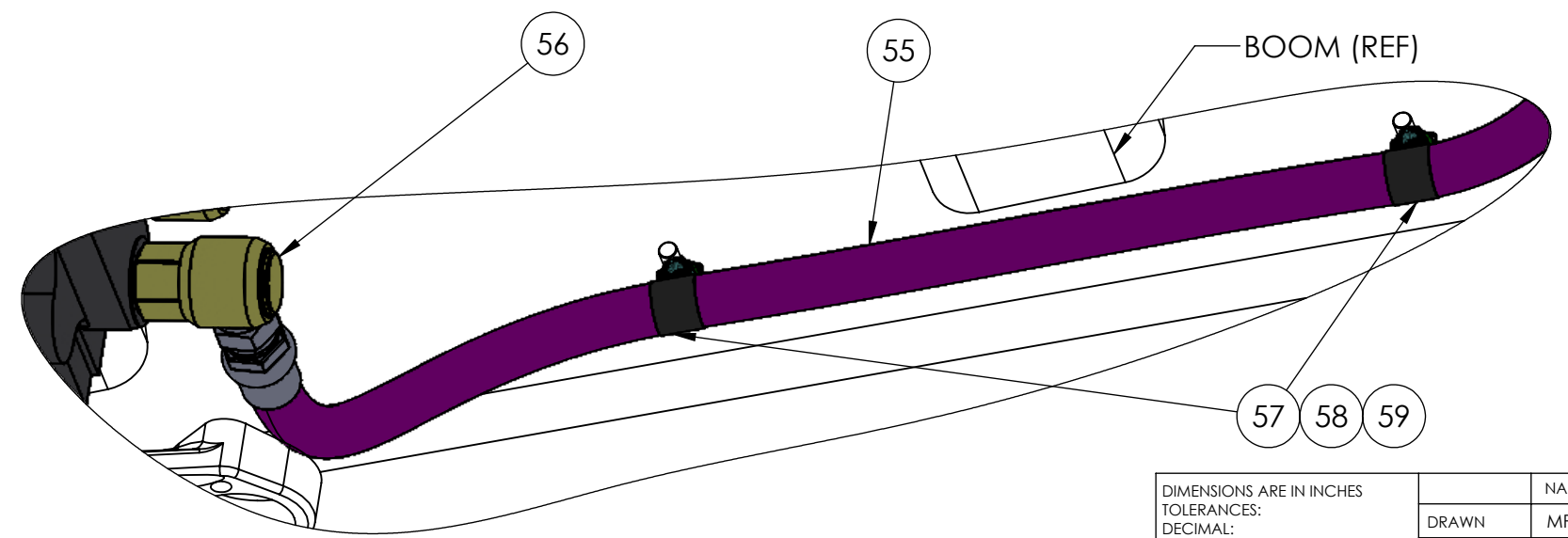
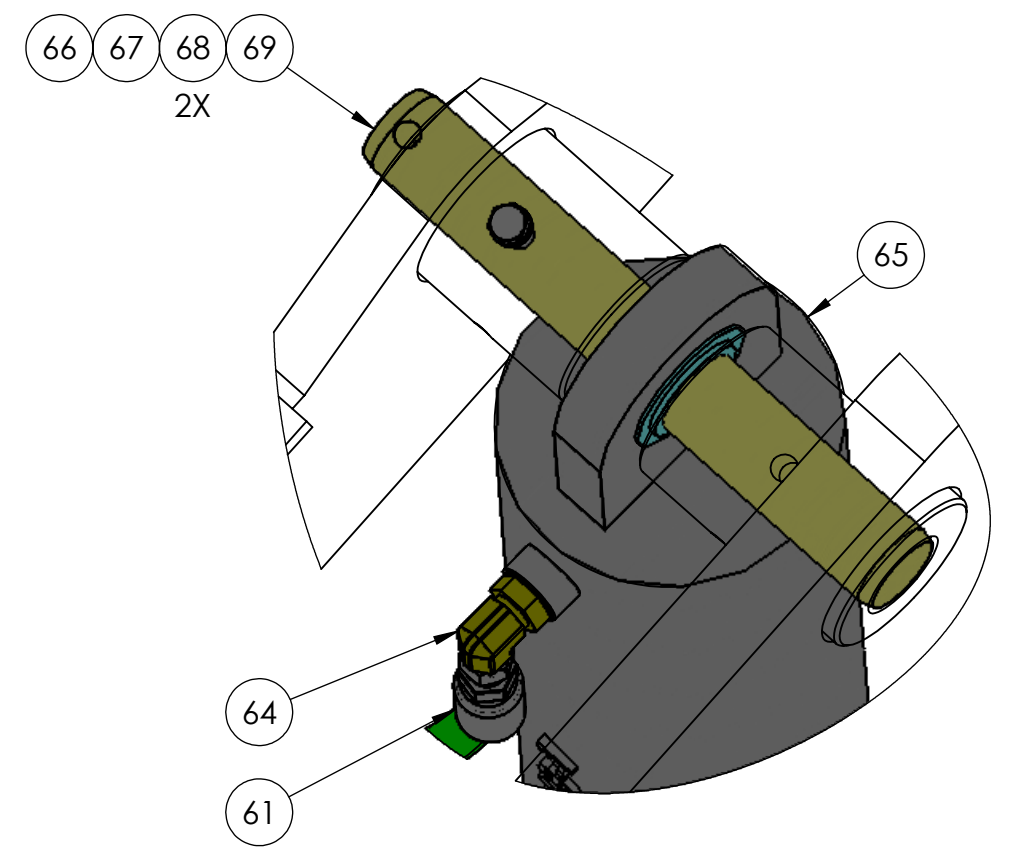
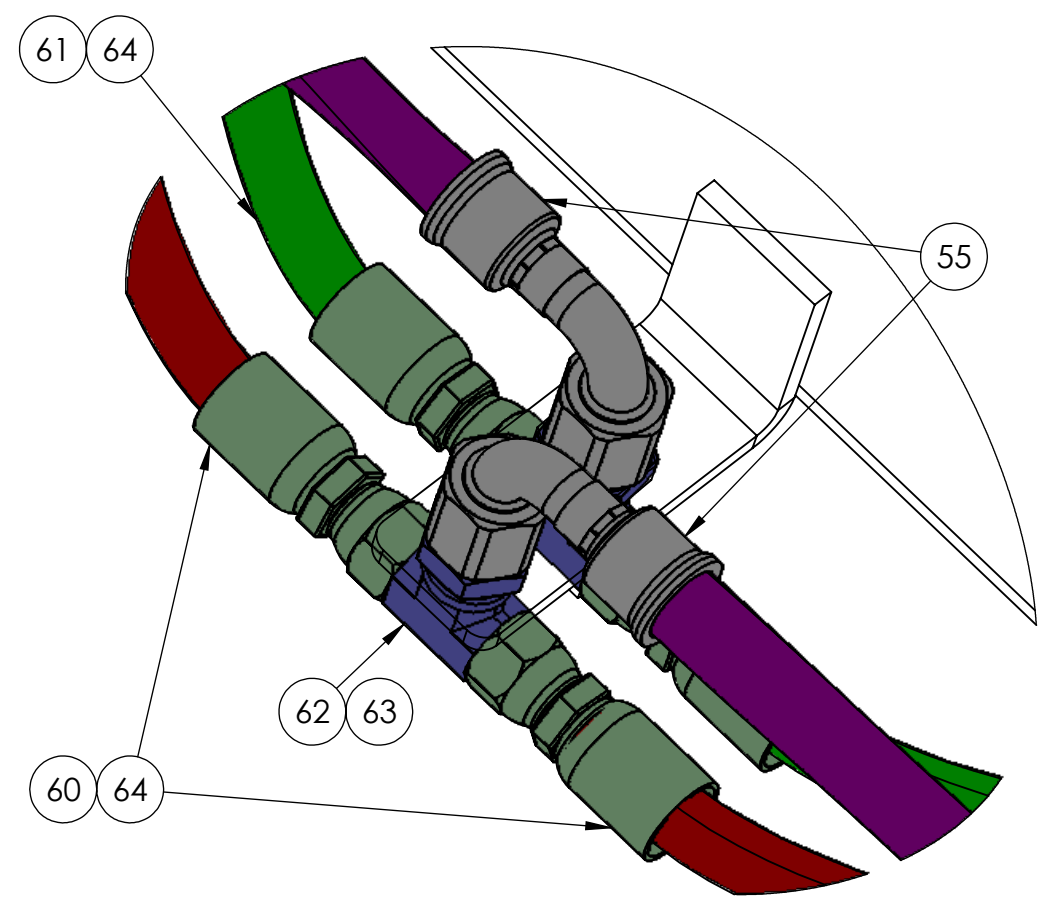

DIMENSIONS ARE IN INCHES TOLERANCES: DECIMAL: X.X ± 0.06 X.XX ± 0.03 X.XXX ± 0.005 ANGULAR: ± 0.5° FRACTIONAL ± 1/32"	DRAWN MPC	NAME MPC	DATE 09/21/2017	 TICO/TERMINAL SERVICE 66 CYPRESS RIDGE DR. RIDGELAND, SC 29936 (843) 717-2226
	CHECKED			
	APPROVED			
	DO NOT SCALE DRAWING			
INTERPRET GEOMETRIC TOLERANCING PER: ASME 14.5M-1994	THE SUBJECT MATTER SHOWN AND DESCRIBED IN THIS DRAWING AND ANY OTHER INFORMATION ADVANCED IN CONNECTION THEREWITH, IS PROPRIETARY PROPERTY AND IS TO BE HELD IN STRICT CONFIDENCE BY YOU. ALL RIGHTS TO ANY INVENTIONS, DESIGNS, TRADE MARKS, TRADE NAMES AND COPYRIGHTS DISCLOSED ARE RESERVED TO TICO TERMINAL SERVICES, INC.			TITLE: ASSEMBLY, HYDRAULIC SYSTEM
MATERIAL	SIZE B	DWG. NO. 71760-B1	REV B	
FINISH	SCALE: 1:11	WEIGHT:	SHEET 4 OF 4	
THICKNESS				

TICO PRO-SPOTTER					
			ASSEMBLY, HYDRAULIC SYSTEM	71760	
ITEM	PART #	QTY	DESCRIPTION	NOTE	
33	61962	1	PUMP, STEER PRIORITY, 20 GPM		
34	60212	1	GASKET		
35	80175	2	BOLT, SOCKET HEAD, M10 X 1.5 X 30 MM LONG		
36	85091	2	WASHER, FLAT, 3/8		
37	42019	1	FITTING, STRAIGHT, STEEL, 1" O-RING X 1-1/4 JIC (PUMP SUCTION)		
38	40471	1	FITTING, STRAIGHT, STEEL, 3/4 O-RING X 3/4 JIC (PUMP PRESSURE)		
39	41239	1	HOSE, 3/4 DIA X 77-5/8 OVERALL LENGTH (PUMP TO VALVE)		
40	10624	1	FITTING, ELBOW, 90°, 3/4 O-RING X 3/4 JIC (PRESSURE)		
41	40593	1	P-CLAMP, 1"		
42	61883	1	BRACKET, STANDOFF		
43	82394	1	BOLT, HEX HEAD, 3/8-16 X 1-1/2 LONG		
44	82372	1	BOLT, HEX HEAD, 3/8-16 X 1 LONG		
45	85091	4	WASHER, FLAT, 3/8		
46	85025	2	LOCKNUT, NYLON, 3/8-16		
47	60555-SB	1	VALVE, DIRECTIONAL CONTROL		
48	61758-3	1	MOUNT PLATE, CONTROL VALVE		
49	82429	2	BOLT, HEX HEAD, 1/2-13 X 2-1/4 LONG		
50	80171	2	CAPSCREW, SOCKET HEAD, 3/8-16 X 2 LONG		
51	85093	4	WASHER, FLAT, 1/2		
52	85091	2	WASHER, FLAT, 3/8		
53	85027	2	LOCKNUT, NYLON, 1/2-13		
54	85025	2	LOCKNUT, NYLON, 3/8-16		
55	41232	2	HOSE, 5/8 DIA X 45-1/8 LONG (VALVE TO TEE)		
56	41187	2	FITTING, ELBOW, 90°, SWIVEL, 3/4 ORB TO 5/8 JIC		
57	40596	4	P-CLAMP, 5/8"		
58	85090	4	WASHER, FLAT, 5/8		
59	85024	4	LOCKNUT, NYLON, 5/8-18		
60	41231	2	HOSE, HYDRAULIC, 1/2 ID X 27-15/16 LONG (RETRACT)		
61	41230	2	HOSE, HYDRAULIC, 1/2 ID X 24-15/16 LONG (EXTEND)		
62	50050	2	FITTING, BULKHEAD, BRANCH TEE, UNION, 5/8 JIC		
63	50050-2	2	JAM NUT, 7/8-14		
64	40460	4	FITTING, ELBOW, 90°, STEEL, 1/2 O-RING TO 1/2 JIC		
65	30148-1	2	CYLINDER, STROKE, 5" TO 15"		
66	30187-12	2	BOOM PIN, UPPER CYLINDER		
67	82493	2	BOLT, HEX HEAD, 3/8-16 X 2 LONG		
68	85091	4	WASHER, FLAT, 3/8		
69	85025	2	LOCKNUT, NYLON, 3/8-16		
REV	DATE	BY		SHEET	2
B	09/21/2017	MPC		OF	2

TICO MANUFACTURING - RIDGELAND, SC 29936